

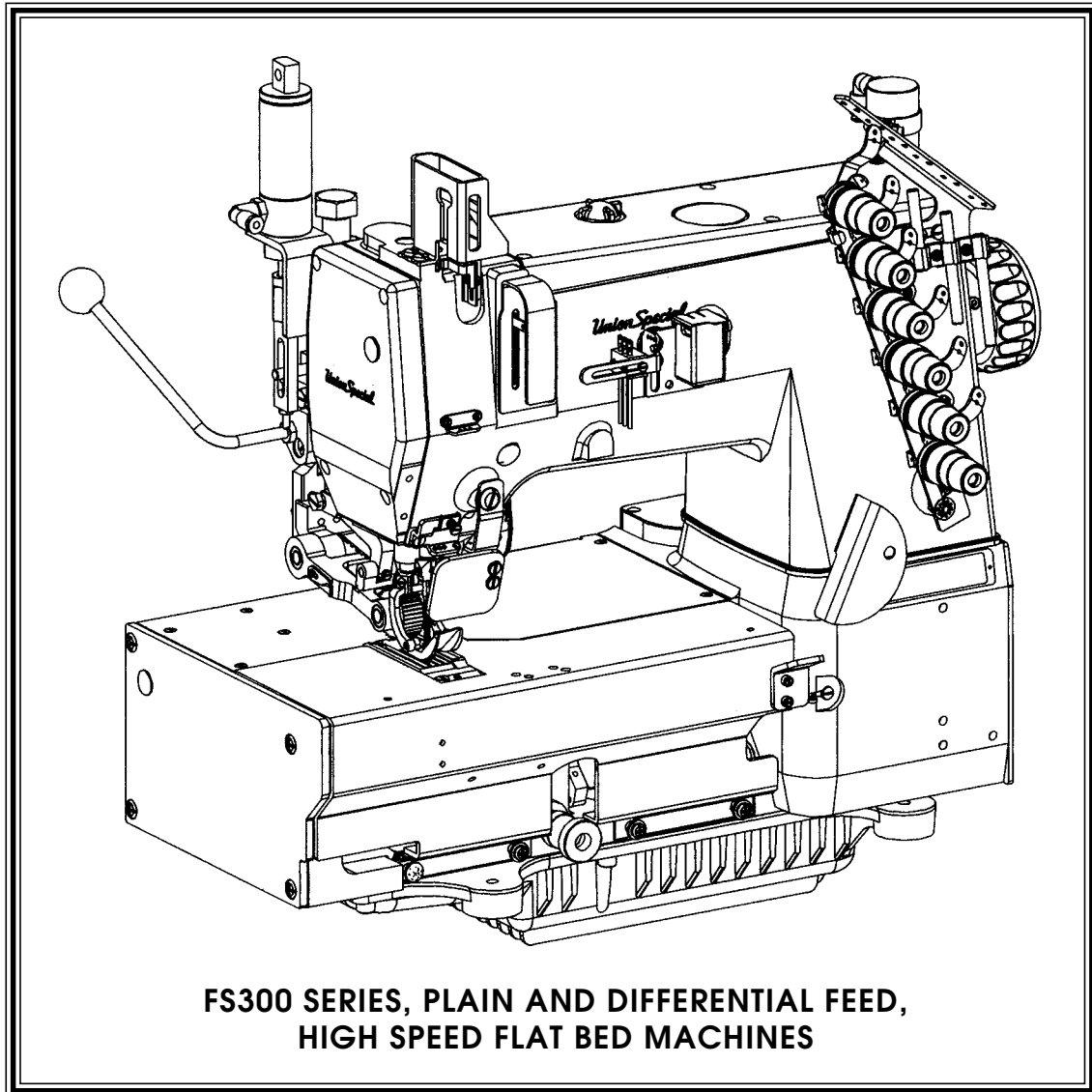

Union Special
Industrial Sewing Equipment

OPERATOR / ILLUSTRATED PARTS MANUAL



**MANUAL NO. PT9914
FOR STYLES
FS315L63
FS316L61
FS316L62
FS316L63**

Manual No. PT9914 Illustrated Parts List for FS300 Series Machines

First Edition Copyright 2000

By

Union Special Corporation Rights Reserved In All Countries

Printed in U.S.A. Jan. 2000

PREFACE

This parts manual has been prepared to assist you in locating individual parts or assemblies on FS300 Series machines. It can be used in conjunction with Union Special Engineer's Manual EN9424.

It is the desire of Union Special that each machine run at its optimum performance. Parts listed in this manual are designed specifically for your machine and are manufactured with utmost precision to assure long lasting service.

This manual has been comprised on the basis of available information. Changes in design and/or improvements may incorporate a slight modification of configuration in illustrations or part numbers.

On the following pages are illustrations and terminology used in describing the parts used on FS300 Series machines.

CONTENTS

PREFACE	2
IDENTIFICATION OF MACHINES	4
CLASS DESCRIPTION	4
STYLE OF MACHINES	4
STYLE OF MACHINES CONT.	5
ILLUSTRATIONS	5
IDENTIFYING PARTS	5
NEEDLES	5
SAFETY RULES	6
FS300 SERIES BUILDING BLOCK STYLE DESIGNATION SYSTEM	7
CAUTION AREAS:	8
OPERATOR'S DAILY CHECK LIST:	9
OPERATING CAUTIONS:	9
OPERATING CAUTIONS (CONT.):	10
OPERATING THE PEDALS:	10
LUBRICATION:	11
THREADING THE MACHINE:	12
THREADING THE MACHINE (CONT.):	13
THREADING METHODS	14
ADJUSTING THE STITCH LENGTH:	15
PRESSER FOOT PRESSURE AND LIFTER:	15
FEED, NEEDLE LOOPER TIMING:	16
NEEDLE ALIGNMENT:	16
LOOPER SETTING:	17
NEEDLE BAR SETTING:	17



REAR NEEDLE GUARD:	18
FEED DOG CENTERING AND HEIGHT ABOVE THROAT PLATE:	18
PRESSER FOOT:	18
LOOPER THREAD TAKE-UP CAM SETTING:	19
THREAD CONTROL:	19
PULLER ADJUSTMENTS:	20
PULLER ADJUSTMENTS CONT.:	21
BUSHINGS	23
NEEDLE BAR	25
UPPER MAIN SHAFT	27
THREAD GUIDE	29
TENSION RELEASE & THREAD TENSION	31
PRESSER FOOT LIFT	33
COVERS, UPPER ARM	35
LOWER MAIN SHAFT	37
LUBRICATION, OIL TUBING & OIL PUMP	39
LOOPER DRIVE	41
NEEDLE GUARD	43
LOOPER THREAD TAKE-UP	45
FEED DRIVE MECHANISM FOR PLAIN FEED	47
FEED DRIVE MECHANISM FOR DIFFERENTIAL FEED	49
FEED DRIVE MECHANISM FOR PLAIN FEED	51
FEED DRIVE MECHANISM FOR DIFFERENTIAL FEED	53
COVERS, LOWER BED	55
COVERS, LOWER BED	57
SEWING PARTS	59
FOLDERS	61
PULLER DRIVE ASSEMBLY	63
PULLER ASSEMBLY	65
PULLER ASSEMBLY	67
MISCELLANEOUS PARTS PA1 (USE WITH CC2 CHAIN CUTTER)	69
MISCELLANEOUS PARTS PA1A (USE WITHOUT CC2 CHAIN CUTTER)	71
TUBING PA1 WITH CHAIN CUTTER	72
TUBING PA1A WITHOUT CHAIN CUTTER	73
TABLING (EXTRA SEND CHARGE)	75
PRESSER FOOT LIFTER	77
ACCESSORIES	79
NUMERICAL INDEX OF PARTS	80
NUMERICAL INDEX OF PARTS	81



IDENTIFICATION OF MACHINES

Each UNION SPECIAL machine is identified by a style number, which is stamped into the style plate affixed to the middle of the machine under the tension assembly. The serial number is stamped into the serial number plate affixed to the right rear base of the machine.

CLASS DESCRIPTION

Precision high speed, single needle, plain or differential feed flat bed machines. Totally enclosed feed and looper drive mechanism, automatic forced feed lubrication system with easily replaceable filter. Main feed has thumbscrew adjustment and differential feed has lever adjustment and independently driven rear needle guard.

STYLE OF MACHINES

FS316L61-3H36CC2PA1	DOUBLE LAP SEAM. Three needle, plain feed, high capacity, flat sewing parts, close-coupled toothed roller puller, pneumatic power "AIR-KLIPP" Chain cutter, pneumatic assisted presser foot and roller lift, and double lap seam folder with 1/8" (3.2mm) capacity. For attaching the risers to jeans, seat seaming operations on jeans, bibs to overalls and piecing sleeves on denim jackets. Seam Specifications 401LSc-3. Recommended needle 128 GAS sizes 140/054 - Stitch range 7-10 S.P.I.. Maximum recommended speed 6000 R.P.M.
FS316L61-3H36PA1	DOUBLE LAP SEAM. Three needle, plain feed, high capacity, flat sewing parts, close-coupled toothed roller puller, pneumatic assisted presser foot and roller lift, and double lap seam folder with 1/8" (3.2mm) capacity. For attaching the risers to jeans, seat seaming operations on jeans, bibs to overalls and piecing sleeves on denim jackets. Seam Specifications 401LSc-3. Recommended needle 128 GAS sizes 140/054 - Stitch range 7-10 S.P.I.. Maximum recommended speed 6000 R.P.M..
FS316L62-3H36CC2PA1	DOUBLE LAP SEAM. Three needle, plain feed, high capacity, .040" stepped chaining sewing parts, close-coupled toothed roller puller, pneumatic power "AIR-KLIPP" Chain cutter, pneumatic assisted presser foot and roller lift, and double lap seam folder with 1/8" (3.2mm) capacity. For attaching the risers to jeans, seat seaming operations on jeans, bibs to overalls and piecing sleeves on denim jackets. Seam Specifications 401LSc-3. Recommended needle 128 GAS sizes 140/054 - Stitch range 7-10 S.P.I.. Maximum recommended speed 6000 R.P.M..
FS316L62-3H36PA1	DOUBLE LAP SEAM. Three needle, plain feed, high capacity, .040" stepped chaining sewing parts, close-coupled toothed roller puller, pneumatic assisted presser foot and roller lift, and double lap seam folder with 1/8" (3.2mm) capacity. For attaching the risers to jeans, seat seaming operations on jeans, bibs to overalls and piecing sleeves on denim jackets. Seam Specifications 401LSc-3. Recommended needle 128 GAS sizes 140/054 - Stitch range 7-10 S.P.I.. Maximum recommended speed 6000 R.P.M..
FS316L63-3H32CC2PA1	DOUBLE LAP SEAM. Three needle, plain feed, high capacity, .070" stepped chaining sewing parts, close-coupled toothed roller puller, pneumatic power "AIR-KLIPP" Chain cutter, pneumatic assisted presser foot and roller lift, and double lap seam folder with 1/8" (3.2mm) capacity. For attaching the risers to jeans, seat seaming operations on jeans, bibs to overalls and piecing sleeves on denim jackets. Seam Specifications 401LSc-3. Recommended needle 128 GAS sizes 140/054 - Stitch range 7-10 S.P.I.. Maximum recommended speed 6000 R.P.M..
FS316L63-3H32PA1	DOUBLE LAP SEAM. Three needle, plain feed, high capacity, .070" stepped chaining sewing parts, close-coupled toothed roller puller, pneumatic assisted presser foot and roller lift, and double lap seam folder with 1/8" (3.2mm) capacity. For attaching the risers to jeans, seat seaming operations on jeans, bibs to overalls and piecing sleeves on denim jackets. Seam Specifications 401LSc-3. Recommended needle 128 GAS sizes 140/054 - Stitch range 7-10 S.P.I.. Maximum recommended speed 6000 R.P.M..



STYLE OF MACHINES CONT.

FS315L63-3H32CC2PA1 Same as FS316L63-3H32CC2PA1 except differential feed.

FS315L63-3H32PA1 Same as FS316L63-3H32PA1 except differential feed.

ILLUSTRATIONS

This manual has been arranged to simplify ordering repair parts. Exploded views of various sections of the mechanism are shown so that the parts may be seen in their actual position in the machine. On the page opposite the illustration will be found a listing of the parts with their part numbers, description and the number of pieces required in the particular view being shown.

Numbers in the first column are reference numbers only, and merely indicate the position of the part in the illustration. The reference number should never be used in ordering parts. Always use the part number listed in the second column.

Component parts of sub-assemblies which can be furnished for repairs are indicated by indenting their descriptions under the description of the main sub-assembly. As an example refer to the following text.

5.	50366B	Needle Thread Strike-Off Assembly	1
6.	50358V	Needle Thread Strike-Off	1
7.	50370F	Thread Strike-Off Component	1
8.	SS7060310SP	Screw, for plate strike-off	1

When a part is common to all machines covered in this manual, no specific usage will be mentioned in the description. However, when the parts for the various machines are not the same, the specific usage will be mentioned in the description and, if necessary, the difference will be shown in the illustration.

*Ref. No. showing no Part No. is for location only. Part is not for sale separately.

A numerical index of all the parts shown in this manual is located at the back. This will facilitate locating the illustration and description when only a part number is known.

IDENTIFYING PARTS

Where construction permits, each part is stamped with its part number. On some of the smaller parts and on those where construction does not permit, an identification letter is stamped in to distinguish the part from similar ones.

PLEASE NOTE: Part numbers represent the same part, regardless of which manual they appear. On all orders please include part number, name and style of machine for which the part was ordered.

For optimum performance use only genuine Union Special replacement parts.

NEEDLES

Each needle has both a type and size number. The type number denotes the kind of shank, point, length, groove, finish and other details. The size number, stamped on the needle shank, denotes the largest diameter of the blade measured between the shank and the eye. Collectively, the type number and size number represent the complete symbol which is given on the label of all needles packed and sold by Union Special.

TYPE

DESCRIPTION

128 GAS	Short, double groove, struck groove, ball eye, spotted, round point, chromium plated- Sizes available 080/032, 090/036, 100/040, 110/044, 125/049, 150/060.
---------	---

When changing the needle, make sure it is fully inserted in the needle holder before the screw is tightened.

When ordering needles, please use the complete type and size numbers as printed on the package to ensure prompt and accurate processing of your order. A complete order should read as follows: "100 needles, type 128 GAS, size 150/060".



SAFETY RULES

1. Before putting the machines described in this manual into service, carefully read the instructions. The starting of each machine is only permitted after taking notice of the instructions and by qualified operators.

IMPORTANT! Before putting the machine into service, also read the safety rules and instructions from the motor supplier.

2. Observe the national safety rules valid for your country.
3. The sewing machines described in this instruction manual are prohibited from being put into service until it has been ascertained that the sewing units which these sewing machines will be built into, have conformed with the EC Council Directives (89/392/EEC, Annex II B).

Each machine is only allowed to be used as foreseen. The foreseen use of the particular machine is described in paragraph "STYLES OF MACHINES" of this instruction manual. Another use, going beyond the description, is not as foreseen.

4. All safety devices must be in position when the machine is ready for work or in operation. Operation of the machine without the appertaining safety devices is prohibited.
5. Wear safety glasses.
6. In case of machine conversions and changes all valid safety rules must be considered. Conversions and changes are made at your own risk.
7. The warning hints in the instructions are marked with one of these two symbols:

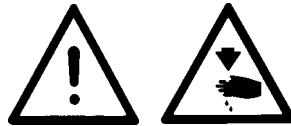

8. When doing the following the machine has to be disconnected from the power supply by turning off the main switch or by pulling out the main plug:
 - 8.1 When threading needle(s), looper, spreader etc.
 - 8.2 When replacing any parts such as needle(s), presser foot, throat plate, looper, spreader, feed dog, needle guard, folder, fabric guide etc.
 - 8.3 When leaving the workplace and when the workplace is unattended.
 - 8.4 When doing maintenance work.
 - 8.5 When using clutch motors without actuation lock, wait until the motor is stopped totally.
9. Maintenance, repair and conversion work (see item 8) must be done only by trained technicians or special skilled personnel under consideration of the instructions.
10. Any work on the electrical equipment must be done by an electrician or under direction and supervision of special skilled personnel.
11. Work on parts and equipment under electrical power is not permitted. Permissible exceptions are described in the applicable sections of standard sheet DIN VDE 0105.
12. Before doing maintenance and repair work on the pneumatic equipment, the machine has to be disconnected from the compressed air supply. In case of existing residual air pressure, after disconnecting from compressed air supply (i.e. pneumatic equipment with air tank), the pressure has to be removed by bleeding.

FS300 SERIES BUILDING BLOCK STYLE DESIGNATION SYSTEM

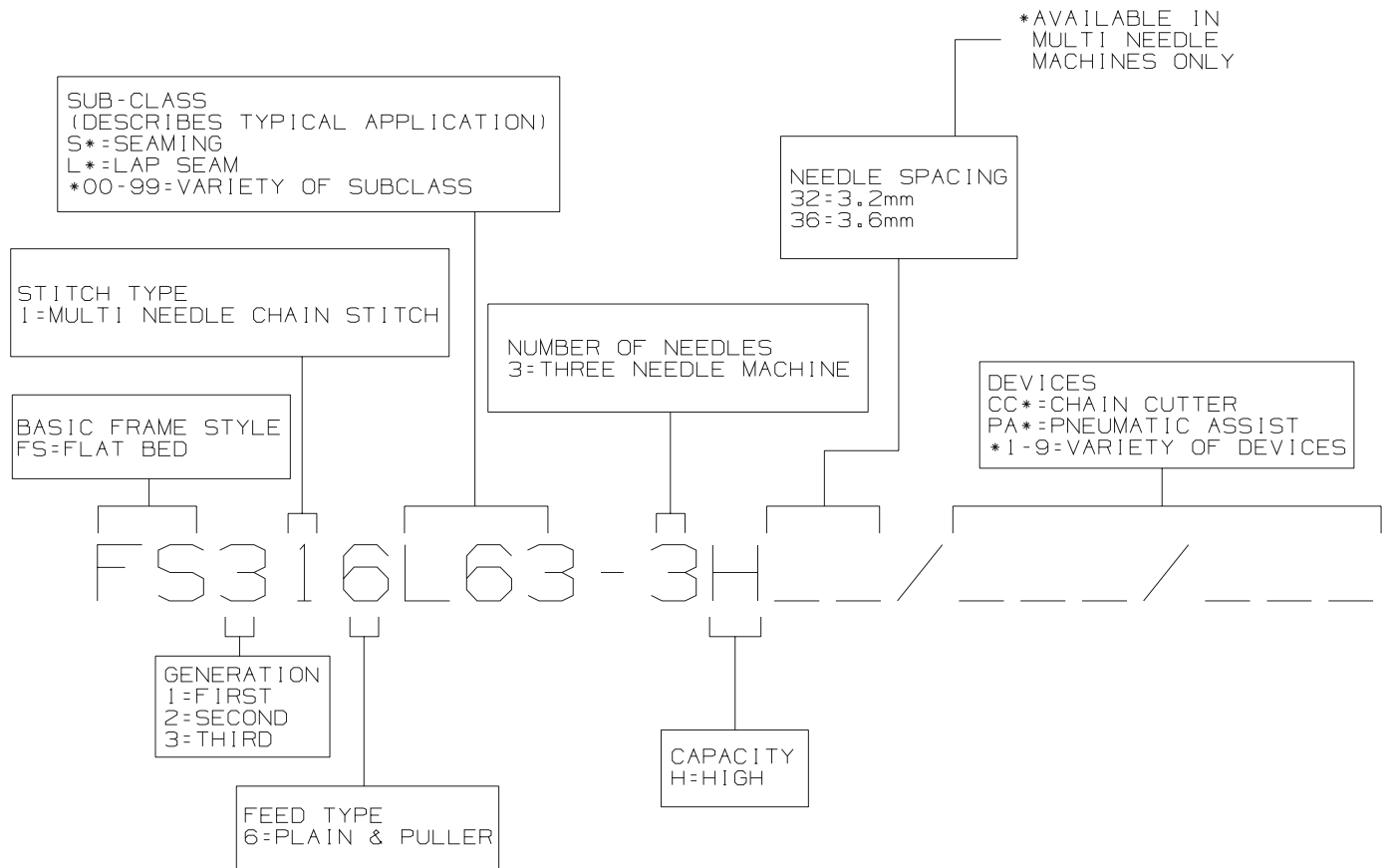

CAUTION AREAS:

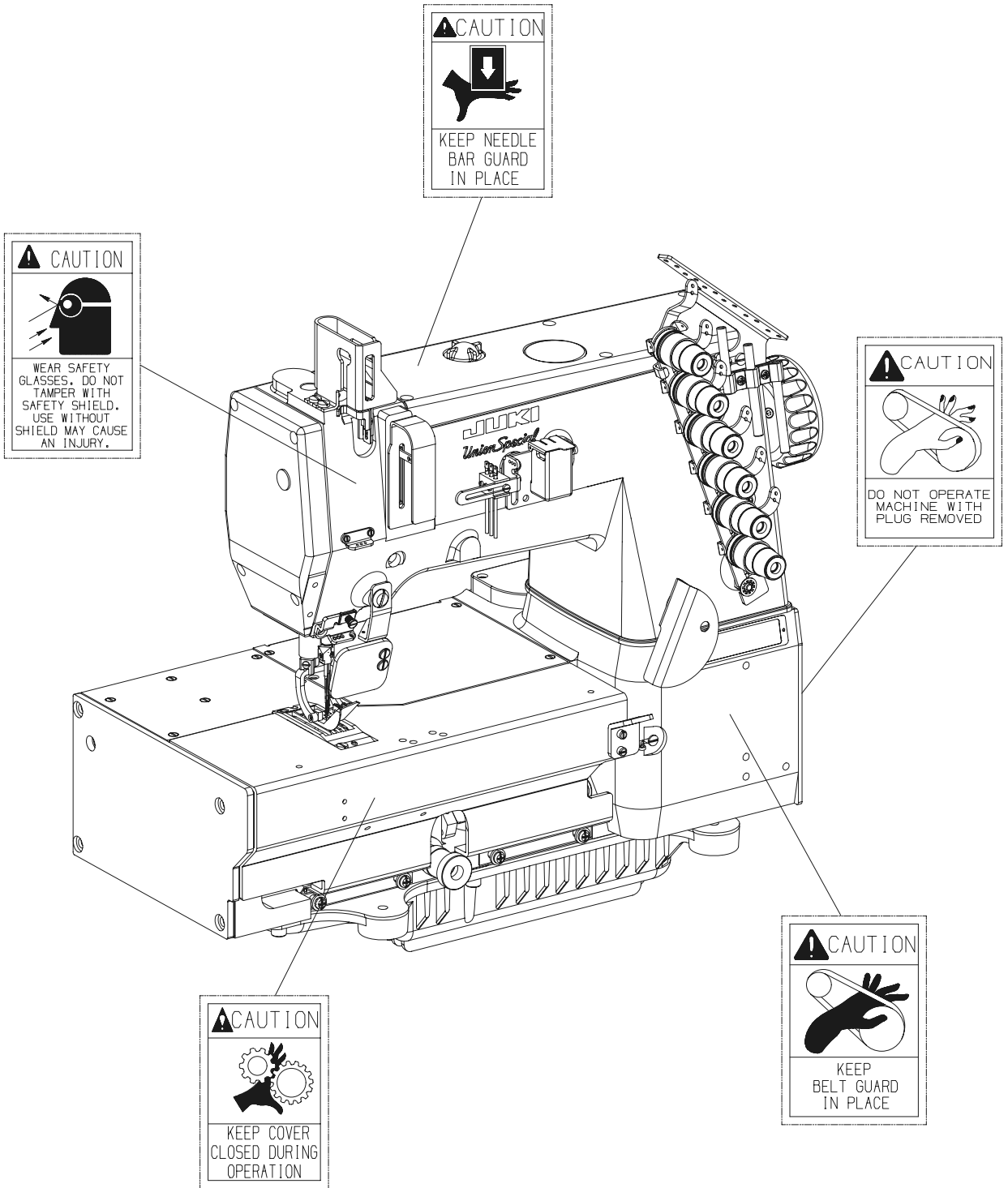

OPERATOR'S DAILY CHECK LIST:

The following should be checked daily and cleaned as required when it applies to your Union Special machine:

- Lint area (clean with compressed air or brush)
- Needle bar bushings
- Under feed dogs & throat plates
- In knives
- In thread control eyelets
- Cooling airways
- In the machine
- In the motor
- In the cooling package
(package is an extra send charge)

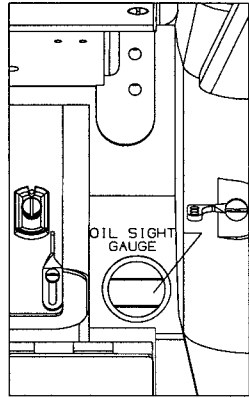

1. The oil level in the sight gauge should be between the two red lines when the machine is at rest. If not, fill with Union Special Specification 175 oil, (Union Special Part No. 28604R).

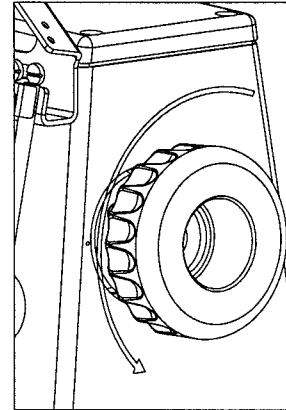

2. The correct rotating direction of the handwheel is counterclockwise, as viewed from the handwheel's side. NEVER run the machine in reverse direction.

OPERATING CAUTIONS:

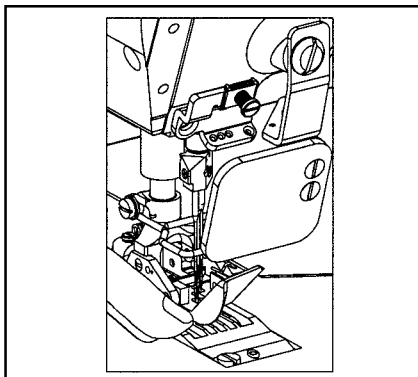

1. Do not put your hand under the needles when turning on the power switch or at any time.

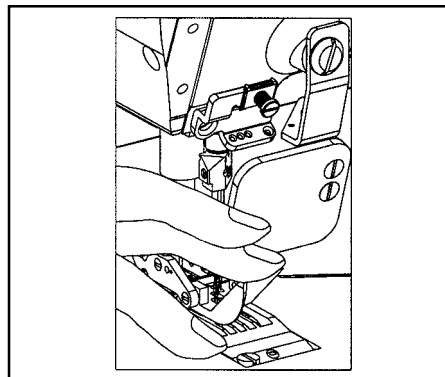

2. Do not put your hand into the sewing area while the machine is running.

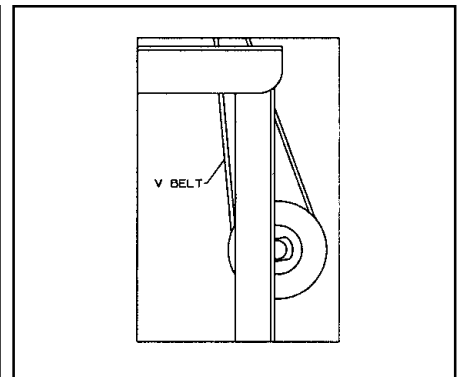

3. Turn off the power switch and make sure the clutch motor is at rest before removing the V belt.

OPERATING CAUTIONS (CONT.):

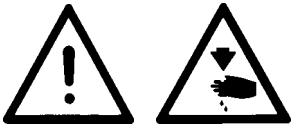

4. During operation, do not allow head, hands or any instrument, tool etc. near handwheel, V belt and motor.
 5. Do not operate your machine without the proper belt guard, sewing guards or any other protectors that have been provided. Doing so is very dangerous.
 6. Before inspecting, adjusting, cleaning, threading the head or replacing needles, turn OFF the power switch. Make sure the flywheel on the motor has stopped, it will be kept running by inertia after turning OFF the power switch. DO NOT depress the foot pedal while the machine is running or it will cause the machine to rotate abruptly.
 7. Turn OFF the power switch when you leave your machine or in case of a power failure.
 8. Do not wipe the machine surface with lacquer thinner.
-

OPERATING THE PEDALS:

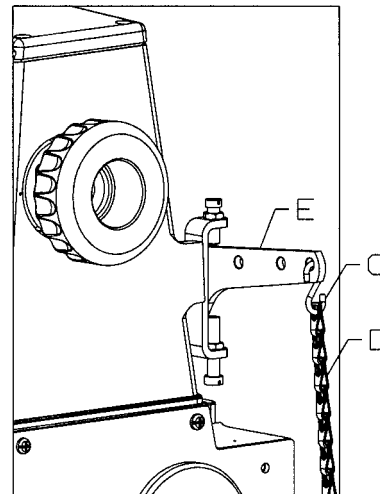
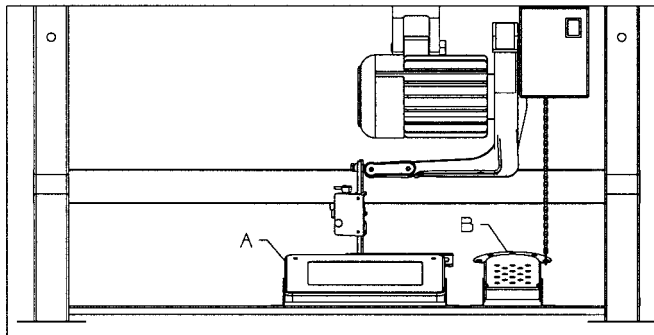

1. Locate the center of drive treadle (A) to be in line with the needles.
2. Locate presser lifter pedal (B) for operator comfort.
3. Use S-shaped hook (C) to connect presser lifter pedal chain (D) to presser lifting lever (E).

LUBRICATION:

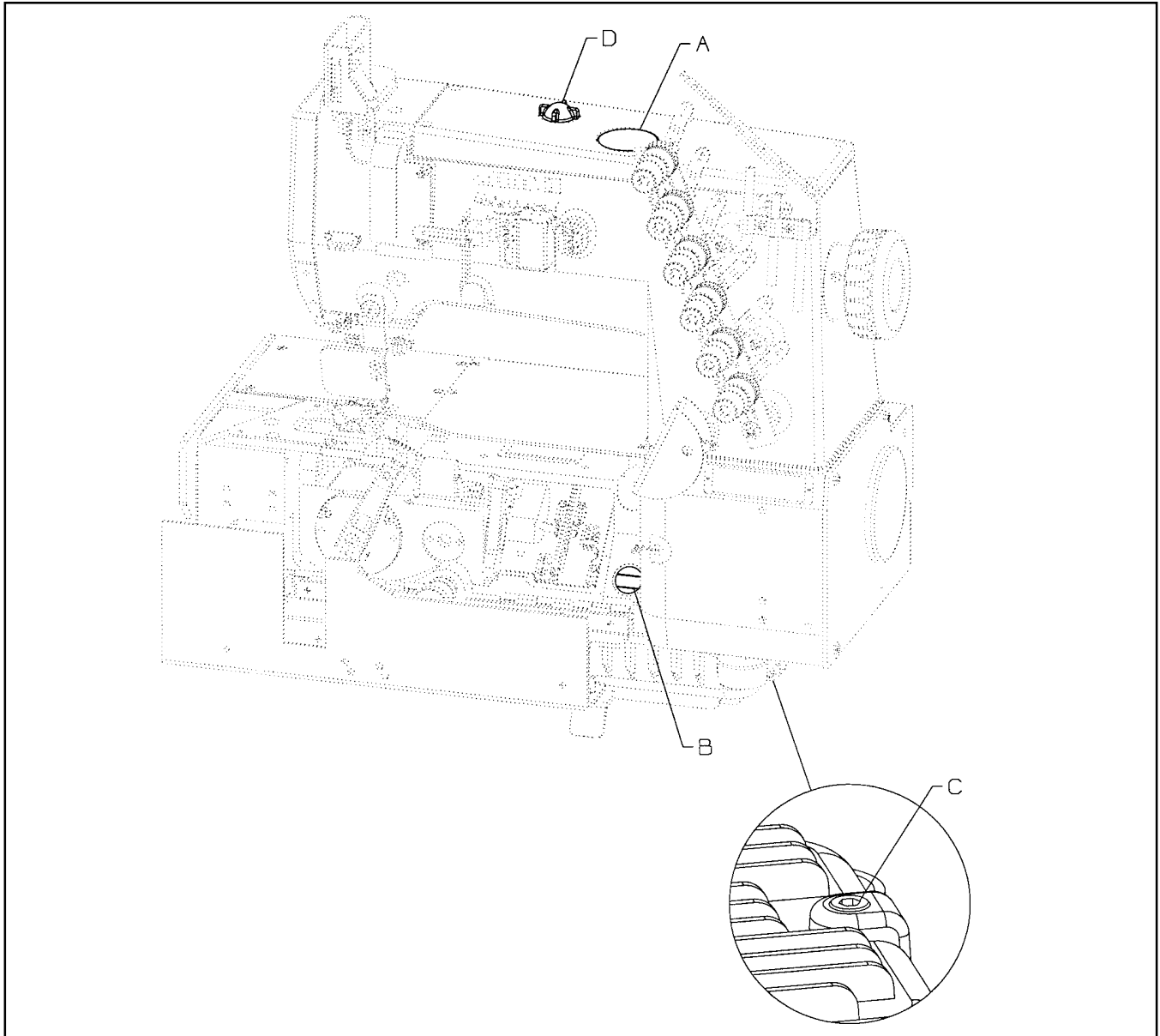

The oil should be between the two red lines in sight gauge (B) when the machine is at rest.

1. If oil is required remove oil cap (A).
2. Fill between lines (B) with Union Special Specification 175 oil (Union Special Part No. 28604R).



CAUTION! Do not exceed the upper red marker line. Excessive oil in the machine will result in oil leakage and possible overheating.

3. To drain oil reservoir, remove oil drain cap (C) on the underside of the machine.
4. To ensure oil flow through machine, check oil flow window (D).

THREADING THE MACHINE:



Turn off main power switch before threading! When using clutch motors without actuation lock wait until the motor has completely stopped.

Thread the machine according to the following threading illustrations.

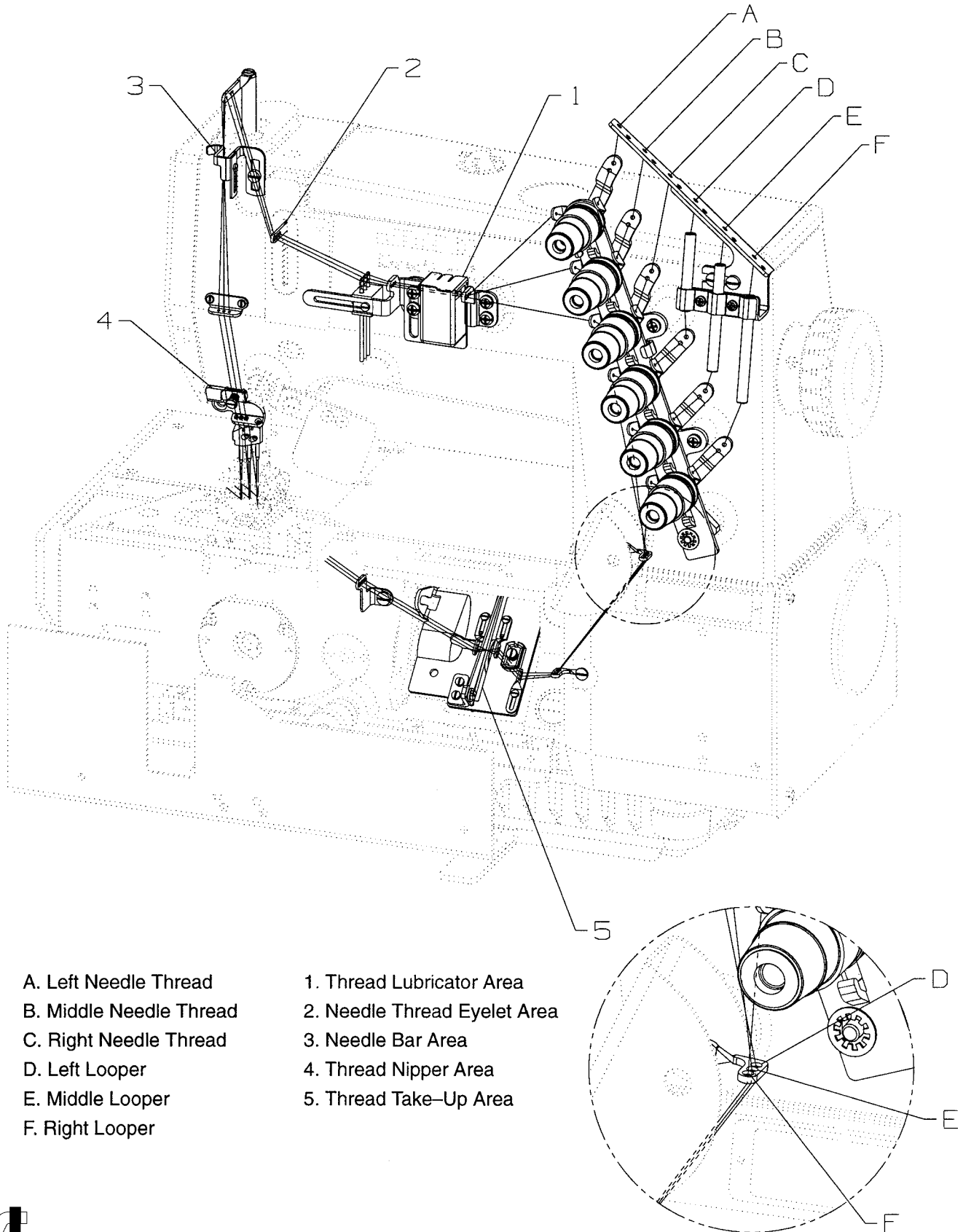

THREADING THE MACHINE (CONT.):

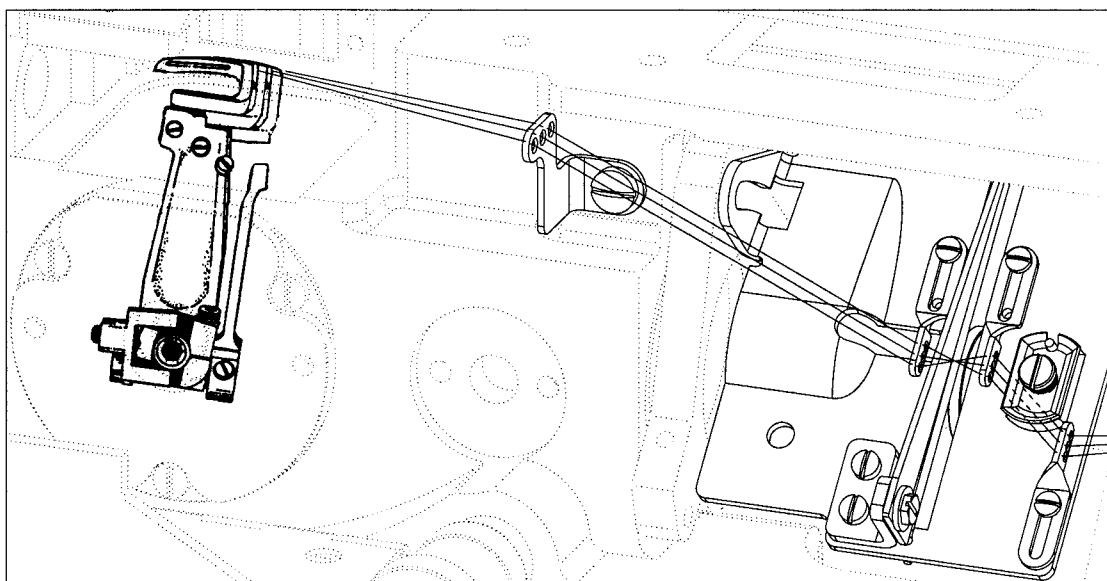
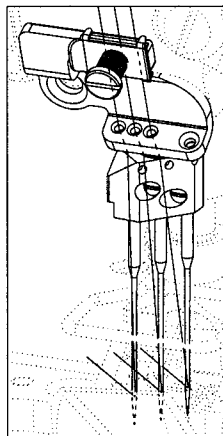
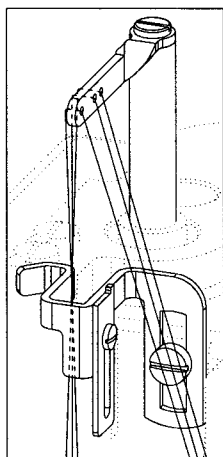
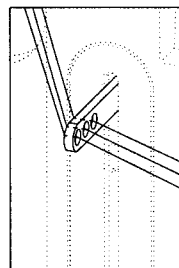
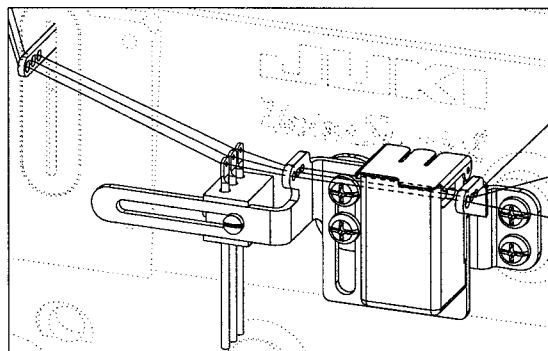

threading the machine (cont.):

When the needle thread lubricator is used:

1. Saturate felt (A).
2. Pass thread over felt.

When the needle thread lubricator is not used:

1. Remove felt (A).

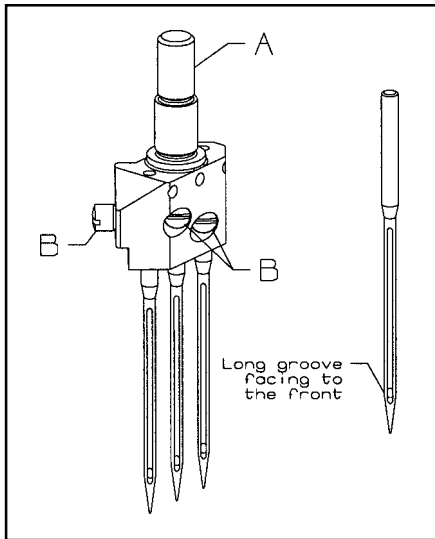
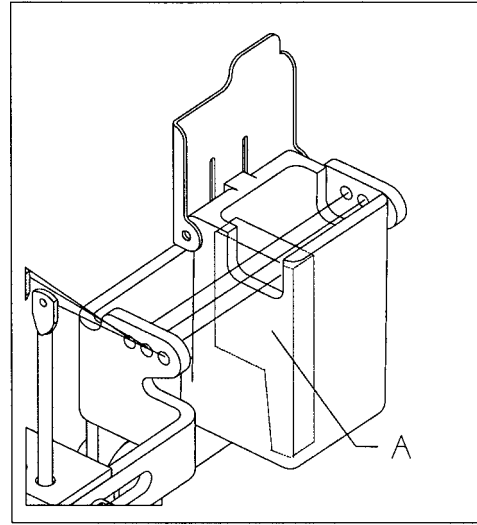

The standard needle is 128 GAS, needle range sizes "090/036 - 150/060."

Insert needle according to the following procedure:

1. Bring needle head (A) to the highest position.
2. Loosen screw (B), insert needle into holes. The needle scarf should face rearwards as viewed from the operator's side.
3. Retighten screw (B).

THREADING METHODS



CAUTION!

When using an untwisted thread such as wooly nylon or weak thread, do not wind it around the intermediate thread guide.

Twisted Thread

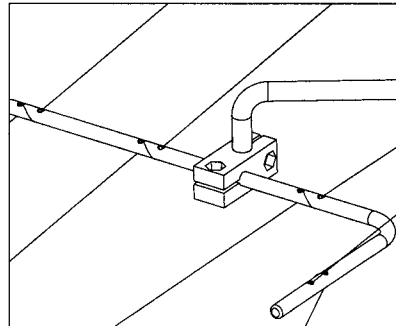

Non-Twist Thread

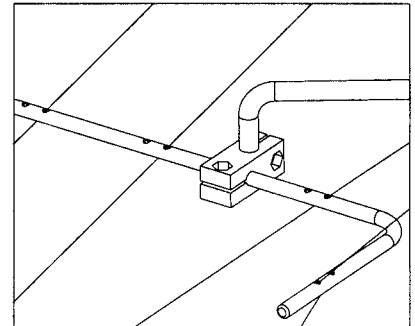

PRESSER FOOT PRESSURE AND LIFTER:

1. Adjust presser foot pressure by loosening nut (A) and turning presser foot adjust screw (B) clockwise to increase the pressure, counterclockwise to decrease the pressure.
2. Retighten nut (A).

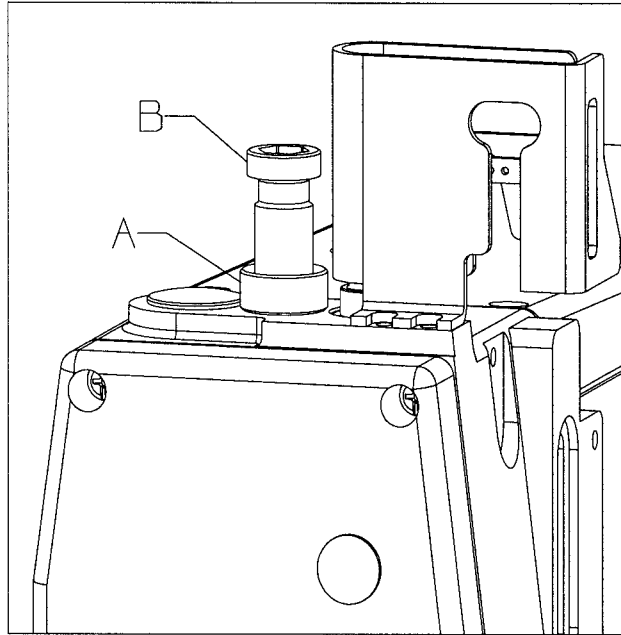

ADJUSTING THE STITCH LENGTH:



Turn off main power switch before setting the stitch length! When using clutch motors without actuation lock wait until the motor has completely stopped.

1. To change stitch length turn stitch regulating screw (A).
Clockwise to increase the stitches per inch/shorten the length of one stitch.
Counterclockwise to decrease stitches per inch/increase the length of one stitch.
2. Numbers 0-11 on stitch regulating screw are for operator's reference only.

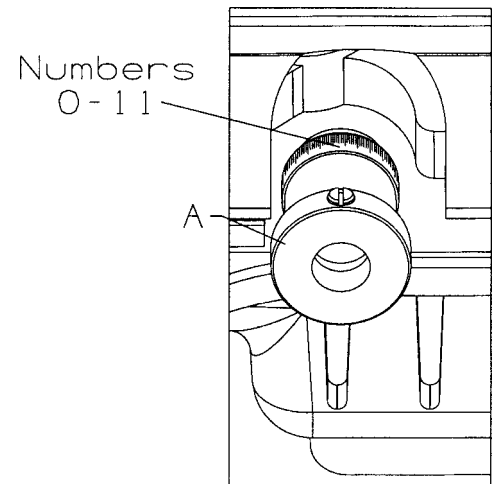

FEED, NEEDLE LOOPER TIMING:

Set the first screw in operating direction of the feed drive eccentrics to be straight up, then, holding this position, set the needle bar at B.D.C.. Set the looper timing to the needles to be synchronized. Adjust the looper timing with the looper avoid drive sprocket.

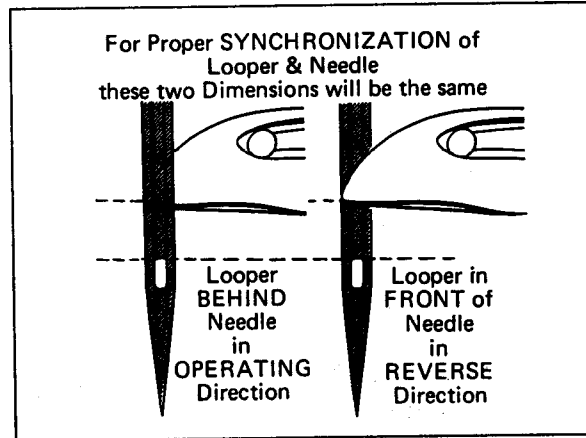

NEEDLE ALIGNMENT:

Torque needle head to 14 to 16 in-lbs (1.6 to 1.8Nm).

Install the feed dog, needles and throat plate. Use the adjustable ferrules to align the needles in the throat plate and align the feed dog so it is centered side to side. Tighten the throat plate support and ferrules in place.

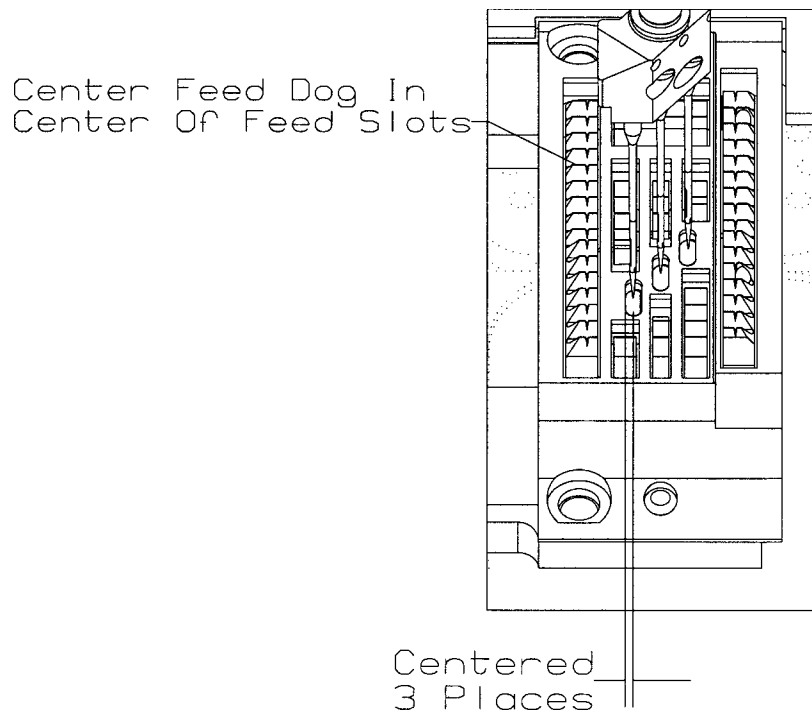

LOOPER SETTING:

Use the right needle and looper to set the looper gauge. Set the looper gauge to 1/8" (3.2mm) when loopers at extreme right. Set the loopers front to back to deflect the needles forward .002" to .006" (.05mm to .10mm). set the looper avoid so the needle touches the back of the looper 2/3 down back as needles descend.

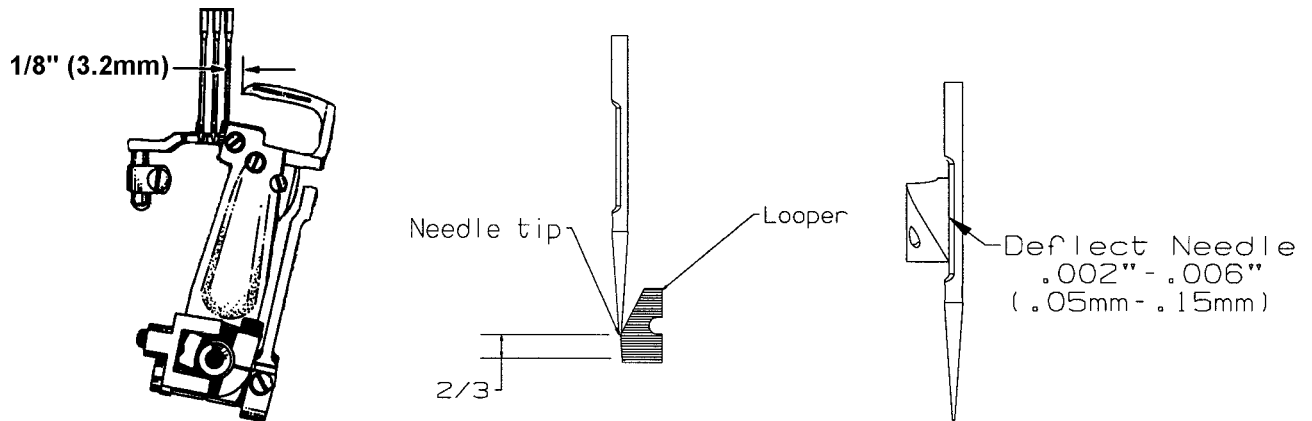

NEEDLE BAR SETTING:

Set the needle height so when the top of the needle eye is even with the bottom of the looper (on it's travel to the left) the looper tip is .020" (.5mm) past the needle. Use the left needle. Recheck looper setting. Torque needle bar clamp screw to the following specifications:

Torque needle bar@
18 to 20 in.-lbs. (2.0 to 2.3Nm)

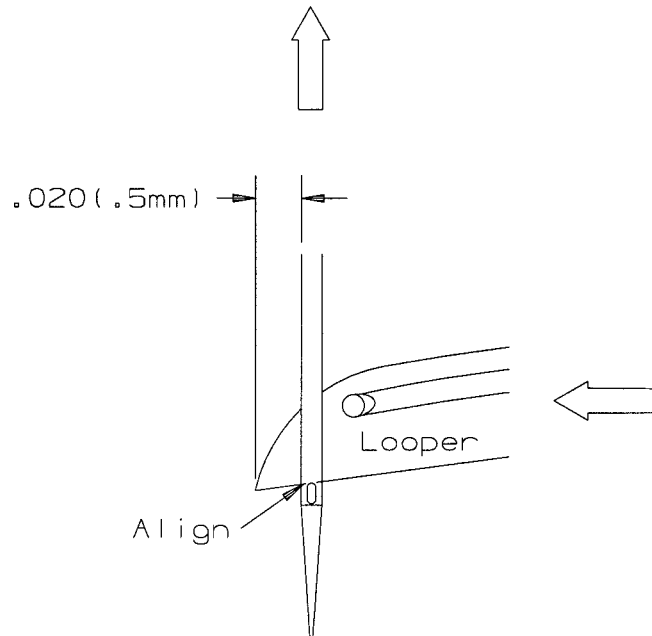

REAR NEEDLE GUARD:

Set the timing of the rear needle guard so the guard reaches it's furthest travel forward as the loopers enter the scarfs on the travel to the left.

Bring the looper tips to the center of the needles in the scarf. The tip of the needles should be $3/64''$ $\pm 1/64''$ (1.2mm $\pm .4$ mm) below the top guarding surface. The guard should just touch the needles up to $.002''$ (.05mm) deflection. The loopers when traveling to the left should just touch the needles to $.002''$ (.05mm) clearance when entering the scarf area.

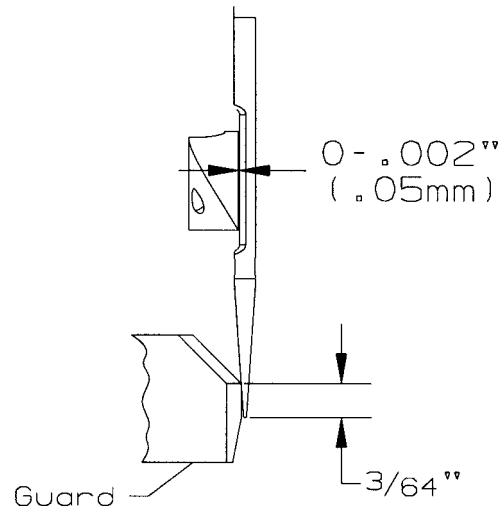
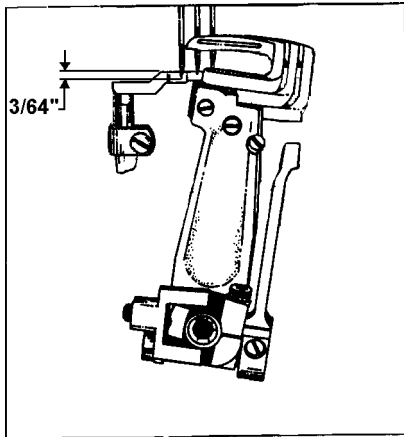

FEED DOG CENTERING AND HEIGHT ABOVE THROAT PLATE:

Set the machine to its longest stitch length. Center feed dog, front to back, so as to obtain equal clearance on the front side and back side of feed dog in the throat plate slots. Set the feed dogs to come out of the throat plate level. Set feed dog height to be full tooth at the rear when the feed dog is at the top of its stroke.

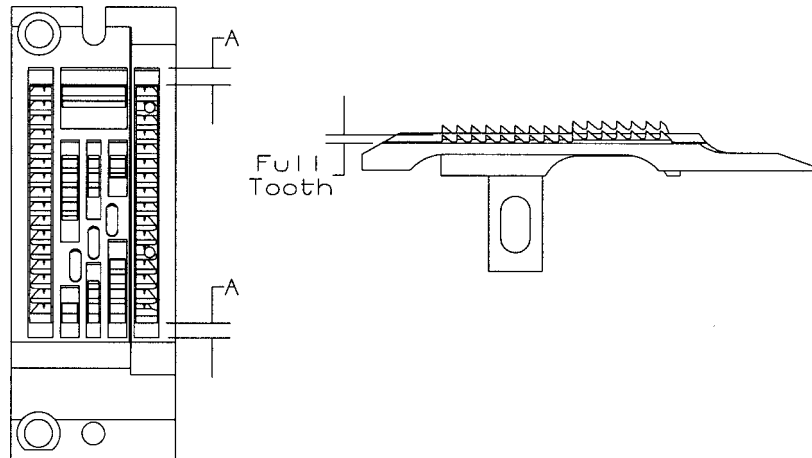

PRESSER FOOT:

Center the needles in the presser foot needle slots. The presser foot lifter lever stop should be set to when the foot is lifted it does not interfere with the needle head when the needle bar is down.



LOOPER THREAD TAKE-UP CAM SETTING:

The looper thread cam should be set so that the looper threads cast off the high lobe of the cam as the point of the needles are just even with the under side of the looper. Set the cast-off plate eyelets so that when the looper reaches its left end of travel, all of the looper thread is used and no thread is drawn from the cone. Move down for less. Set the retaining finger so that the finger is even with the bottom edge of its holder and the tip on the right side is touching the cast-off plate.

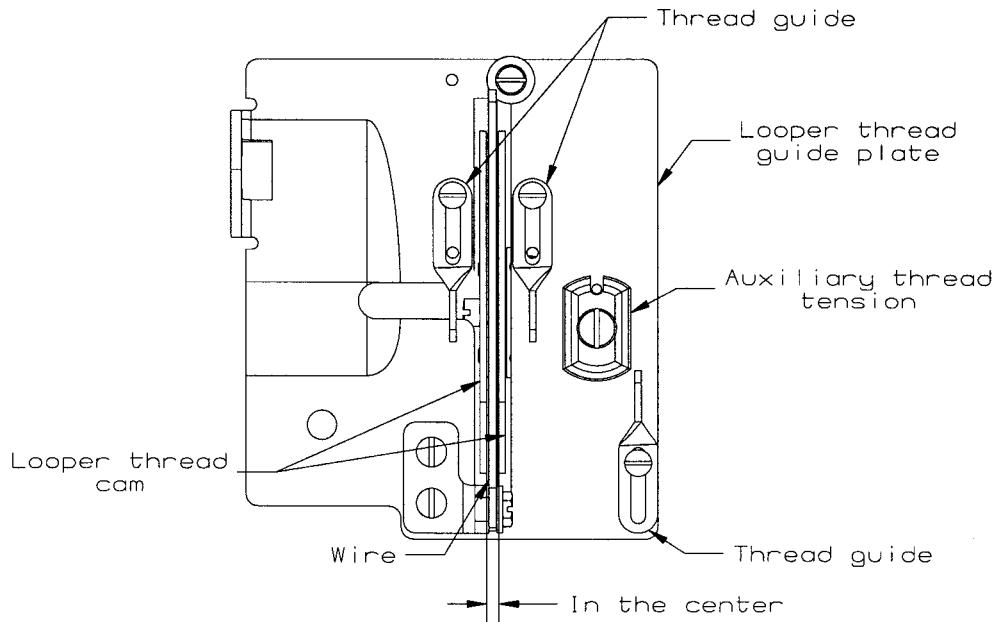

THREAD CONTROL:

Set the individual needle thread eyelets so they are 25mm below the top casting and to the extreme right when using the mount adapter.

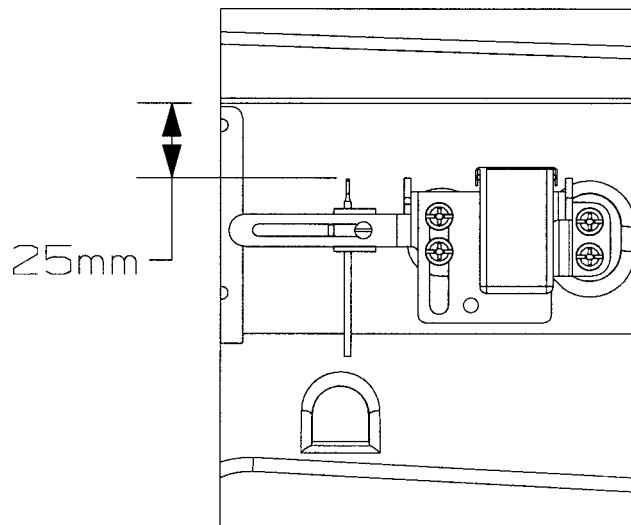

PULLER ADJUSTMENTS:

With the roller resting on the top of the throat plate, the stop collar should be set about 15mm above the ledge of the puller casting where the stop screw rests. Set the stop screw to rest on the casting and lock in place. Set the lifter lever block to have 0.05mm to 0.15mm clearance above the lifter lever in the neutral position.

Note: When changing sprockets, if the total number of teeth on both sprockets is different than what was on the puller, check and readjust these settings.

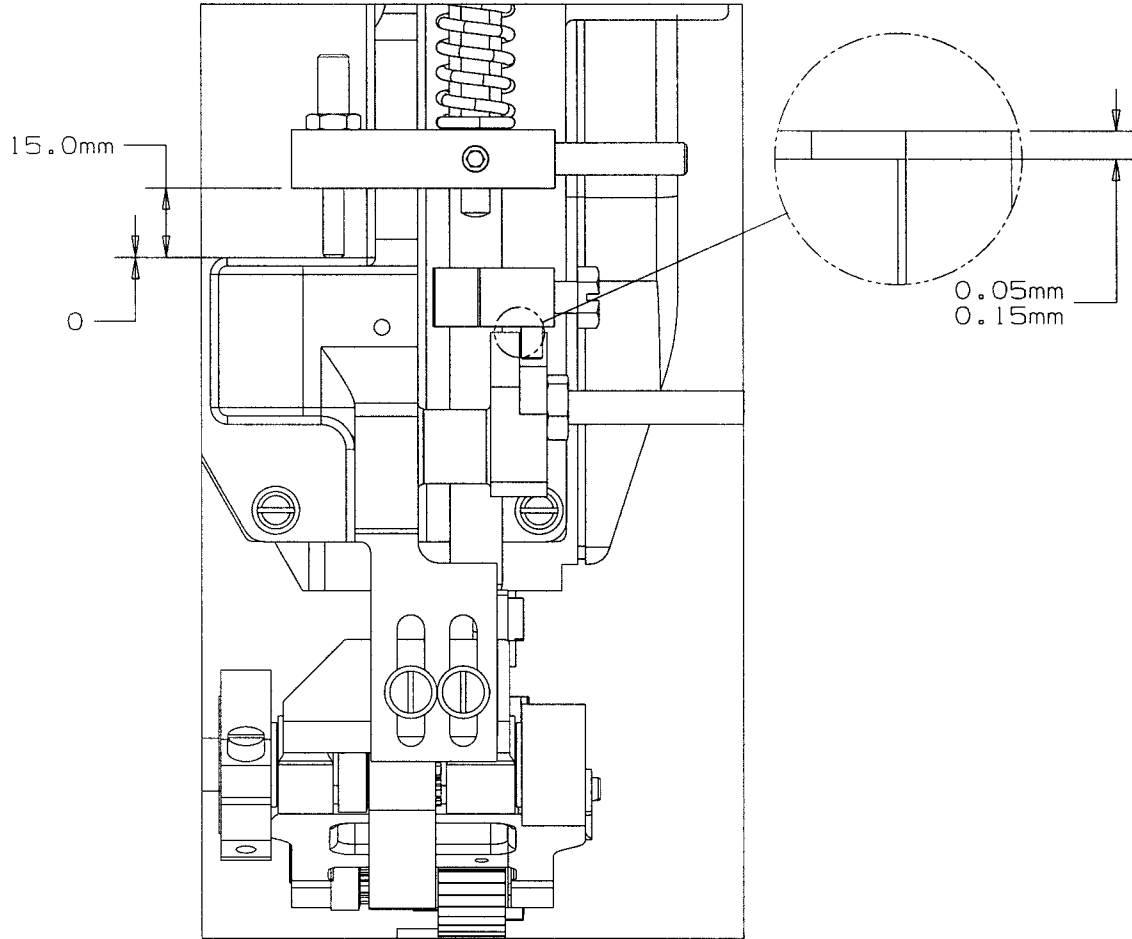

Use the puller tension nut to add or remove pressure from the roller.

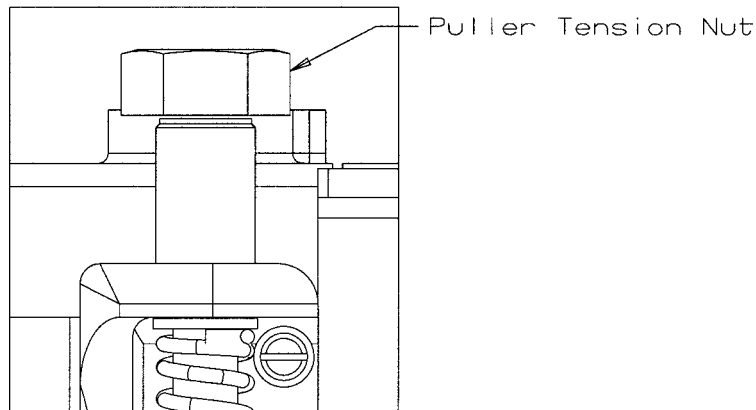

PULLER ADJUSTMENTS CONT.:

When assembling the puller to the machine, make sure that a minimum of .05 clearance is maintained between the roller and the throat plate step. Also the roller must sit flat on the throat plate.

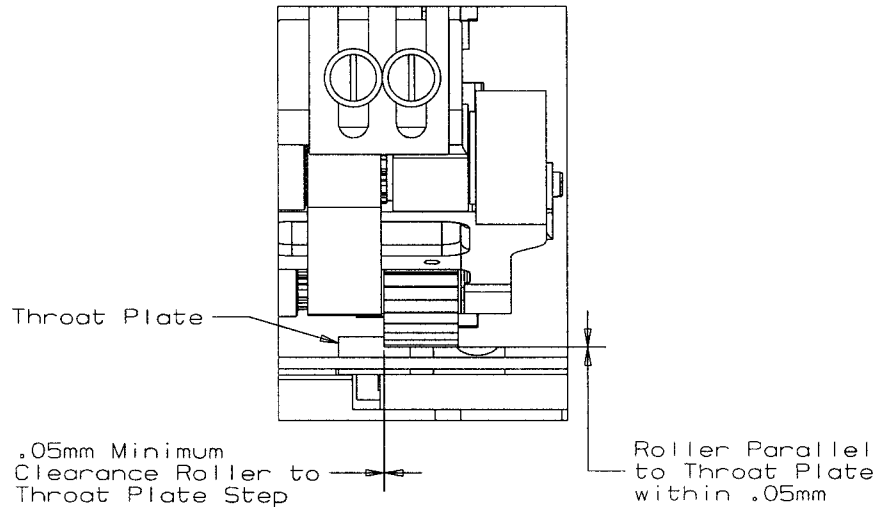

Time the puller so the roller feeds at the same time the feed dog is feeding. When setting, both should be feeding at the same S.P.I.. Adjust the timing by using the sprocket on the upper main shaft in the arm.

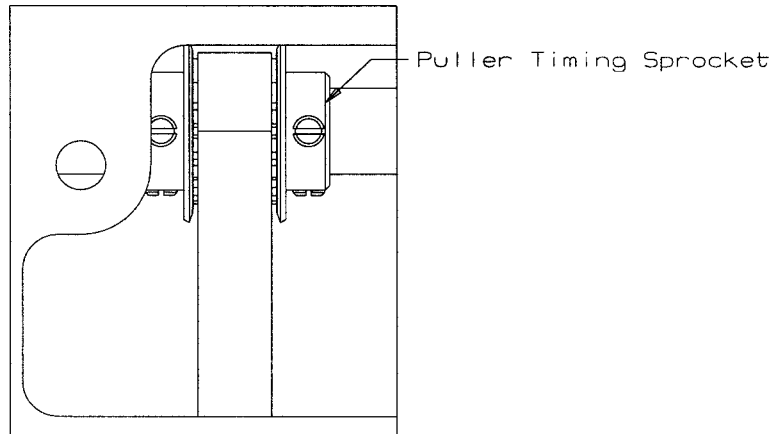

PULLER SPROCKET COMBINATIONS		
PULLER DRIVE SPROCKET	PULLER SPROCKET	S.P.I. ±1/2 STITCH
14	15	8
14	14	7 1/2
15	14	7
15	13	6 1/2
13	15	8 1/2
13	16	9
16	13	6
12	16	9 1/2
11	16	10



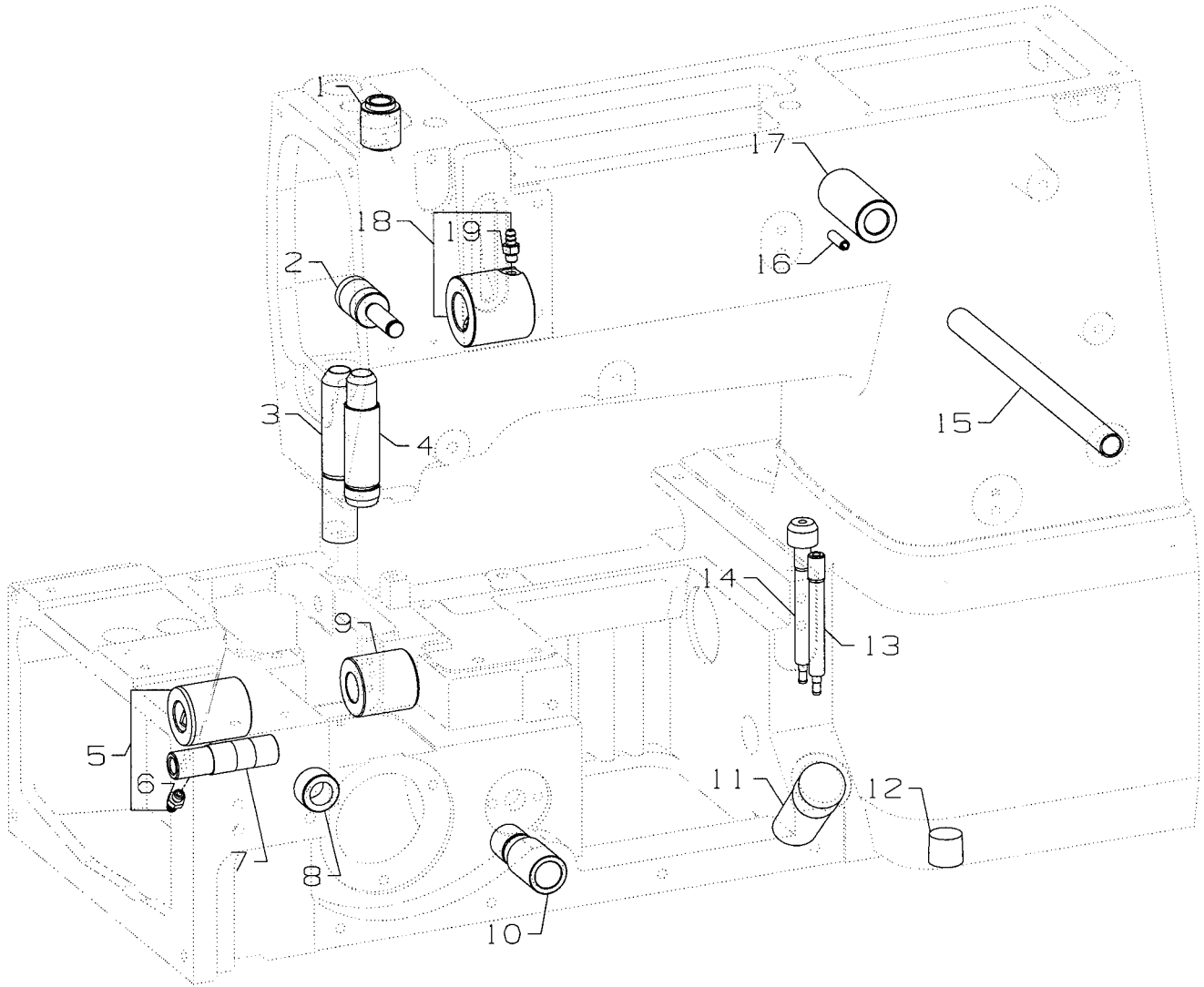

BUSHINGS

Ref. No.	Part No.	Description	Amt. Req.
1.	50654	Bushing, for needle bar, upper	1
2.	50332U	Pin, for front lifter lever	1
3.	50330CZ	Bushing, for presser bar	1
4.	50654A	Bushing, for needle bar, lower	1
5.	50344BE	Bushing, for lower mainshaft, left	1
6.	SQ1110401MZ	Fitting	1
7.	50344BC	Bushing, for needle lever	1
8.	50344E	Bushing	1
9.	50344BF	Bushing, for lower mainshaft, right	1
10.	35036BS	Stitch Regulator Bushing	1
11.	50393GE	Oil Sight Gauge	1
12.	22571L	Screw, for drain plug	1
13.	50393FU	Fitting, oil tube	1
14.	50393EY	Fitting, filter	1
15.	50392AB	Bushing, for tension release.....	1
16.	PS0400142KH	Pin	1
17.	50381E	Bushing, for lifter lever, back	1
18.	50344BU	Bushing, front	1
19.	SQ1110401MZ	Fitting	1



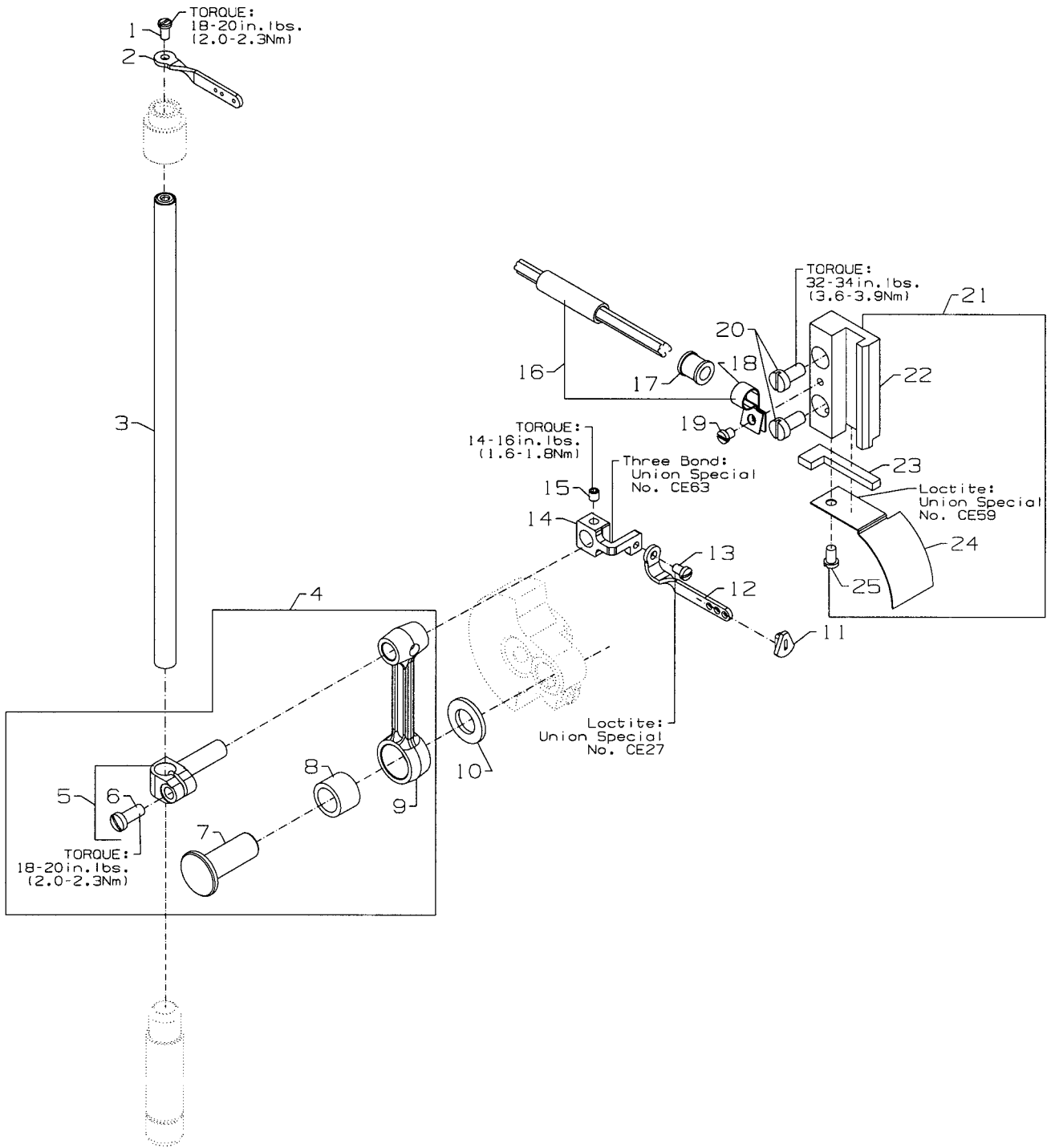

NEEDLE BAR

Ref. No.	Part No.	Description	Amt. Req.
1.	SS4080620TP	Screw	1
2.	50323P	Needle Bar Eyelet	1
3.	50317B	Needle Bar	1
4.	50345W	Connecting Rod Assembly	1
5.	50355AM	Needle Bar Clamp	1
6.	SS7111120TP	Screw	1
7.	50352	Pivot Pin	1
8.	661-259B	Needle Bearing Cage	1
9.	50355AN	Connecting Rod	1
10.	50351A	Washer	1
11.	50393JP	Eyelet Seal	1
12.	50358X	Needle Thread Eyelet	1
13.	SS7080520SP	Screw	1
-	CE27	Loctite Adhesive, (not shown), for screw	-
14.	50354F	Slide Block	1
-	CE63	Three Bond Adhesive, (not shown), for slide block	-
15.	SS8110422TP	Screw	1
16.	29476TC	Oil Tube Assembly	1
17.	50393JZ	Oil Tube	1
18.	50393JW	Hose Clamp	1
19.	SS6090440SP	Screw, for oil tube assembly	1
20.	SS6121010SP	Screw	2
21.	29476VN	Slide Block Guide and Cover Assembly	1
22.	50338	Guide, for slide block	1
23.	666-328	Felt, for slide block	1
-	CE59	Loctite Adhesive, (not shown), for felt	-
24.	50338A	Cover, for guide	1
25.	SS6090620SP	Screw	1



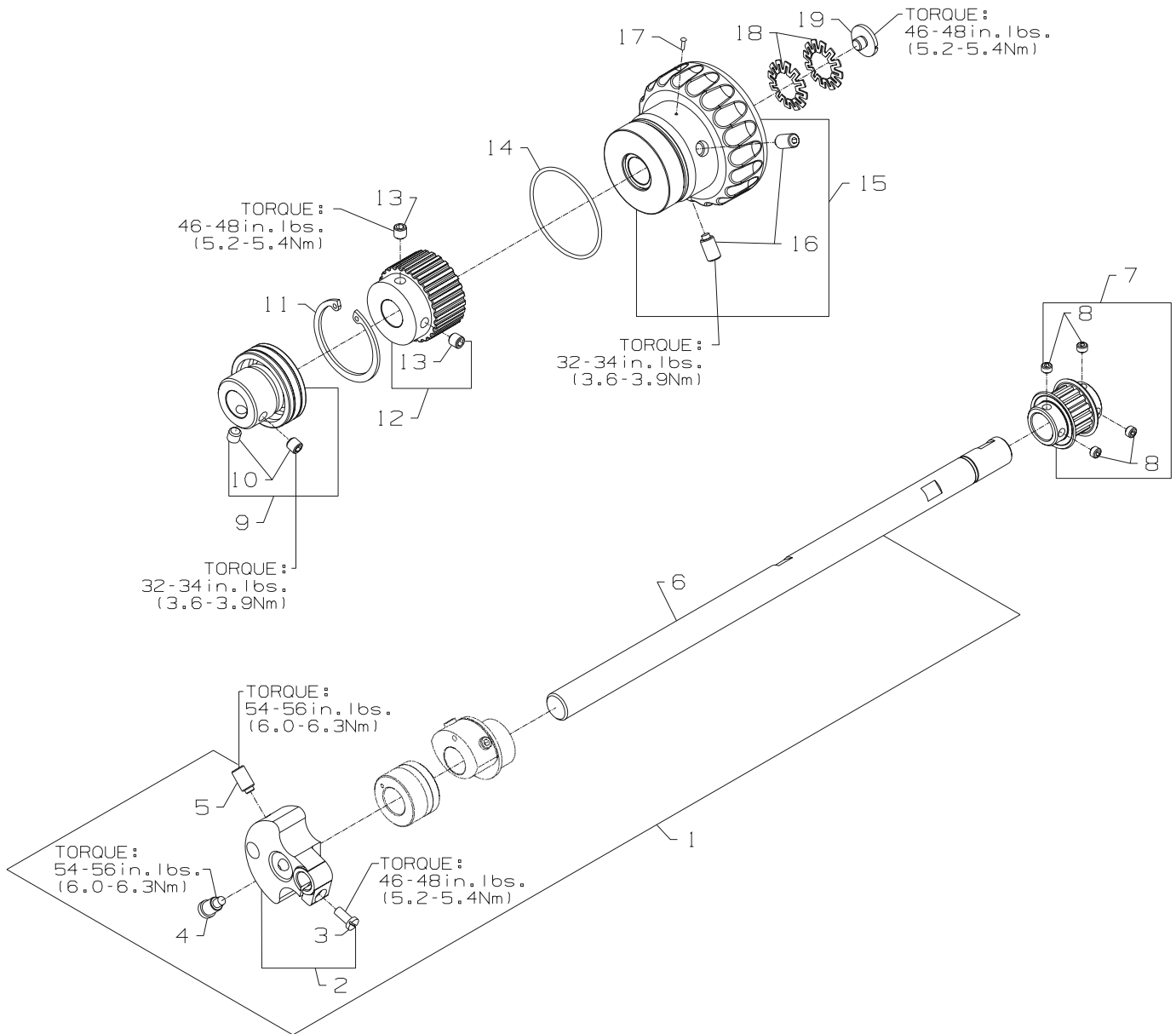

UPPER MAIN SHAFT

Ref. No.	Part No.	Description	Amt. Req.
1.	50322BC	Upper Main Shaft Assembly	1
2.	50691	Counter Weight	1
3.	SS7111120TP	Screw, for counter weight	1
4.	SS7681410TP	Screw, for counter weight	1
5.	SS8681412TP	Screw, for counter weight	1
6.	50322AF	Upper Main Shaft	1
7.	50642A	Sprocket, Main Drive	1
8.	22894T	Screw	4
9.	50335BD	Bearing Adapter Assembly	1
10.	SS8660612TP	Screw, for bearing adapter	2
11.	661-262	Retaining Ring	1
12.	50342BE	Sprocket, for upper main shaft	1
13.	SS8661012TP	Set Screw, for sprocket	2
14.	660-1087	"O" Ring.....	1
15.	50321F	Handwheel	1
16.	SS8681412TP	Set Screw, for handwheel	2
17.	660-1043	Tack Pin, for handwheel	1
18.	661-261	Load Ring, for lower main shaft	2
19.	SS7660520SP	Screw, for handwheel preload	1



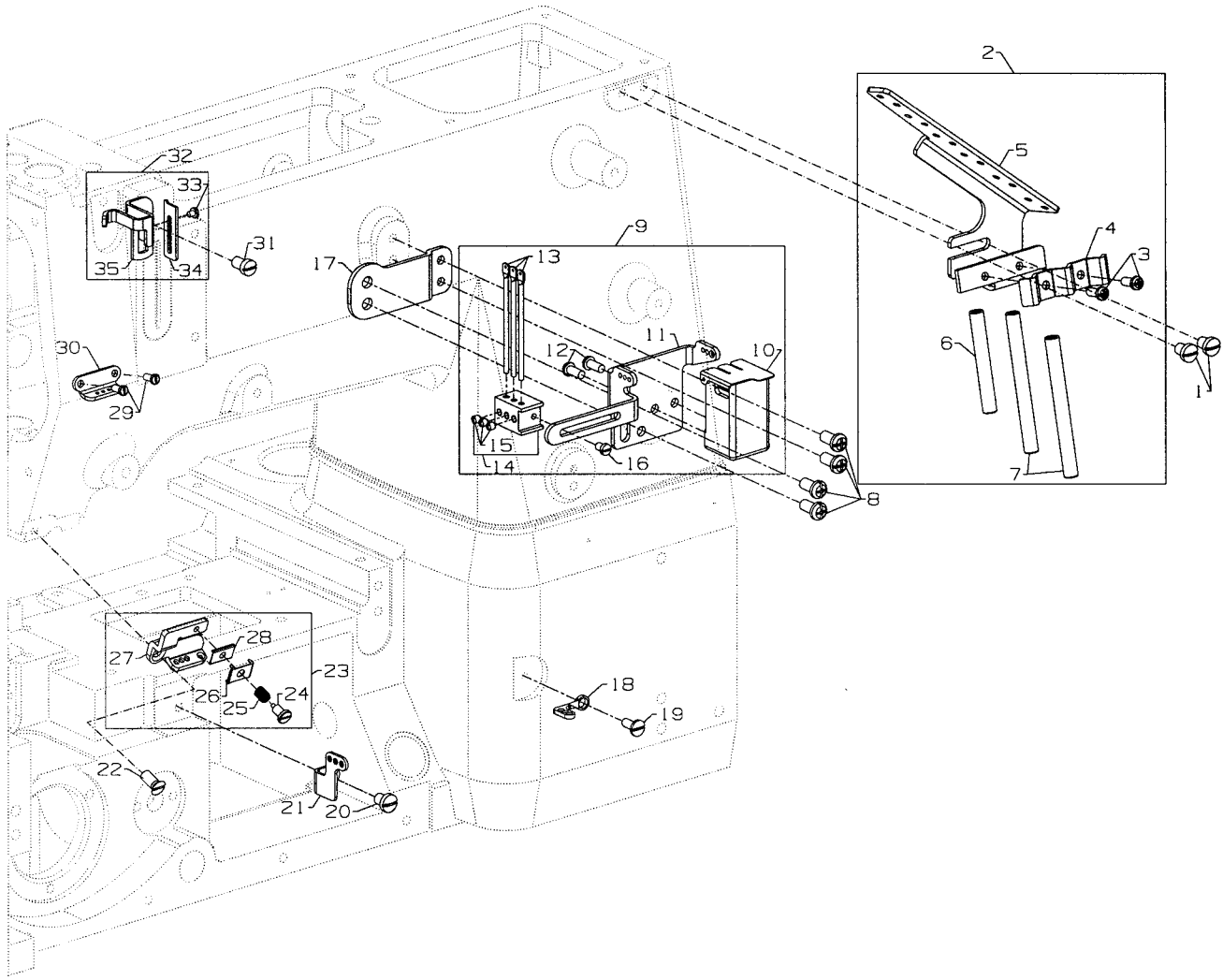

THREAD GUIDE

Ref. No.	Part No.	Description	Amt. Req.
1.	SS7120640SP	Screw, for lead-in eyelet	2
2.	50666A	Thread Eyelet Assembly	1
3.	SS4090815SP	Screw	2
4.	50666	Tube Bracket	2
5.	50692E	Lead-In Tension Eyelet	1
6.	50666C	Thread Tube	1
7.	50366	Thread Eyelet Tube	2
8.	SS4120915SP	Screw, for spreader thread guide	2
9.	50663A	Thread Ratio Control Assembly	1
10.	50393HH	Silicone Thread Lubricator	1
11.	50392V	Needle Thread Guide	1
12.	SS4090815SP	Screw, for silicone tank	2
13.	36271A	Adjusting Needle Thread Eyelet	3
14.	50358W	Holder, For Needle Thread Eyelet	1
15.	SS8080410TP	Screw	3
16.	SS7080510TP	Screw	1
17.	50683	Mounting Bracket	1
18.	50658B	Looper Frame Eyelet	1
19.	SS7090610SP	Screw	1
20.	SS7120640SP	Screw	1
21.	50658A	Looper Frame Eyelet	1
22.	SS1121010SP	Screw, for thread guide	1
23.	50357AE	Nipper Plate Assembly	1
24.	SD0380551SL	Screw	1
25.	50357AS	Nipper Spring	1
26.	50357Y	Nipper Spring Plate	1
27.	50392BA	Thread Guide	1
28.	50357V	Nipper Plate	1
29.	605A	Screw, for needle thread guide	2
30.	C50044E	Needle Thread Guide	1
31.	SS7120710SP	Screw, for strike-off	1
32.	50366B	Needle Thread Strike-Off Assembly	1
33.	SS7060310SP	Screw	1
34.	50370F	Thread Strike-off Component	1
35.	50358V	Needle Thread Strike-off	1



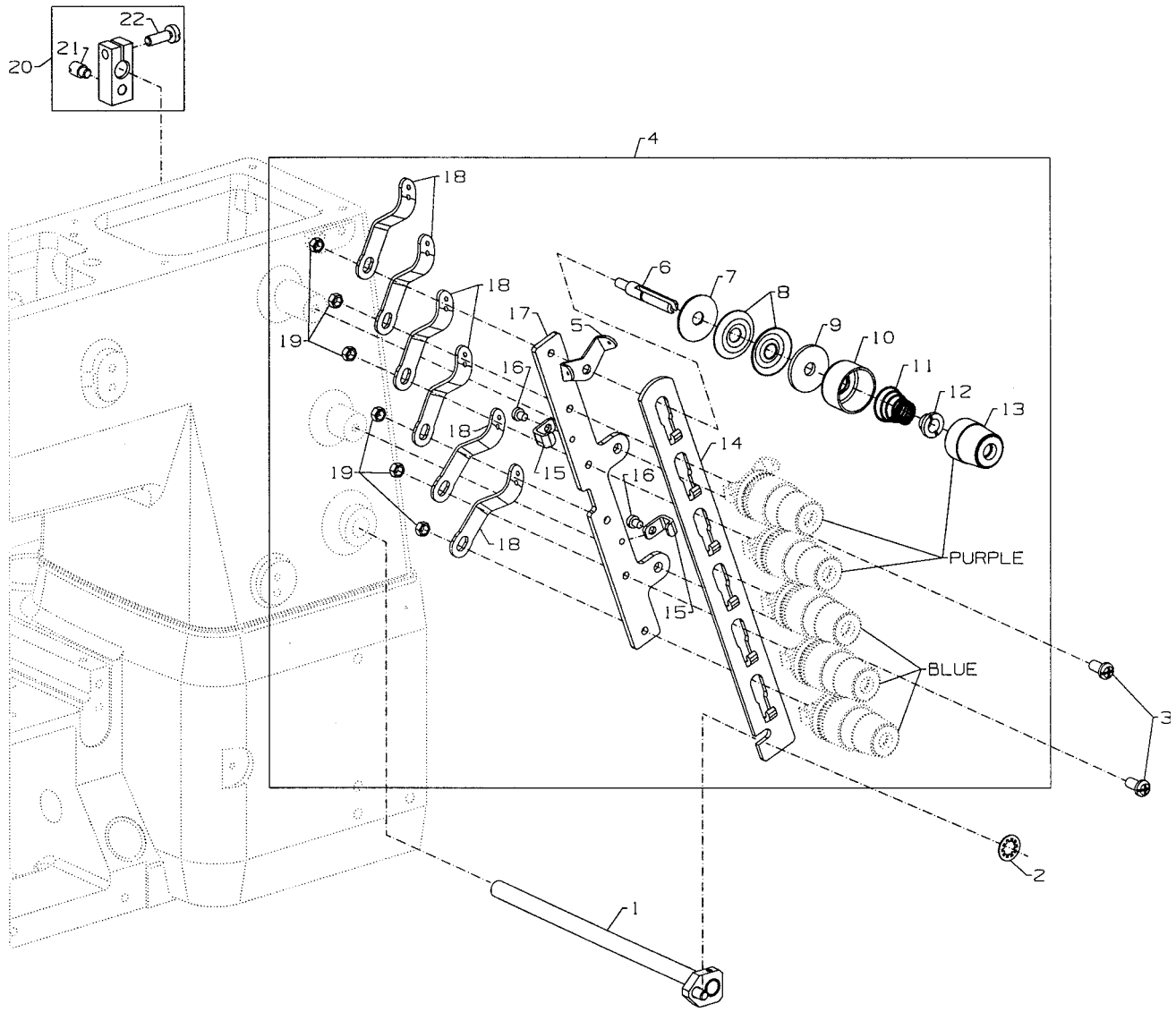

TENSION RELEASE & THREAD TENSION

Ref. No.	Part No.	Description	Amt. Req.
1.	50392Z	Tension Needle Lever Assembly	1
2.	660-283A	Retainer Washer	1
3.	SS4120915SP	Screw, for tension assembly	2
4.	50692D	Six Thread Tension Assembly	1
5.	57892K	Thread Tension Eyelet	6
6.	56392G	Tension Post	6
7.	B3120352000	Tension Disc Felt	6
8.	B3126012000	Tension Disc	12
9.	B3120704000	Tension Disc Felt	6
10.	56392H	Spring Shield	6
11.	11550100	Spring, needle (Purple)	3
-	B3103800400	Spring, looper (Blue)	3
12.	B3112704000	Ferrule, tension spring	6
13.	50692J	Knob, needle (Purple)	3
-	56392M	Knob, looper (Blue)	3
14.	50692	Tension Disc Separator	1
15.	50392AV	Guide, for tension disc separator	2
16.	SS7090520SP	Screw, for guide	2
17.	50692A	Tension Bracket	1
18.	57865	Lead-In Thread Guide	6
19.	NS6110420SP	Nut	6
20.	50392BC	Tension Release Lever Shaft Connection	1
21.	22875N	Stop Screw	1
22.	SS7121410TP	Binder Screw	1



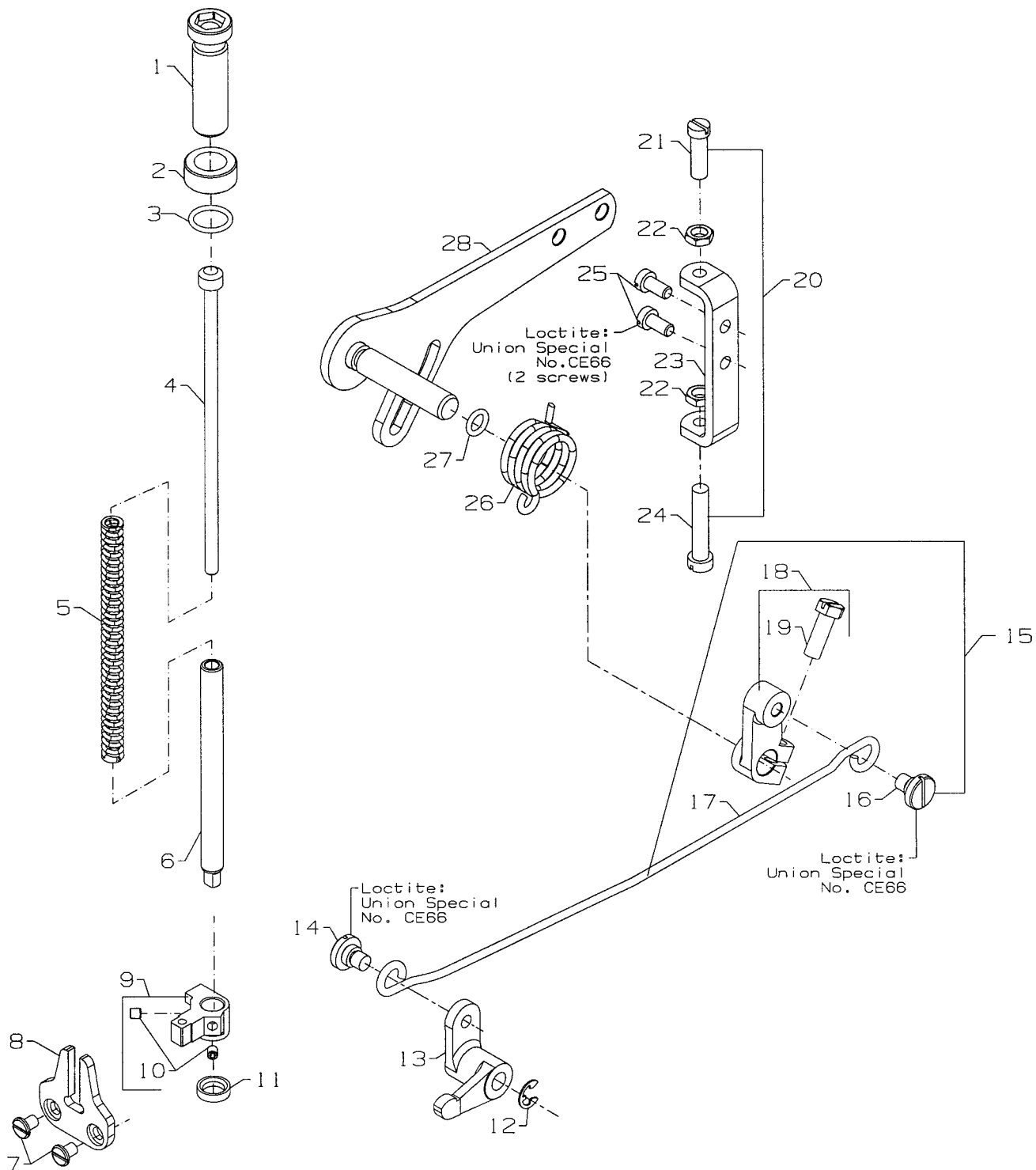

PRESSER FOOT LIFT

Ref. No.	Part No.	Description	Amt. Req.
1.	11071602	Adjusting Screw, for spring	1
2.	11071701	Locking Nut	1
3.	660-1014	"O" Ring	1
4.	C50056B	Spring Rod	1
5.	50632A	Spring, for presser bar	1
6.	50643C	Presser Bar	1
7.	SS6110610TP	Screw, for guide plate	2
8.	50335AG	Guide Plate, for presser bar	1
9.	50335AH	Presser Bar Guide	1
10.	SS8110422TP	Set Screw	2
11.	660-739	Oil Seal	1
12.	RE0500000K0	E Ring, for pin	1
13.	50381F	Lever, for lifter, front	1
14.	SD0790303SP	Screw, for wire connector	1
-	CE49	Loctite Adhesive, (not shown), for screw	-
15.	29476YD	Rear Lifter Lever Assembly	1
16.	SD0790303SP	Screw, for lifter lever assembly	1
17.	50355AR	Wire Connector	1
18.	50381G	Lifter Lever, rear	1
19.	SS9151740CP	Hex Screw	1
20.	29476TT	Stop Assembly	1
21.	SS6151920SP	Screw, for adjusting stopper	1
22.	NS6150310SP	Hex Nut	2
23.	50332V	Stopper, for lifter lever	1
24.	SS6153040SP	Screw, for adjusting stopper	1
25.	SS4121215SP	Screw, for stopper	2
-	CE49	Loctite Adhesive, (not shown), for screw	-
26.	50381	Spring, for lifter lever	1
27.	RO068190100	"O" Ring	1
28.	50381B	Lifter Lever Assembly	1



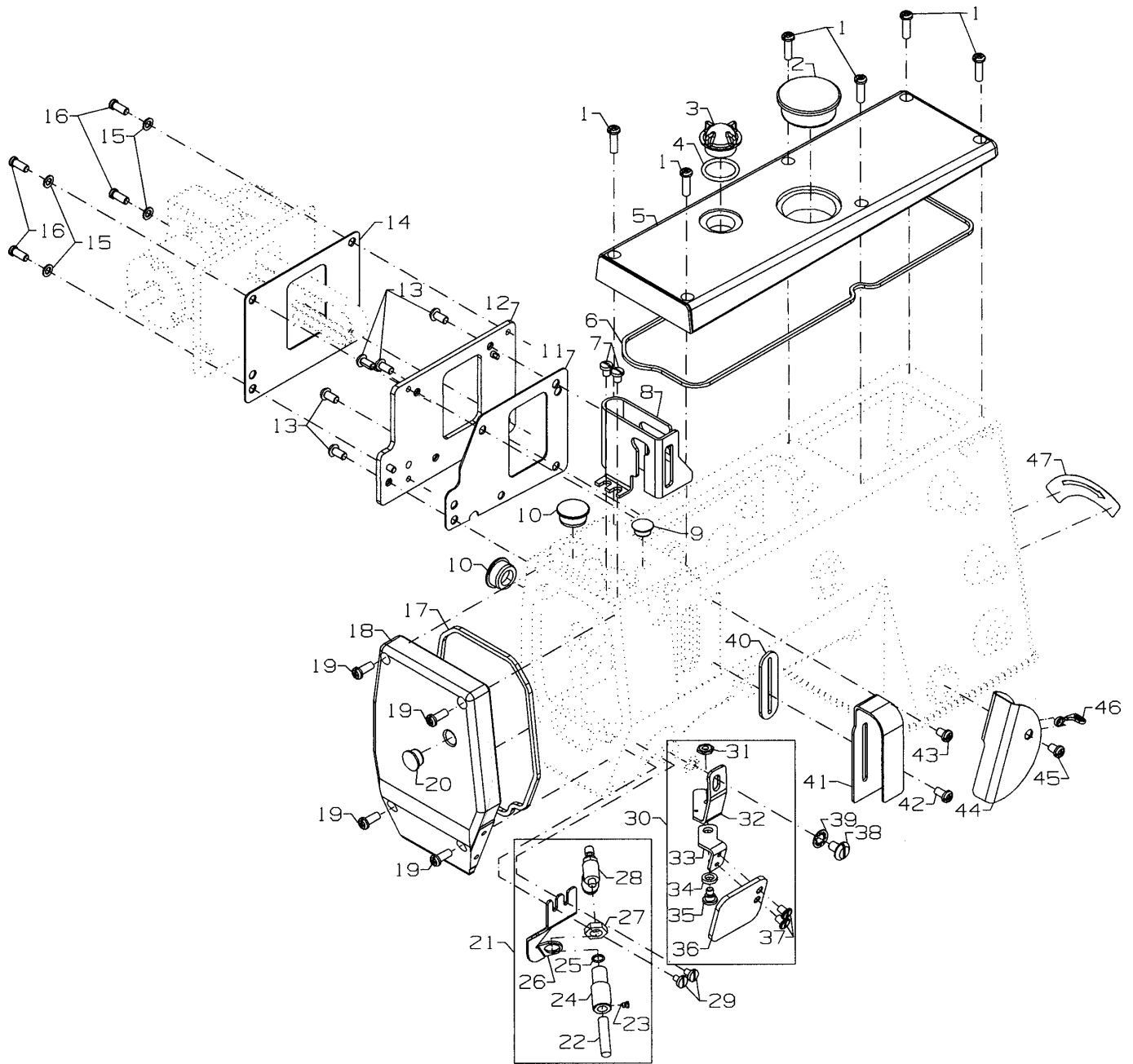

COVERS, UPPER ARM

Ref. No.	Part No.	Description	Amt. Req.
1.	SS4121615SP	Screw, for top cover	6
2.	50393EU	Plug, for top cover	1
3.	B3530555000	Oil Sight Gauge, top	1
4.	660-212	"O" Ring, for oil sight gauge	1
5.	50382FW	Top Cover	1
6.	50382FZ	Quad Ring, for top cover	1
7.	SS7120640SP	Screw, for needle bar guard	2
8.	50317C	Needle Bar Guard	1
9.	TA1050504RO	Plug, for bed	1
10.	50393HB	Plug, for bed	2
11.	50684C	Gasket, for puller drive Adapter	1
12.	50662A	Puller Drive Adapter	1
13.	SS6121050SP	Screw, for puller drive adapter	5
14.	50684B	Gasket, for Puller Drive Housing	1
15.	WP0480856SP	Washer	4
16.	22569B	Screw	4
17.	50382FY	Quad Ring, for head cover	1
18.	50382FX	Head Cover	1
19.	SS4121215SP	Screw, for head cover	4
20.	TA1100604RO	Plug, for head cover	1
*21.	21237EV	Needle Cooler Assembly	1
*22.	21237DR	Cooler Tube	1
*23.	22784N	Screw	1
*24.	21237ET	Cooler Housing	1
*25.	660-886	O-Ring	1
*26.	21237EU	Bracket	1
*27.	51170D	Nut	1
*28.	671-102A	Flow Control	1
*29.	SS7090610SP	Screw	2
30.	99682XCA	Protection Shield Assembly	1
31.	NS6620320SP	Nut	1
32.	99682XC1	Bracket Holder	1
33.	99682XC2	Bracket	1
34.	WZ0641510KP	Spring Washer	1
35.	SD0640323TP	Shoulder Screw	1
36.	99682XC	Protection Shield	1
37.	SS1110640SL	Counter Sunk Head Screw	2
38.	22517B	Screw	1
39.	652C16	Washer	1
40.	50393EW	Rubber Gasket, for needle lever	1
41.	50382GA	Cover, for thread take-up	1
42.	SS4120915SP	Screw, for thread take-up cover	1
43.	SS4120615SP	Screw, for thread cover	1
44.	50382GM	Thread Cover	1
45.	SS4120615SP	Screw, for thread take-up cover	1
46.	50658B	Eyelet	1
47.	LA452	Label, direction of rotation	1

* PA1 KIT ONLY



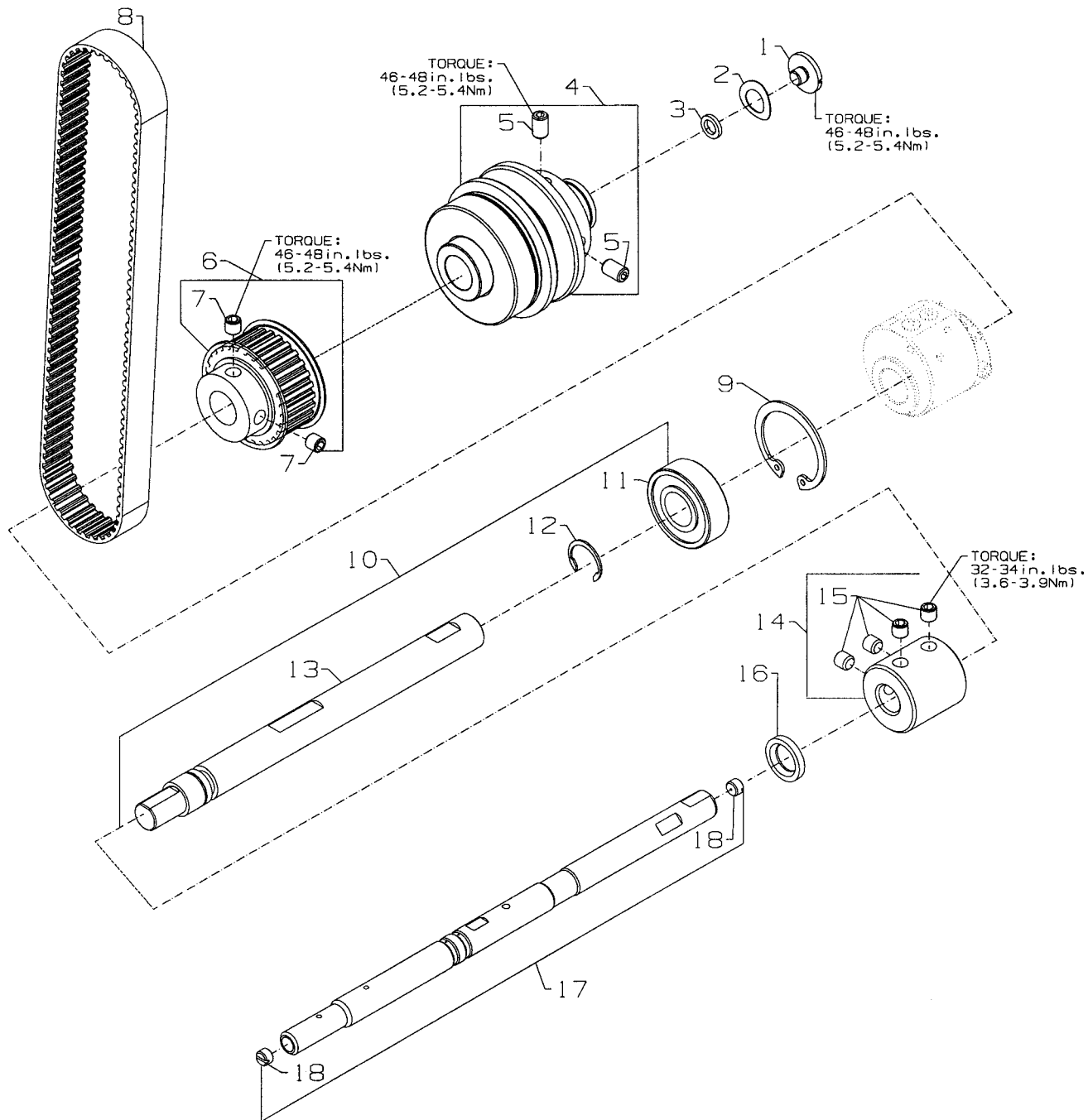

LOWER MAIN SHAFT

Ref. No.	Part No.	Description	Amt. Req.
1.	SS7660520SP	Shoulder Screw, for lower main shaft, right	1
2.	660-1062	Spring Washer	1
3.	50374	Spacer, for pulley assembly	1
4.	50321G	Pulley Assembly	1
5.	SS8661012TP	Set Screw	2
6.	50342AX	Sprocket, for lower main shaft	1
7.	SS8660612TP	Screw	2
8.	50342BS	Timing Belt	1
9.	50335AK	Retaining Ring, for ball bearing	1
10.	29476UH	Mainshaft Assembly, lower, right	1
11.	50322AL	Ball Bearing, for lower main shaft	1
12.	50335BB	Retaining Ring	1
13.	50322AG	Lower Main Shaft, right	1
14.	50333A	Coupling, for lower main shafts	1
15.	SS8660612TP	Screw	4
16.	660-934	Oil Seal	1
17.	50622D	Lower Main Shaft, left for plain feed.....	1
17A.	50622E	Lower Main Shaft, left for differential feed	1
18.	SS8660410SP	Screw	2



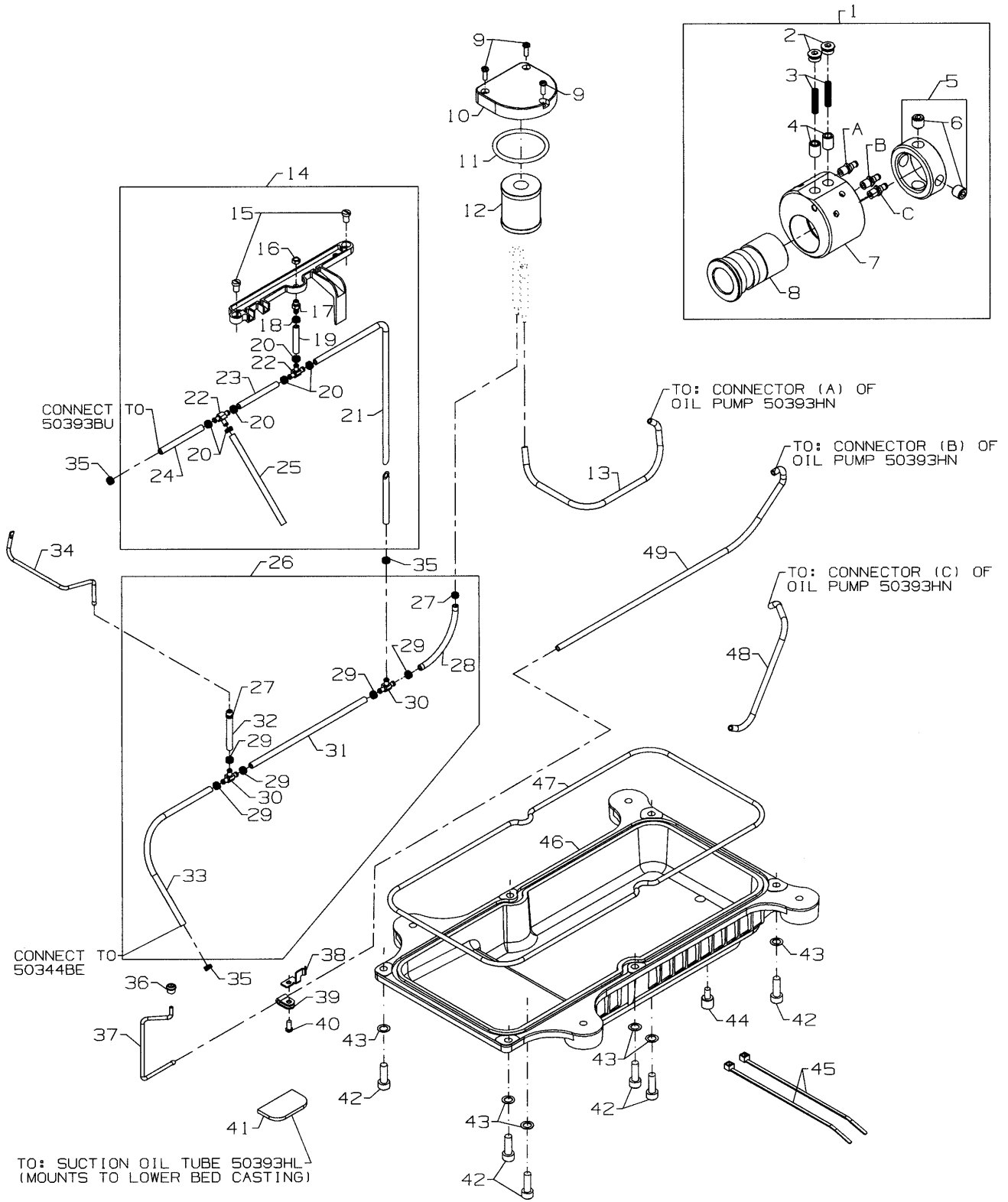

LUBRICATION, OIL TUBING & OIL PUMP

Ref. No.	Part No.	Description	Amt. Req.
1.	50393HN	Oil Pump Assembly, 2-stage	1
2.	SS8660612TP	Screw	2
3.	50332S	Spring, for plunger.....	2
4.	34393D	Plunger	2
5.	50393EX	Collar, for oil pump	1
6.	SS8660612TP	Screw	2
7.	50393GB	Oil Pump Housing, 2 Stage.....	1
8.	50393GD	Oil Pump Housing, 2 Stage.....	1
9.	SS4091015SP	Screw, for oil filter cover.....	3
10.	50393FR	Cover, for oil filter.....	1
11.	50384	"O" Ring, for oil filter cover.....	1
12.	11843208	Oil Filter.....	1
13.	50393FV	Oil Tube, for supply (1)	1
14.	29476XV	Oil Supply Assembly, upper	1
15.	SS7120710SP	Screw, for front upper tube	2
16.	NS6110310SP	Nut	1
17.	SQ1110402MZ	Fitting	1
18.	50393KH	Tube Retaining, spring	1
19.	50393-27	Oil Tube	1
20.	50393KM	Tube Retaining, spring	7
21.	50393-407	Oil Tube	1
22.	13765607	"T" Connector	2
23.	50393-47	Oil Tube	1
24.	50393-51	Oil Tube	1
25.	50393-89	Oil Tube	1
26.	29476UT	Oil Supply Assembly, lower	1
27.	50393KH	Tube Retaining, spring	2
28.	50393-70	Oil Tube	1
29.	50393KM	Tube Retaining, spring	5
30.	13765607	"T" Connector	2
31.	50393-140	Oil Tube	1
32.	50393-40	Oil Tube	1
33.	50393-170	Oil Tube	1
34.	50393KF	Oil Tube	1
35.	50393KM	Tube Retaining, spring	3
36.	50393HR	Plug, for feed chamber	1
37.	50393HL	Oil Tube, for suction	1
38.	50393FS	Oil Tube Holder	1
39.	998-358F	Plastic Clip	1
40.	SS4090815SP	Screw, for oil tube holder	1
41.	50393HK	Felt	1
42.	SS6151812TP	Screw, for oil pan	6
43.	WS0631510KP	Spring Washer	6
44.	22571E	Screw, for oil drain plug	1
45.	RM2871B	Cable Tie	2
46.	50393EB	Oil Pan	1
47.	50384A	"O" Ring	1
48.	50393FT	Oil Tube, for suction	1
49.	50393HJ	Oil Tube, for suction	1



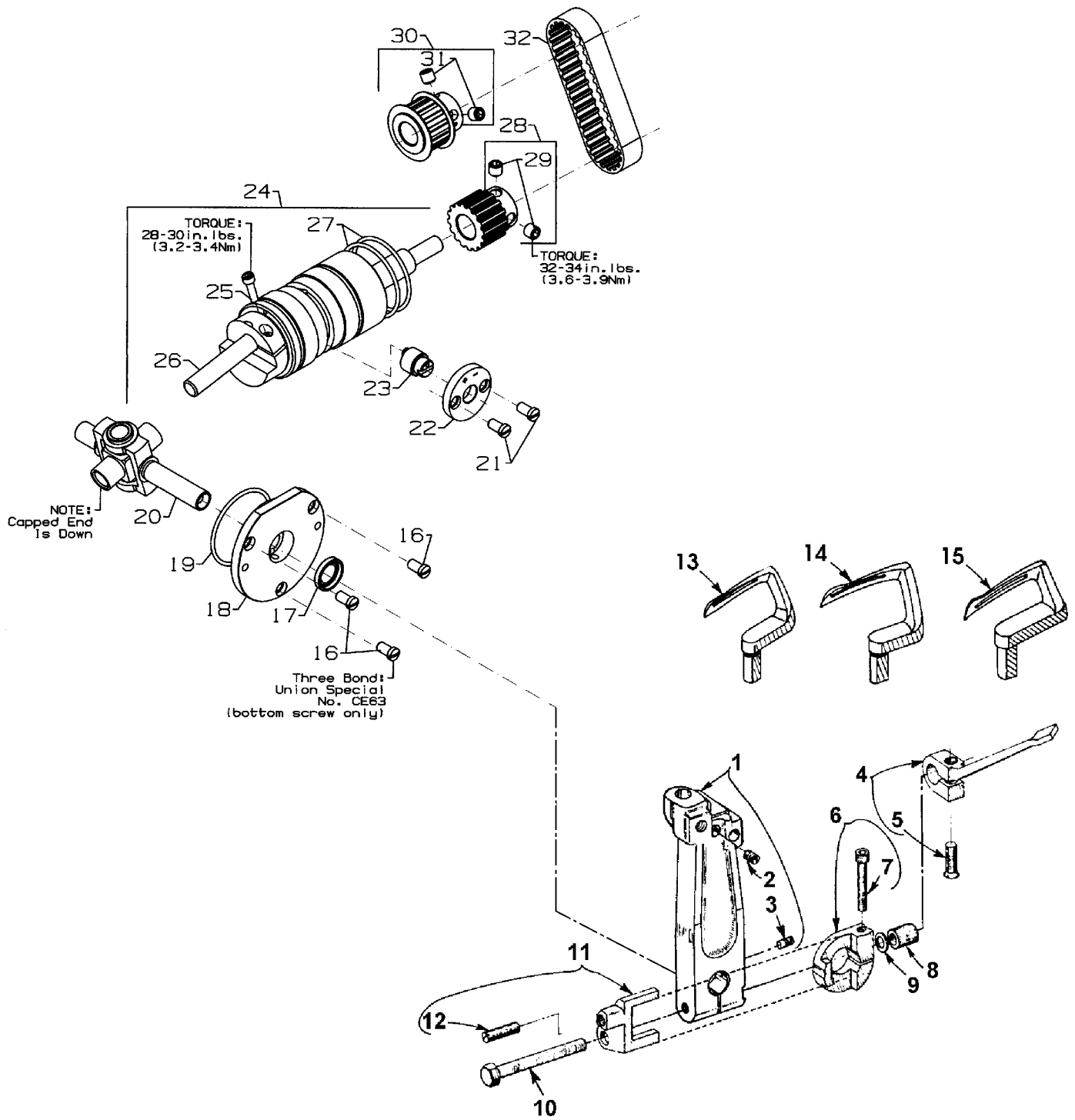

LOOPER DRIVE

Ref. No.	Part No.	Description	Amt. Req.
1.	50313C	Looper Holder	1
2.	22652B10	Screw, for looper holder	1
3.	22565	Screw, for looper holder	2/3
4.	C50041D	Looper Throwout Lever	1
5.	538A	Screw	1
6.	C50041H	Collar, Stop	1
7.	22652J10	Screw	1
8.	C50041E	Lock, Looper Holder	1
9.	53634C	Washer	1
10.	22881C	Screw	1
11.	C50041G	Stop	1
12.	C50041F	Spring, Plunger	1
13.	51909C	Looper, Middle (all gauges)	1
14.	51909D8	Looper, Rear (32 gauge)	1
-	51909D9	Looper, Rear (36 gauge)	1
15.	51908B8	Looper, Front (32 gauge)	1
-	51908B9	Looper, Front (36 gauge)	1
16.	SS7120910SP	Screw, for bearing housing	3
-	CE63	Three Bond Adhesive, (not shown), for screw	-
17.	660-893	Oil Seal, looper	1
18.	50344AM	Bearing Housing Assembly, for looper drive	1
19.	660-455	"O" Ring, for bearing housing assembly	1
20.	50313J	Looper Rocker Assembly	1
21.	SS7120910SP	Screw, for retaining plate	2
22.	50314F	Eccentric Retaining Plate	1
23.	50314E	Looper Avoid Adjusting Eccentric	1
24.	50642	Looper Drive Assembly	1
25.	22653J8	Screw	1
26.	667J33	Crank Pin	1
27.	660-979	"O" Ring	2
28.	50342BJ	Sprocket, for looper driven	1
29.	SS8660612TP	Screw	2
30.	50342BK	Sprocket, for looper drive	1
31.	SS8660612TP	Screw	2
32.	50342BP	Looper Drive Belt	1



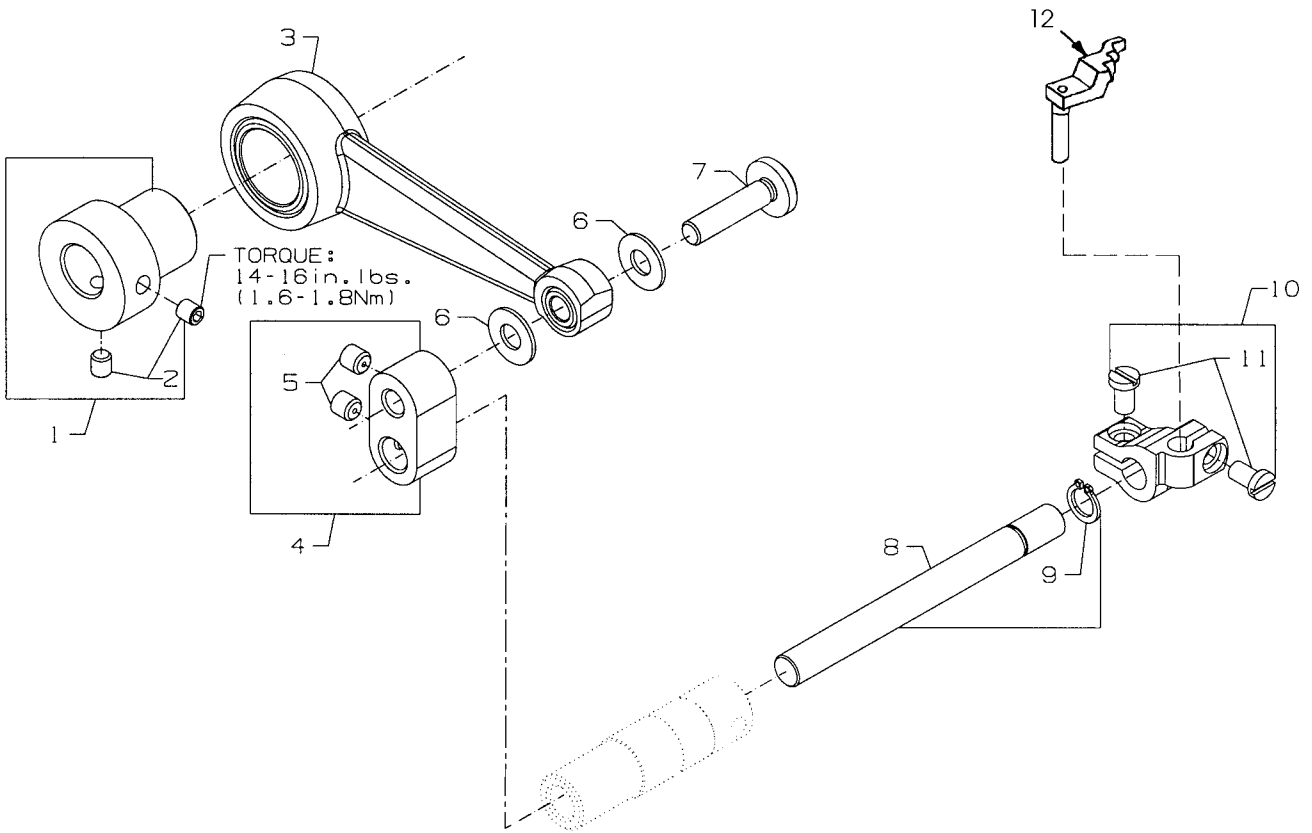

NEEDLE GUARD

Ref. No.	Part No.	Description	Amt. Req.
1.	50373DA	Needle Guard Eccentric	1
2.	SS8110422TP	Screw, for needle guard eccentric	1
3.	50368W	Connecting Rod Assembly, for needle guard	2
4.	50668	Pivot Link	1
5.	SS8110422TP	Screw	1
6.	50368E	Washer	2
7.	50368A	Pivot Pin	2
8.	50622C	Shaft, for needle guard	1
9.	RC0560711KP	Retaining Ring	1
10.	50625	Holder, for needle guard	1
11.	SS6090620SP	Screw	2
12.	C50025E	Needle Guard, Rear (32 Gauge/36 Gauge).....	1



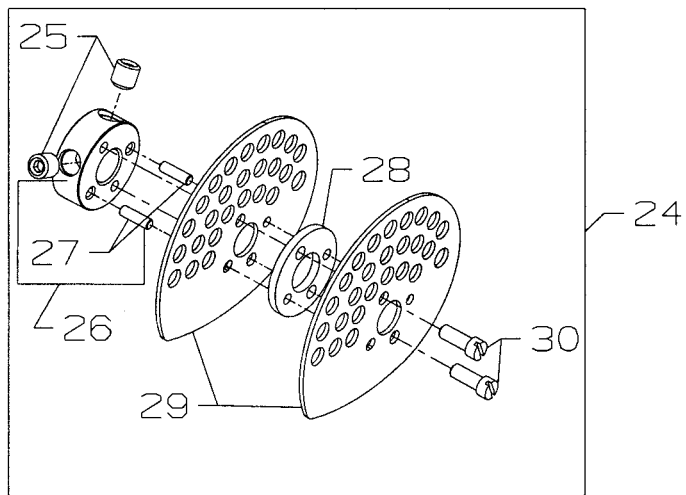
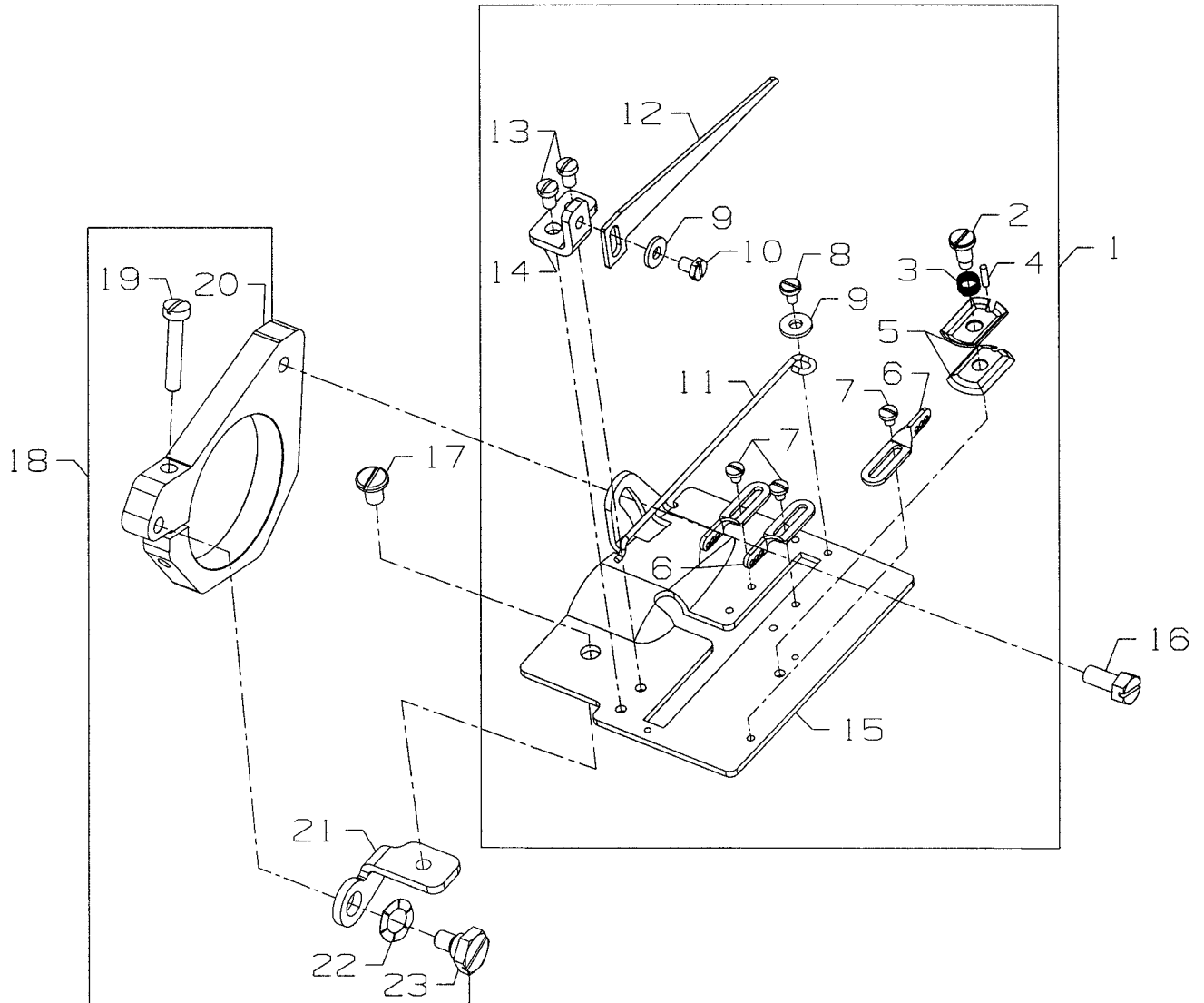

LOOPER THREAD TAKE-UP

Ref. No.	Part No.	Description	Amt. Req.
1.	50657A	Cast-Off Plate Assembly	1
2.	SD0380551SL	Screw	1
3.	50332AC	Tension Spring	1
4.	50347R	Pin	1
5.	51959B	Tension Disc	2
6.	50358H	Eyelet	3
7.	SS7060310SP	Screw	3
8.	SS6060440TP	Screw	1
9.	41358	Washer	2
10.	SS9080410SP	Screw	1
11.	50304H	Strike-Off Wire	1
12.	50604	Retaining Finger	1
13.	SS7080520SP	Screw	2
14.	50383E	Mounting Bracket	1
15.	50357AN	Cast-Off Plate	1
16.	SS9111010SP	Screw, for collar bracket	1
17.	SS6110610TP	Screw, for cast-off holder	1
18.	29476UK	Cast-Off Plate Holder Assembly	1
19.	SS7092110TP	Screw, for collar bracket	1
20.	50383F	Take-up Collar Bracket	1
21.	50304K	Cast-Off Plate Holder	1
22.	WZ0640200KP	Washer	1
23.	SD0630275SP	Shoulder Screw, for cast-off plate holder	1
24.	50623B	Take-up Assembly	1
25.	22894C	Set Screw	2
26.	50323B	Take-up Hub	1
27.	22-348	Pin	2
28.	C50077P	Spacer	1
29.	50323L	Disc, for take-up	2
30.	77B	Screw, for take-up disc	2



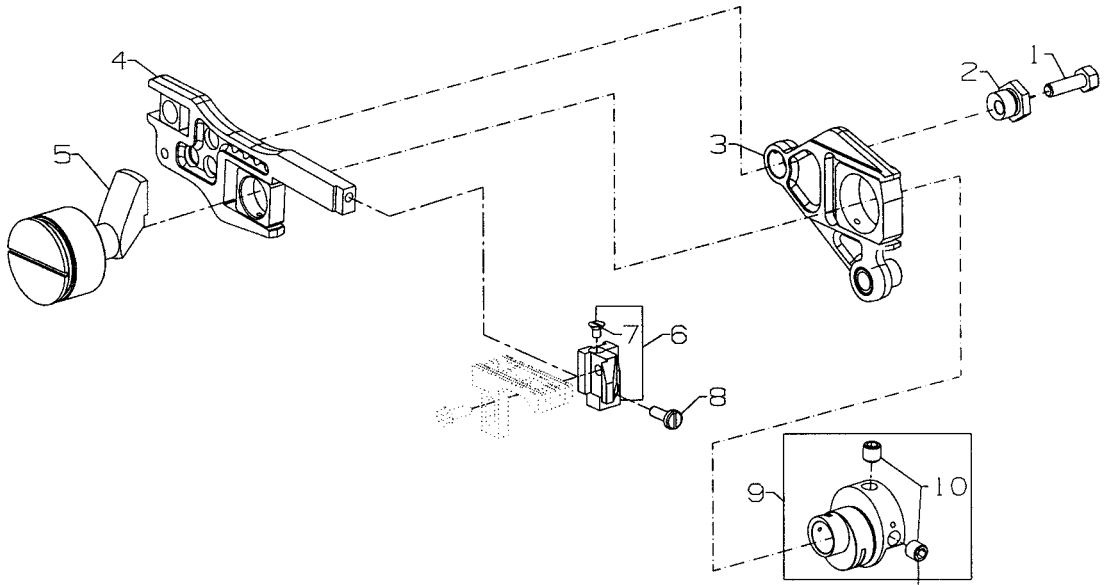

TORQUE:
 32-34 in. lbs.
 (3.6-3.9 Nm)

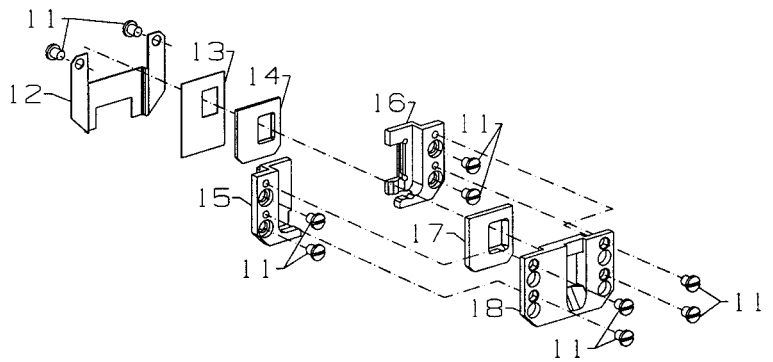

FEED DRIVE MECHANISM
FOR PLAIN FEED

Ref. No.	Part No.	Description	Amt. Req.
1.	18-1432	Screw	1
2.	50334BD	Hex Eccentric Stud	1
3.	29126FB	Drive Fork Assembly, right	1
4.	50634	Feed Bar Assembly	1
5.	50334A	Plain Feed Bar Guide	1
6.	50634E	Feed Dog Holder	1
7.	22637P24	Screw	1
8.	SS7091110TP	Screw	1
9.	50640-29	Feed Eccentric, main	1
10.	SS8660612TP	Screw	2
11.	SS7090530SP	Screw	10
12.	50334Y	Oil Shield	1
13.	50334W	Oil Scraper	1
14.	50634C	Feed Bar Seal	1
15.	50637A	Guide Plate, left, rear	1
16.	50335BA	Guide Plate, right, rear	1
17.	50634D	Feed Bar Seal	1
18.	50637	Guide Plate, front	1



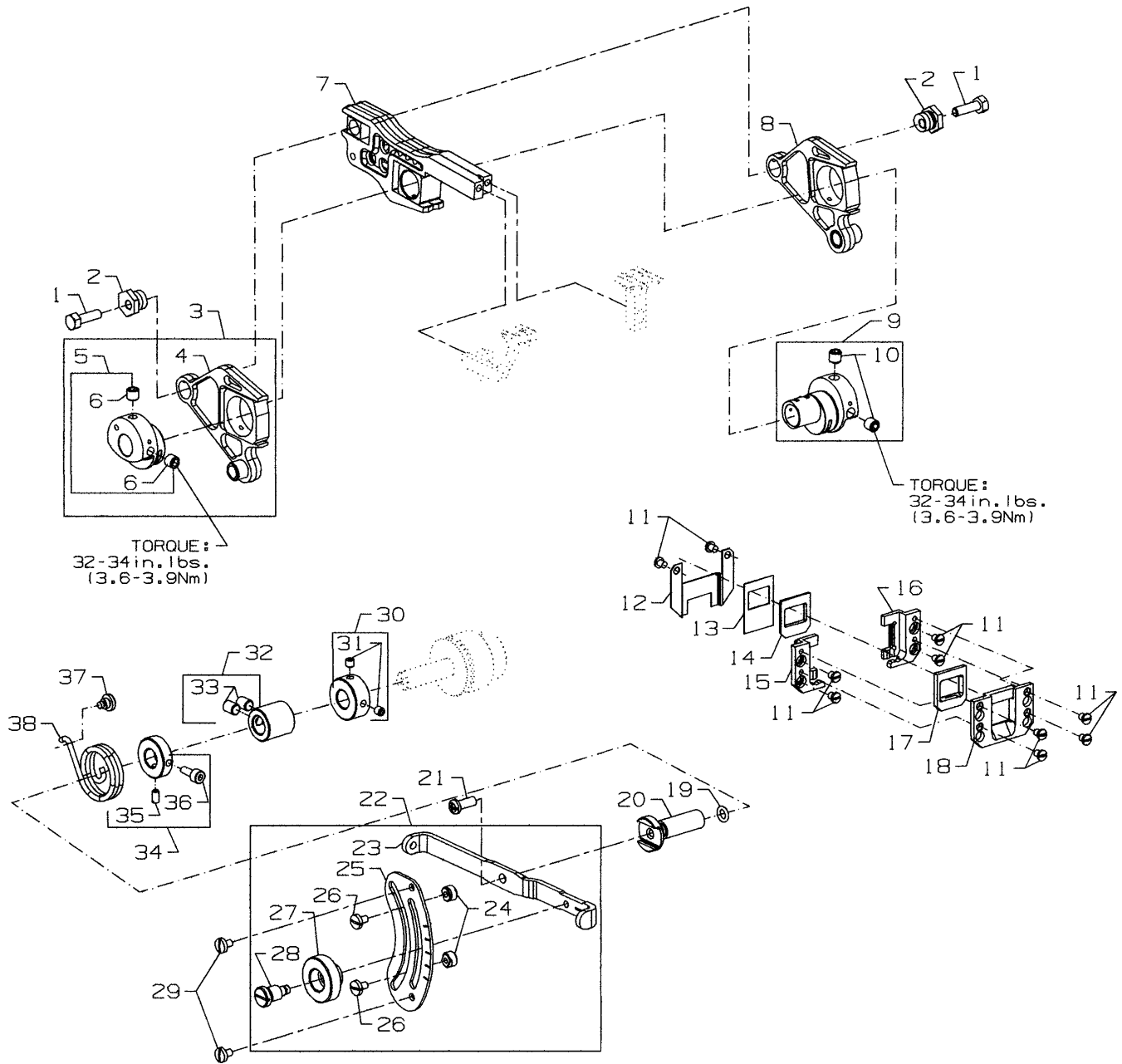

FEED DRIVE MECHANISM FOR DIFFERENTIAL FEED

Ref. No.	Part No.	Description	Amt. Req.
1.	18-1432	Screw	2
2.	50334BD	Hex Eccentric Stud	2
3.	29476VV	Drive Fork Assembly	1
4.	50334AW	Drive Fork Assembly	1
5.	50340F	Feed Eccentric, differential	1
6.	SS8660612TP	Screw	2
7.	50334BE	Feed Bar Assembly	1
8.	50334AX	Drive Fork Assembly, right	1
9.	50640A29	Feed Eccentric, main	1
10.	SS8660612TP	Screw	2
11.	SS7090530SP	Screw	10
12.	50334Y	Oil Shield	1
13.	50334V	Oil Scraper	1
14.	50334BH	Feed Bar Seal	1
15.	50335AM	Guide Plate, left, rear	1
16.	50335BA	Guide Plate, right, rear	1
17.	50334BJ	Feed Bar Seal	1
18.	50335AN	Guide Plate, front	1
19.	660-220	"O" Ring	1
20.	50337J	Stem, for differential feed lever	1
21.	SS4121215SP	Screw, for stem	1
22.	29476YH	Differential Feed Lever Assembly	1
23.	50337H	Differential Feed Lever	1
24.	50337U	Stop	2
25.	50337BD	Plate, for differential feed lever	1
26.	SS7090610SP	Screw	2
27.	B1647704000A	Knob, for differential feed lever	1
28.	50387	Screw	1
29.	SS7090610SP	Screw	2
30.	50337S	Collar	1
31.	SS8110422TP	Screw	2
32.	50337L	Coupling, for differential feed lever	1
33.	SS6110650TP	Screw	2
34.	50337R	Collar, for differential feed lever	1
35.	SS8090710SP	Screw	1
36.	SS6091022TP	Screw	1
37.	SP0550271TP	Screw, for spring	1
38.	50337M	Spring, for differential feed lever	1



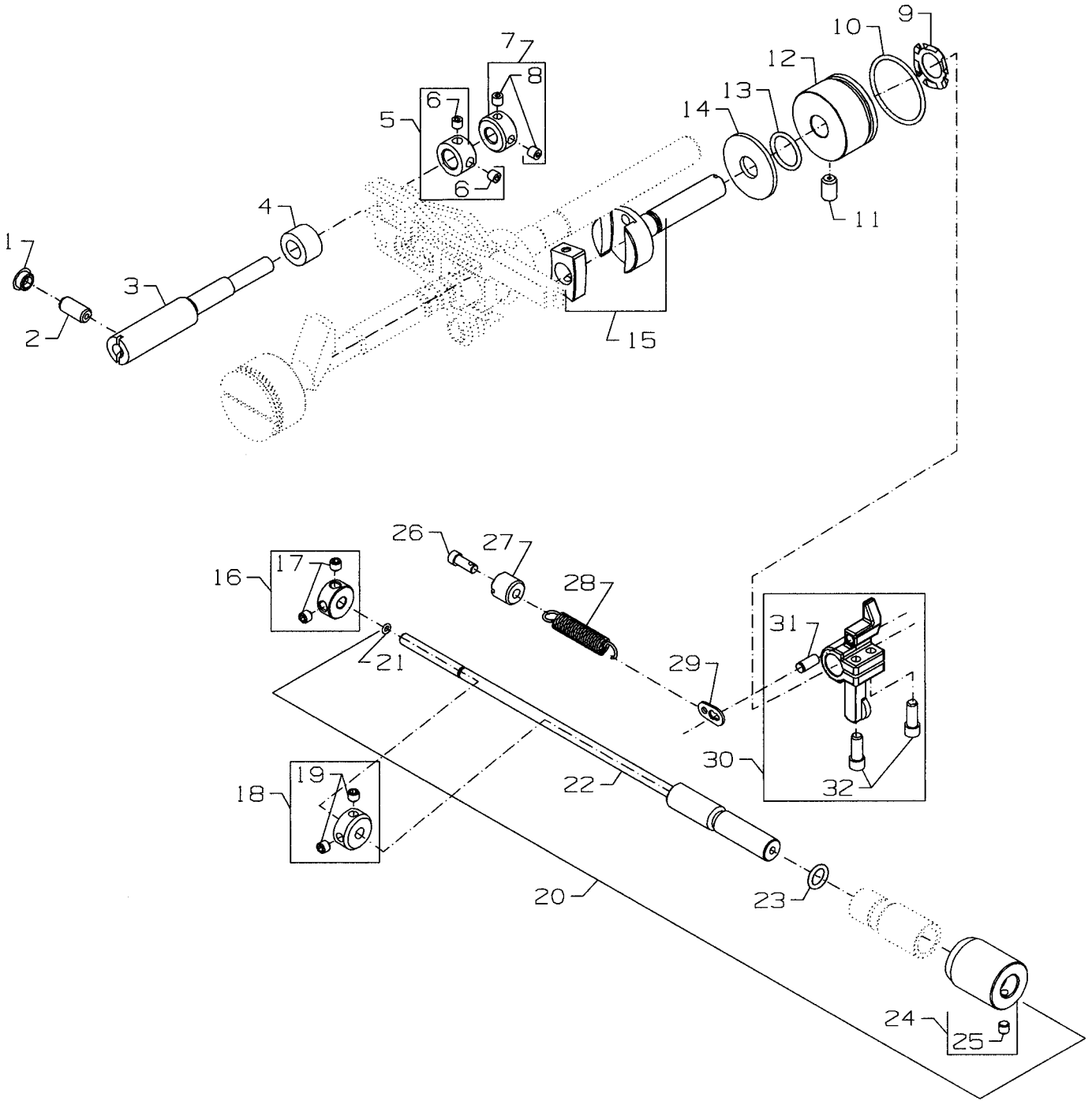

FEED DRIVE MECHANISM
FOR PLAIN FEED

Ref. No.	Part No.	Description	Amt. Req.
1.	TA075404RO	Plug, for eccentric shaft	1
2.	22591A	Screw, for eccentric shaft	1
3.	50334BC	Eccentric Shaft	1
4.	50674	Washer, for eccentric shaft	1
5.	50334BB	Collar, for eccentric shaft	1
6.	SS8110422TP	Screw, for collar	2
7.	50337T	Collar, for eccentric shaft	1
8.	SS8110422TP	Screw, for collar	2
9.	661-96	Spring Washer	1
10.	660-969	"O" Ring, for bushing	1
11.	SS8661012TP	Screw, for bushing	1
12.	35036F	Bushing, for stitch adjusting shaft	1
13.	660-220	"O" Ring, for stitch adjusting shaft	1
14.	35036AZ	Brake Pad	1
15.	50634G	Stitch Adjusting Shaft Assembly	1
16.	50335D	Collar	1
17.	22894P	Screw	2
18.	50333S	Collar	1
19.	22894P	Screw	2
20.	29476UF	Stitch Length Adjusting Rod Assembly	1
21.	660-980	"O" Ring, stitch control shaft	1
22.	50322AR	Shaft, for stitch control	1
23.	660-206	"O" Ring, for stitch control shaft	1
24.	50336Y	Stitch Knob, indicator	1
25.	SS8110422TP	Screw	1
26.	50335	Spring Retainer	1
27.	22714C	Screw, for spring retainer	1
28.	50355	Spring	1
29.	50335A	Spring Holder	1
30.	50336S	Stitch Control Lever	1
31.	661-35	Pin	1
32.	22596H	Screw	2



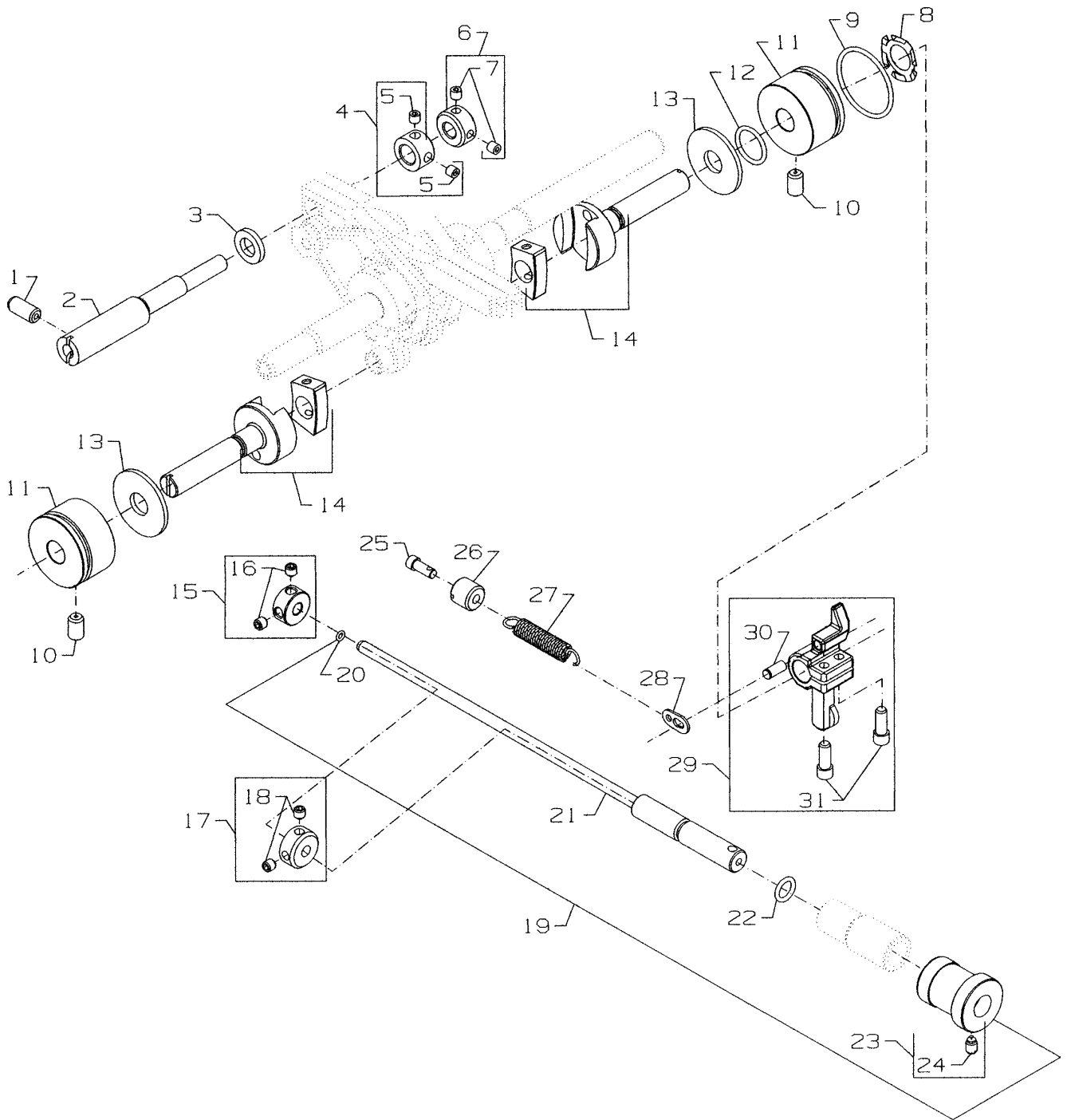

FEED DRIVE MECHANISM FOR DIFFERENTIAL FEED

Ref. No.	Part No.	Description	Amt. Req.
1.	22591A	Screw, for eccentric shaft	1
2.	50334BC	Eccentric Shaft	1
3.	50368AD	Washer, for eccentric shaft	1
4.	50334BB	Collar, for eccentric shaft	1
5.	SS8110422TP	Screw, for collar	2
6.	50337T	Collar, for eccentric shaft	1
7.	SS8110422TP	Screw, for collar	2
8.	661-96	Spring Washer	1
9.	660-969	"O" Ring, for bushing	1
10.	SS8661012TP	Screw, for bushing	2
11.	35036F	Bushing, for stitch adjusting shaft	2
12.	660-220	"O" Ring, for stitch adjusting shaft	1
13.	35036AZ	Brake Pad	2
14.	50634G	Stitch Adjusting Shaft Assembly	2
15.	50335D	Collar	1
16.	22894P	Screw	2
17.	50333S	Collar	1
18.	22894P	Screw	2
19.	29476UF	Stitch Length Adjusting Rod Assembly	1
20.	660-980	"O" Ring, stitch control shaft	1
21.	50322AR	Shaft, for stitch control	1
22.	660-206	"O" Ring, for stitch control shaft	1
23.	50336Y	Stitch Knob, indicator	1
24.	SS8110422TP	Screw	1
25.	50335	Spring Retainer	1
26.	22714C	Screw, for spring retainer	1
27.	50355	Spring	1
28.	50335A	Spring Holder	1
29.	50336S	Stitch Control Lever	1
30.	661-35	Pin	1
31.	22596H	Screw	2



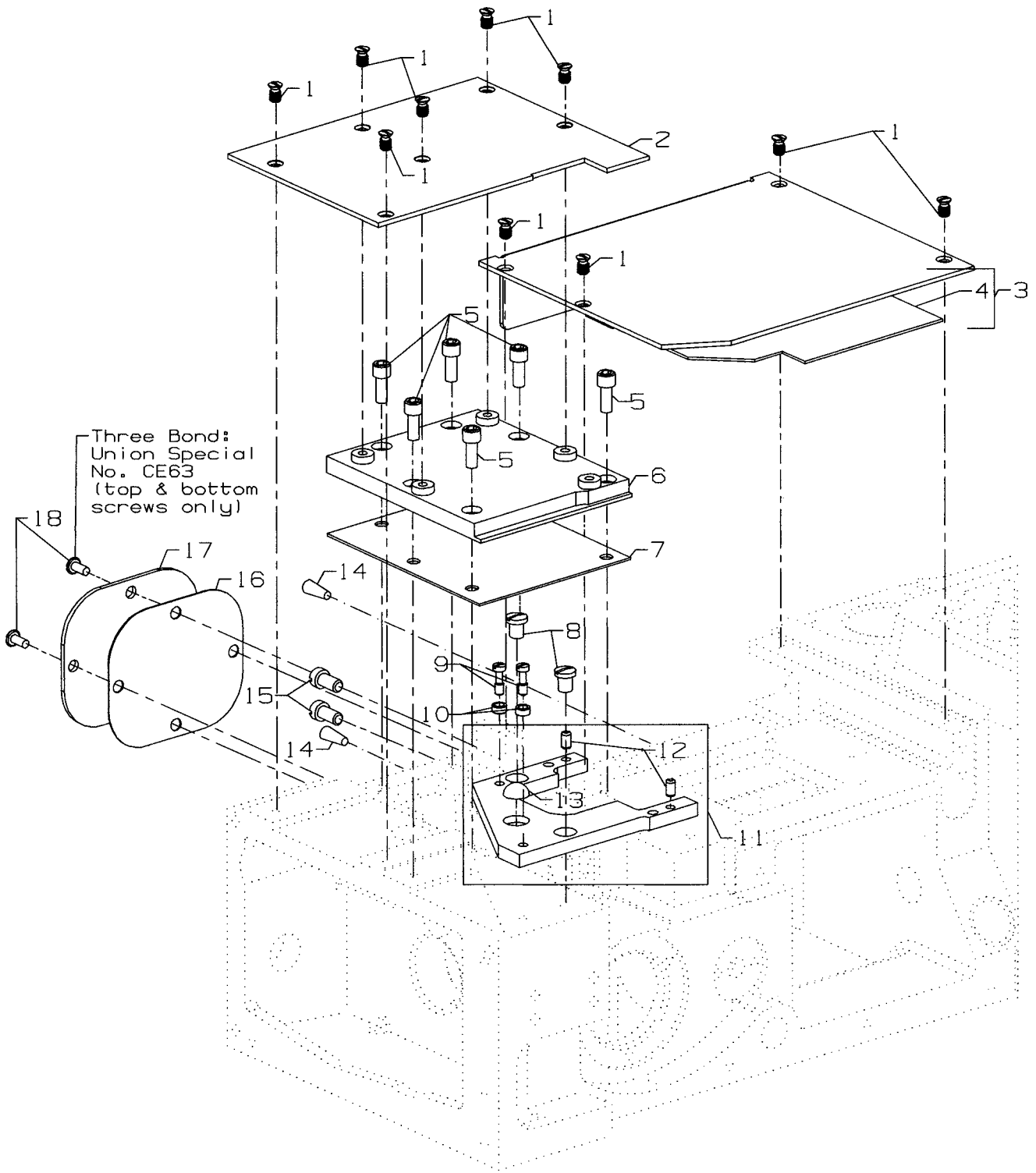

COVERS, LOWER BED

Ref. No.	Part No.	Description	Amt. Req.
1.	18-1448	Screw	11
2.	50601F	Cloth Plate, left	1
3.	50601E	Cloth Plate, right	1
4.	50303B	Acoustic Pad	1
5.	SS6121212TP	Screw, for cover	6
6.	50382CP	Cover, for feed chamber	1
7.	50382CS	Gasket	1
8.	SS7150740SP	Screw	2
9.	22587N	Screw	2
10.	35036AE	Ferrule, Locating	2
11.	50380D	Throat Plate Support, complete	1
12.	51280K	Pin	1
13.	660-939	Rubber Bumper, for Throat Plate Support	1
14.	C067D	Cork	2
15.	22517	Screw, for bed	2
16.	50382CR	Gasket	1
17.	50382CL	Cover, rear, for feed chamber,	1
18.	SS4120615SP	Screw, for cover	2
-	CE63	Three Bond Adhesive, (not shown), for screw	-



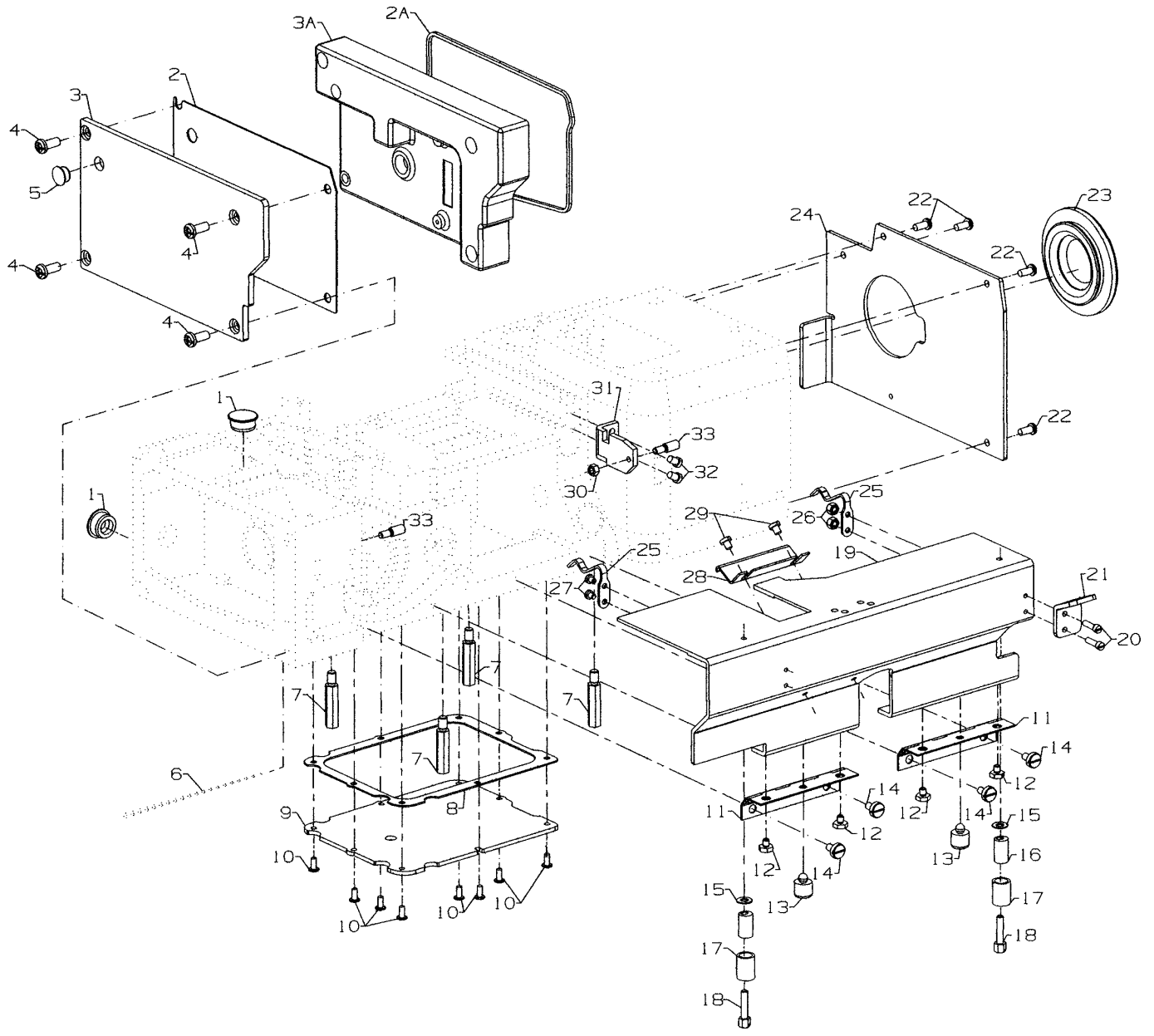

COVERS, LOWER BED

Ref. No.	Part No.	Description	Amt. Req.
1.	50393HB	Plug, for bed	2
2.	50684A	Gasket, for left end cover	1
2A.	50382CM	Quad Ring, for left end cover	1
3.	50682B	Left End Cover	1
3A.	50382KE	Left End Cover	1
4.	SS4151415SP	Screw	4
5.	50393HA	Plug	1
6.	WO3	Oil Wick, for needle guard	1
7.	22841U	Machine Support Stud	4
8.	50383G	Gasket, for chamber cover	1
9.	50382CG	Dry Chamber Cover	1
10.	SS7090850SP	Screw	8
11.	50378S	Hinge	2
12.	SS9110543CP	Screw	4
13.	660-1020	Rubber Bumper	2
14.	SS6120930TP	Screw	4
15.	20	Washer	2
16.	50382T	Stop, for front cover	2
17.	50393W	Rubber Bumper	2
18.	22519J	Screw	2
19.	50682D	Swing Down Cover	1
20.	22729D	Screw	2
21.	50667	Lever	1
22.	SS4121015SP	Screw	4
23.	50393HU	Plug, right end, non-synchronizer	1
24.	50382CJ	Cover, for drive belt	1
25.	50332A	Latch Spring	2
26.	39250J	Nut	2
27.	22513D	Screw	2
28.	50382FP	Latch, looper throw-out safety	1
29.	25CC	Screw	2
30.	35569J	Nut	1
31.	50332B	Support Block	1
32.	SS7120710SP	Screw	2
33.	22799AH	Spring Latch Stud	2



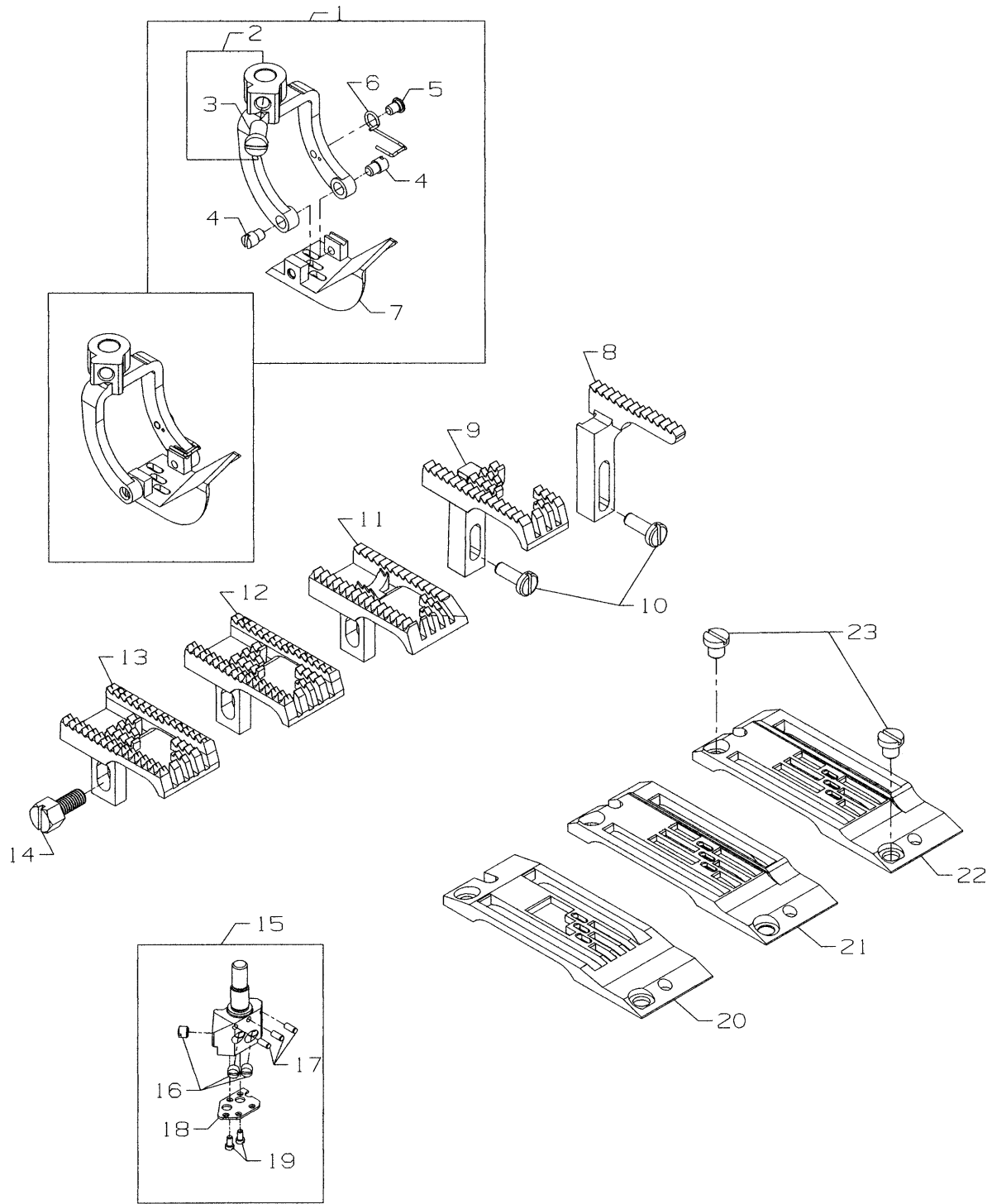

MODEL	NEEDLE HEAD	PRESSER FOOT ASSEMBLY	THROAT PLATE	MAIN FEED DOG	DIFFERENTIAL FEED DOG
FS315L63-3H32CC2PA1	50618B	50620A32	50624R32	50605D	50626D
FS315L63-3H36CC2PA1	50618C	50620A36	50624R36		
FS316L61-3H32CC2PA1	50618B	50620A32	50624A32	50605C36
FS316L61-3H32CC2PA1	50618C	50620A36	50624A36		
FS316L62-3H32CC2PA1	50618B	50620A32	50624B32	50605B
FS316L62-3H36CC2PA1	50618C	50620A36	50624B36		
FS316L63-3H32CC2PA1	50618B	50620-32	50624R32	50605R36
FS316L63-3H36CC2PA1	50618C	50620-36	50624R36		



SEWING PARTS

1.	-----	Presser Foot Assembly, (see Chart)	1
2.	50630C	Presser Foot Fork	1
3.	SS7120910TP	Screw	1
4.	22845A	Screw	2
5.	22599	Screw	1
6.	35830K	Spring	1
7.	35830R8	Presser Foot Bottom, for style FS316L61-3H32CC2PA1	1
-	35830R9	Presser Foot Bottom, for style FS316L61-3H36CC2PA1	1
-	50630B32	Presser Foot Bottom, for style FS316L62-3H32CC2PA1	1
-	50630B36	Presser Foot Bottom, for style FS316L62-3H36CC2PA1	1
-	50630A	Presser Foot Bottom, for style FS316L63-3H32CC2PA1	1
-	50630	Presser Foot Bottom, for style FS316L63-3H36CC2PA1	1
8.	50605D	Feed Dog, (see chart) FS315L63-3H32CC2PA1, FS315L63-3H36CC2PA1.....	1
9.	50626D	Feed Dog, (see chart) FS315L63-3H32CC2PA1, FS315L63-3H36CC2PA1.....	1
10.	SS7091110TP	Screw	2
11.	-----	Feed Dog, (see chart) FS316L61-3H32CC2PA1, FS316L61-3H36CC2PA1.....	1
12.	-----	Feed Dog, (see chart) FS316L62-3H32CC2PA1, FS316L62-3H36CC2PA1 ..	1
13.	-----	Feed Dog, (see chart) FS316L63-3H32CC2PA1, FS316L63-3H36CC2PA1 ..	1
14.	18-1481	Screw	1
15.	-----	Needle Head, (see chart)	1
16.	SS8080310TP	Screw	3
17.	660-1046	Pin	3
18.	50618D	Needle Head Eyelet	1
-	50618A	Needle Head Eyelet	1
19.	22655B7	Screw	2
20.	-----	Throat Plate, for style FS316L61-3H32CC2PA1, FS316L61-3H36CC2PA1	1
21.	-----	Throat Plate, for style FS316L62-3H32CC2PA1, FS316L62-3H36CC2PA1	1
22.	-----	Throat Plate, for style FS316L63-3H32CC2PA1, FS316L63-3H36CC2PA1	1
23.	22570	Screw	2



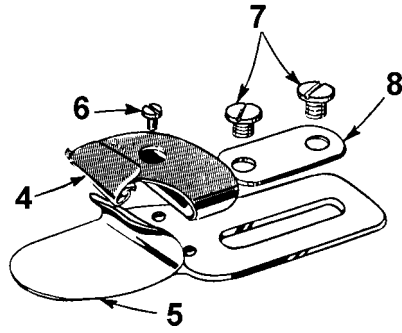
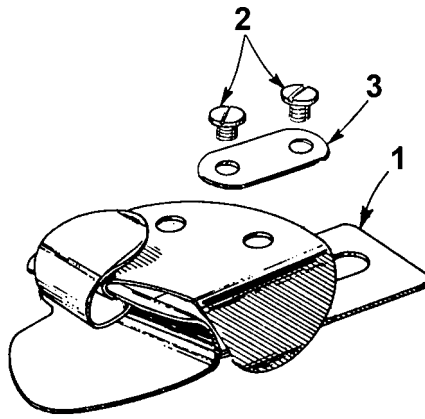

FOLDERS

Ref. No.	Part No.	Description	Amt. Req.
1.	23420S8-1/8	Folder, for Styles, FL53-3H32	1
-	23420S9-1/8	Folder, for Styles, FL53-3H36	1
-	23420U16-3/32	Folder, for Styles, FL52-3H64	1
2.	25C	Screw	2
3.	57864B	Clamp Plate	1
4.	23421U16-3/32	Scroll, For Styles, FL52-3H32	1
-	23421U18-3/32	Scroll, For Styles, FL52-3H36, FL52-2H72	1
5.	23422BZ-3/32	Scroll, Lower, For Styles, FL52-3H32, FL52-3H36	1
-	23422U-3/32	Scroll, Lower, For Styles, FL52-2H72	1
6.	28	Screw	1
7.	25C	Screw	2
8.	57864B	Clamp Plate	1



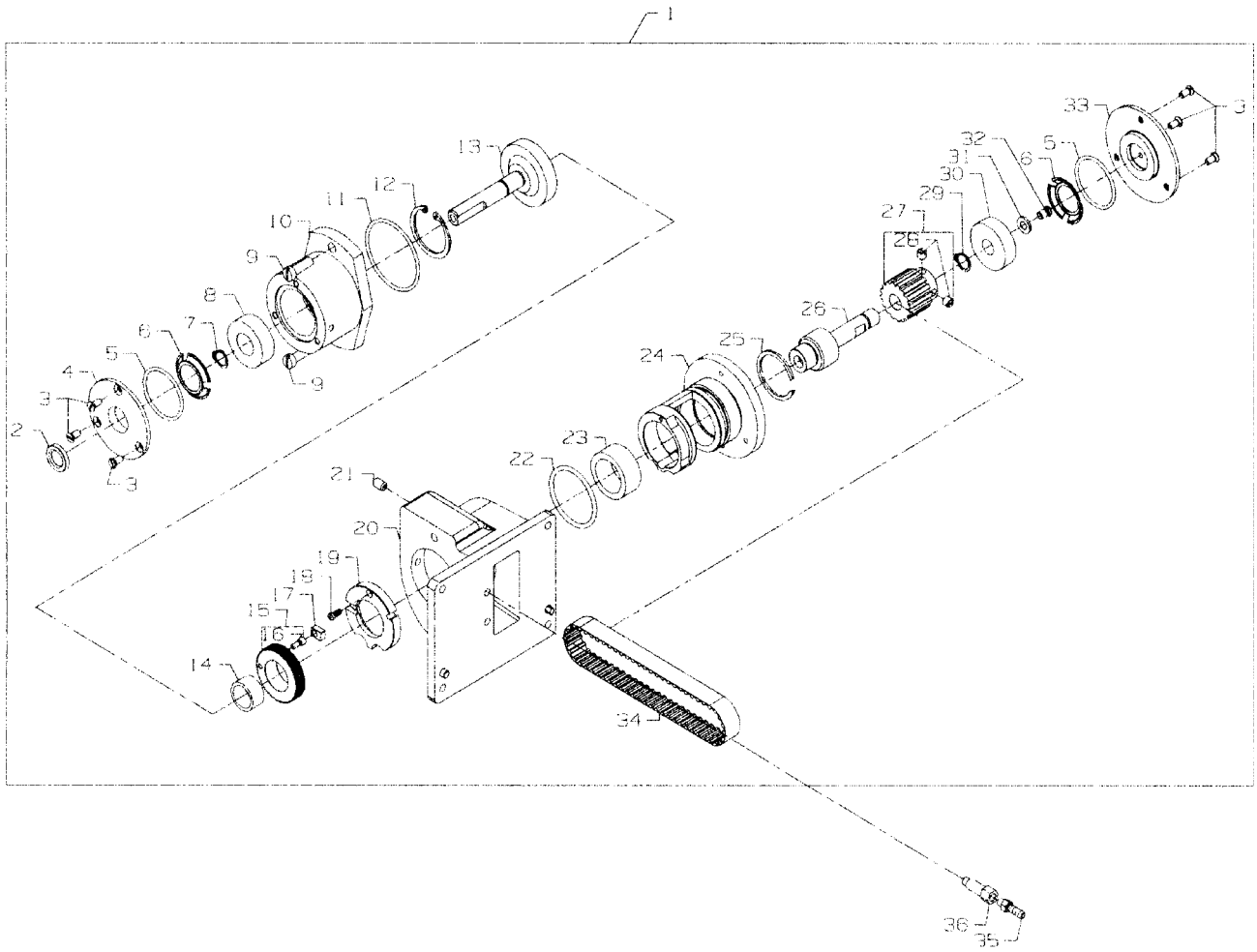

PULLER DRIVE ASSEMBLY

Ref. No.	Part No.	Description	Amt. Req.
1.	29476YG	Puller Drive Assembly	1
2.	660-893	Lip Seal	1
3.	22524	Screw	6
4.	C50082AP	Cover	1
5.	660-886A	"O" Ring	2
6.	660-914	Finger Spring	2
7.	660-918	Retaining Ring	1
8.	660-890	Bearing	1
9.	136	Screw	2
10.	50677A	Bearing Housing	1
11.	660-886B	"O" Ring	1
12.	660-891B	Snap Ring	1
13.	50677U	Internal Gear	1
14.	660-889	Bearing	1
15.	C50078M	Internal Gear	1
16.	C50078K	Pin	1
17.	C50078J	Slide Block	1
18.	22593	Screw	1
19.	C50078N	Guide Ring	1
20.	50677	Puller Drive Housing	1
21.	22894J	Screw	1
22.	660-886C	"O" Ring	1
23.	660-892C	Bearing	1
24.	C50078P	Eccentric Housing	1
25.	661-70A	Snap Ring	1
26.	C50022L	Eccentric Drive Shaft	1
27.	C50042AC16	Sprocket	1
28.	98	Screw	2
29.	660-891C	Snap Ring	1
30.	660-888	Bearing	1
31.	59451F	Washer	1
32.	22574D	Screw	1
33.	C50082AR	Cover	1
34.	C50042AF	Timing Belt	1
35.	671F19	Barb Fitting	1
36.	671F64	Extension Fitting	1



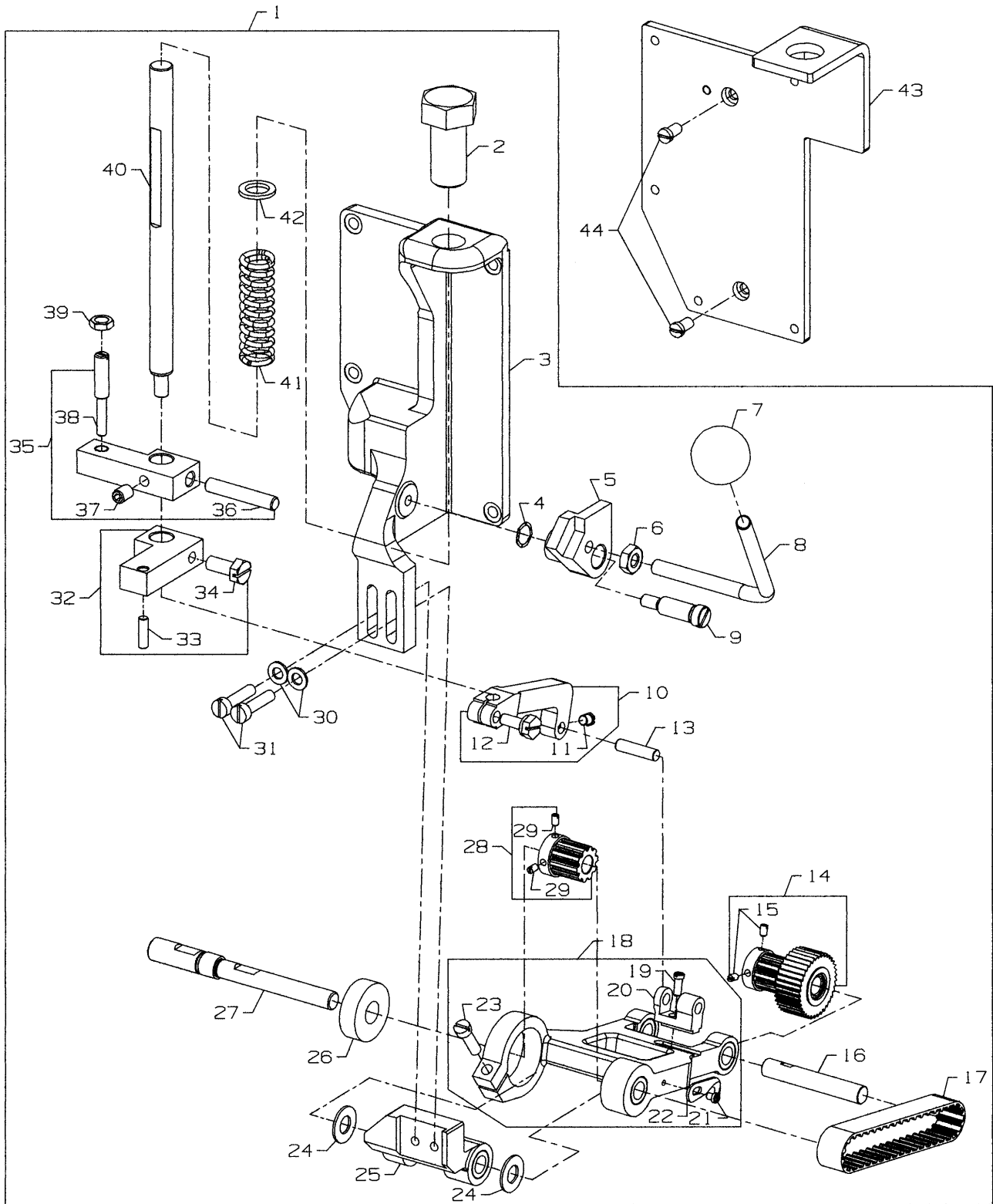

PULLER ASSEMBLY

Ref. No.	Part No.	Description	Amt. Req.
1.	29476YB	Puller Assembly	1
2.	C50077D	Screw, Adjusting	1
3.	50677N	Bracket, Main Puller	1
4.	WZ0850302K0	Washer	1
5.	50677G	Lever, Lifter	1
6.	RM3211-12	Nut	1
7.	50667A	Knob, Ball	1
8.	50677C	Lever, Lifter	1
9.	50695A	Stud Screw	1
10.	50677E	Lever, Roll Pressure	1
11.	SS9110430TP	Screw	1
12.	SS9121210TP	Screw	1
13.	B4107850M00	Pin	1
14.	50677L	Feed Roller	1
-	50677M	Feed Roller, Urethane	1
-	50677R	Feed Roller, Knurled	1
-	50677K	Feed Roller, Reversed Teeth	1
15.	SS8090540SP	Screw	2
16.	50677F	Shaft, Feed Roller	1
17.	C50042AD	Belt	1
18.	50677H	Yoke, Feed Roller	1
19.	SS6080810SP	Screw	1
20.	50635	Link, Connection	1
21.	604	Screw	1
22.	39656A	Knife	1
23.	SS6121610SP	Screw	1
24.	50677S	Washer	2
25.	50638	Block, Mounting	1
26.	660-887	Bearing	1
27.	50677T	Shaft, Feed Roller	1
28.	50642D	Sprocket, Feed Roller	1
29.	SS8090540SP	Screw	2
30.	WP0531000SD	Washer	2
31.	SS6122030SP	Screw	2
32.	50633A	Block, Adjustable	1
33.	11846805	Pin	1
34.	SS9151440CP	Screw	1
35.	50633	Collar, Puller Lifter	1
36.	50647	Pin	1
37.	SS8150822TP	Screw	1
38.	22726Z	Screw	1
39.	NS6150310SP	Nut	1
40.	50677B	Shaft, Puller Lifter	1
41.	28633L	Spring	1
42.	51242L	Washer	1
43.	50662B	Adaptor Plate	1
44.	SS7120910SP	Screw	2



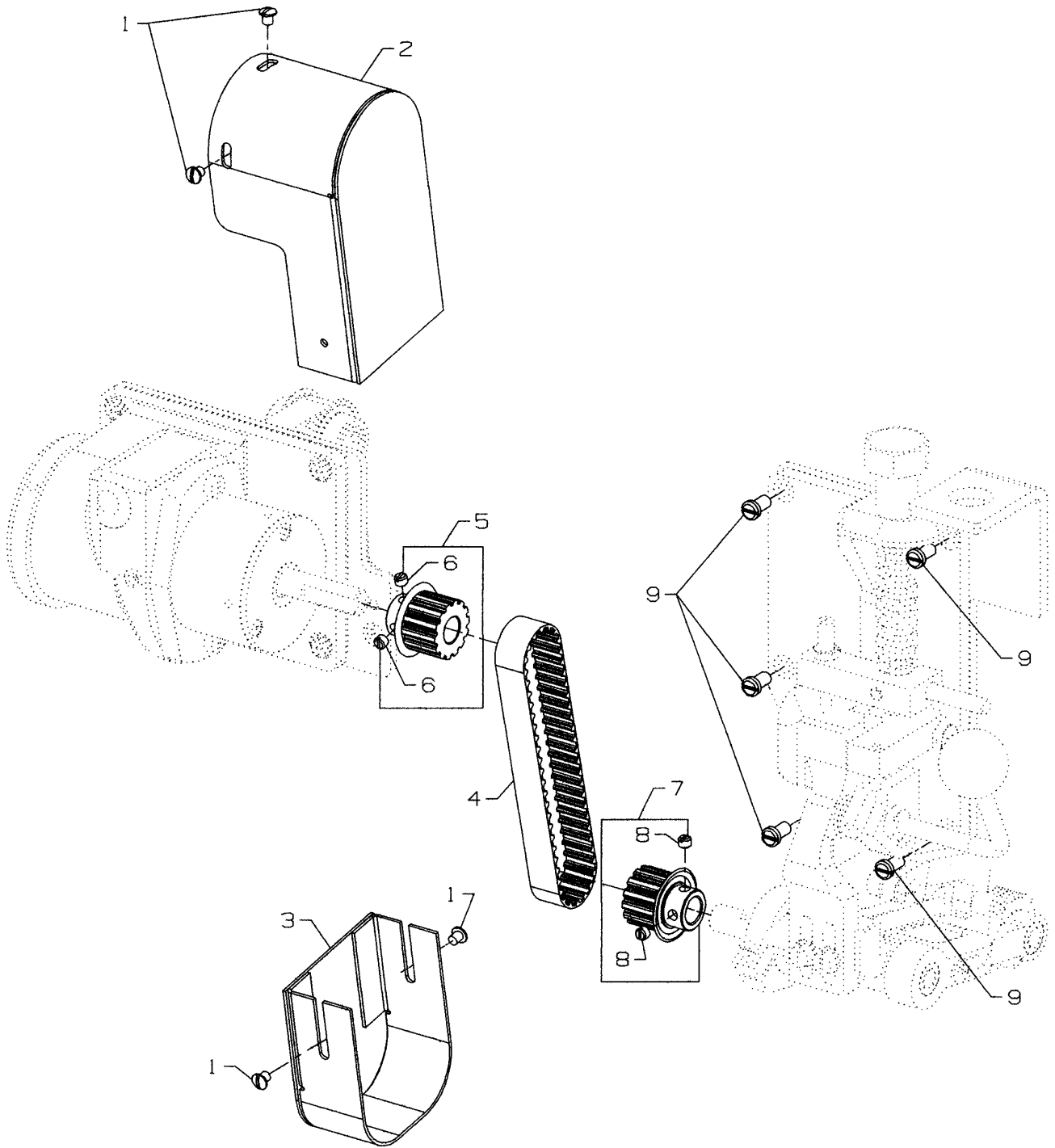

PULLER ASSEMBLY

Ref. No.	Part No.	Description	Amt. Req.
1.	22825	Screw	4
2.	50696C	Belt Guard, Upper	1
3.	50696D	Belt Guard, Lower	1
4.	50642B	Belt	1
*5.	C50042Z14	Sprocket, 14 Teeth	1
* -	C50042Z13	Sprocket, 13 Teeth	1
6.	88B	Screw	2
*7.	C50042Z15	Sprocket, 15 Teeth	1
* -	C50042Z16	Sprocket, 16 Teeth	1
8.	88B	Screw	2
9.	22569C	Screw	5

* See puller sprocket combinations chart (page 21).



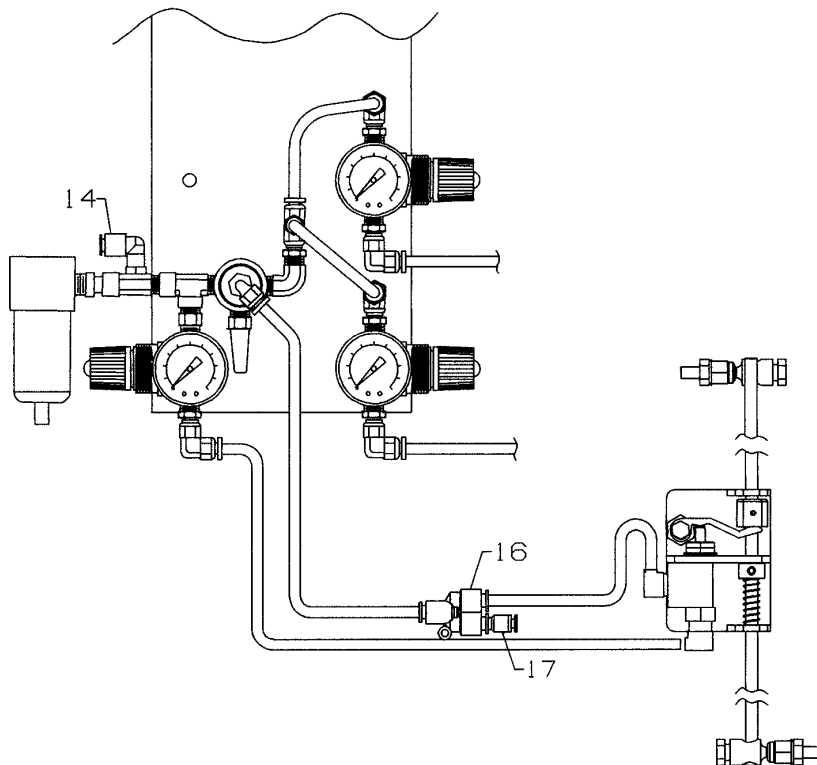
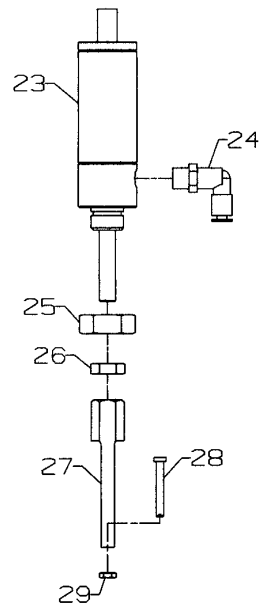
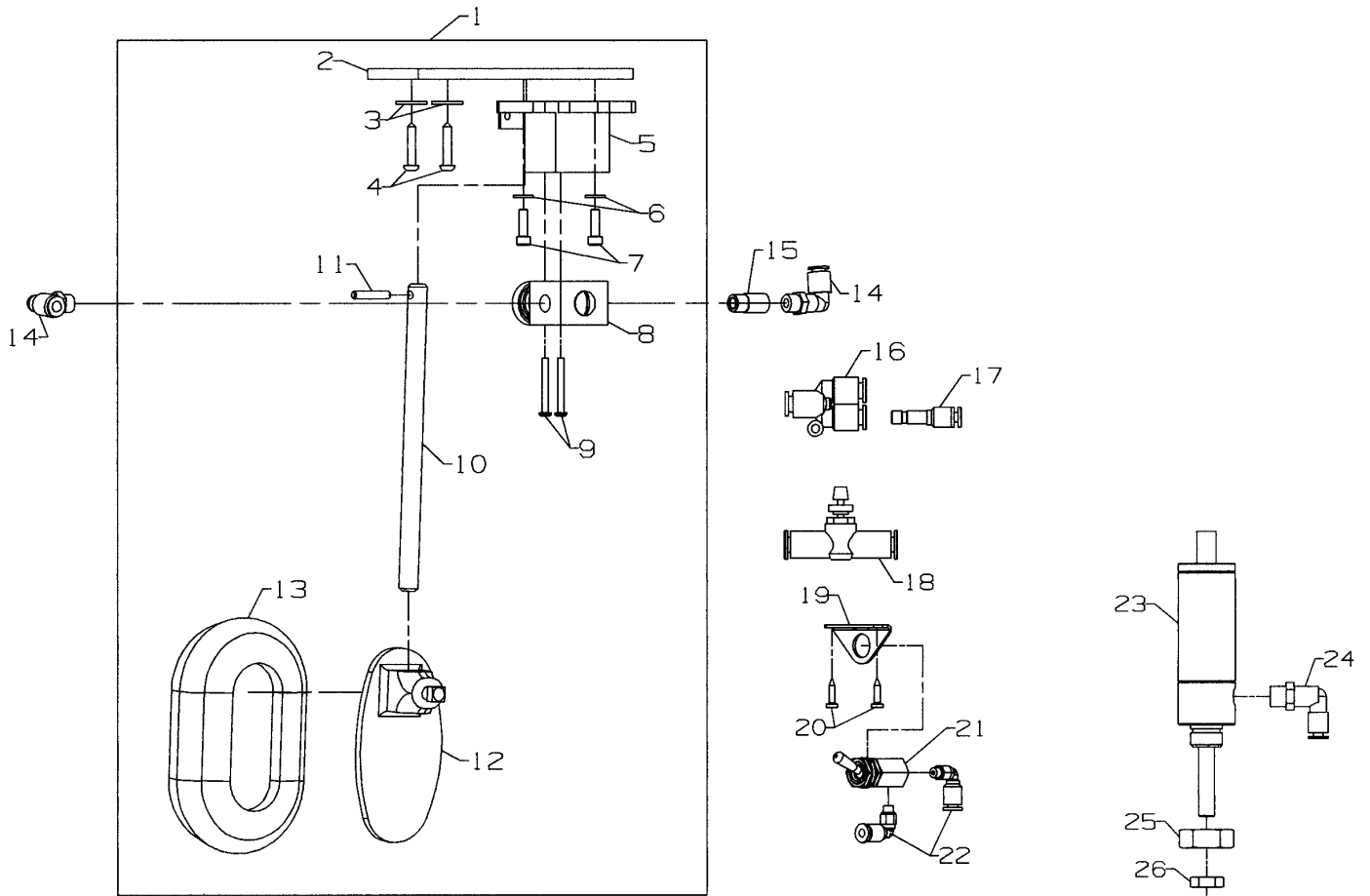

USE IN CONJUNCTION
WITH CATALOG PT9623



MISCELLANEOUS PARTS PA1
(USE WITH CC2 CHAIN CUTTER)

Ref. No.	Part No.	Description	Amt. Req.
1.	29480AWN	Knee Press Fitting	1
2.	50364H	Mounting Plate	1
3.	96902	Washer	2
4.	90561K	Wood Screw	2
5.	AS7-2	Knee Press Base	1
6.	RM3293-5	Flat Washer	2
7.	22653B10	Screw	2
8.	671-85	3-Way Valve Assembly	1
9.	RM4377-4	Screw	2
10.	AS7-1	Knee Press Rod	1
11.	667C16	Dowel Pin	1
12.	AS7-3	Knee Press	1
13.	660-168	Knee Press Pad	1
14.	671F82H	Elbow Fitting	2
15.	660-403	Muffler	1
16.	671F86B	Hose "Y" Connector	2
17.	671F82H	5/32" To 1/4" T Reducer	2
18.	671-196	Flow Control	1
19.	999-160	Bracket	1
20.	90561E	Wood Screw	2
21.	671-66	Toggle Valve	1
22.	671F82F	Male Elbow	2
23.	660-397	Air Cylinder	1
24.	671F82C	Male Elbow	2
25.	99327	Nut	1
26.	21233FB	Nut	1
27.	99590Q	Cylinder Rod	1
28.	99372B	Screw	1
29.	41071G	Nut	1



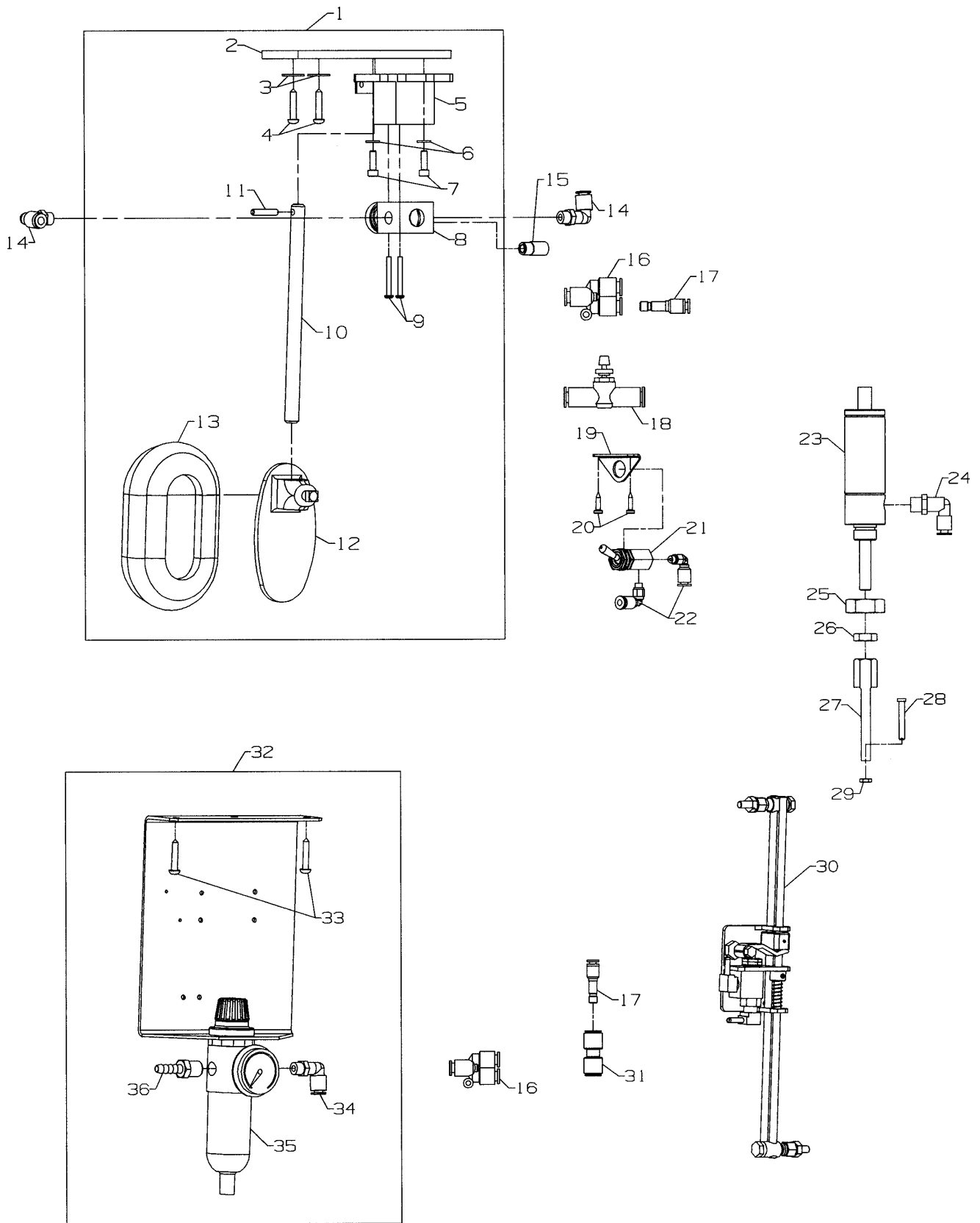

MISCELLANEOUS PARTS PA1A
(USE WITHOUT CC2 CHAIN CUTTER)

Ref. No.	Part No.	Description	Amt. Req.
1.	29480AWN	Knee Press Fitting	1
2.	50364H	Mounting Plate	1
3.	96902	Washer	2
4.	90561K	Wood Screw	2
5.	AS7-2	Knee Press Base	1
6.	RM3293-5	Flat Washer	2
7.	22653B10	Screw	2
8.	671-85	3-Way Valve Assembly	1
9.	RM4377-4	Screw	2
10.	AS7-1	Knee Press Rod	1
11.	667C16	Dowel Pin	1
12.	AS7-3	Knee Press	1
13.	660-168	Knee Press Pad	1
14.	671F82H	Elbow Fitting	2
15.	660-403	Muffler	1
16.	671F86B	Hose "Y" Connector	2
17.	671F82H	5/32" To 1/4" T Reducer	2
18.	671-196	Flow Control	1
19.	999-160	Bracket	1
20.	90561E	Wood Screw	2
21.	671-66	Toggle Valve	1
22.	671F82F	Male Elbow	2
23.	660-397	Air Cylinder	1
24.	671F82C	Male Elbow	2
25.	99327	Nut	1
26.	21233FB	Nut	1
27.	99590Q	Cylinder Rod	1
28.	99372B	Screw	1
29.	41071G	Nut	1
30.	29480ARN	Treadle Assembly	1
31.	671F86D	Fitting	1
32.	29480ASU	Filter Regulator Gauge Kit	1
33.	90561K	Wood Screw	2
34.	671F81A	Elbow Fitting	1
35.	671D42	Combination Filter Regulator	1
36.	671F88	Barb Fitting	1



TUBING PA1 WITH CHAIN CUTTER

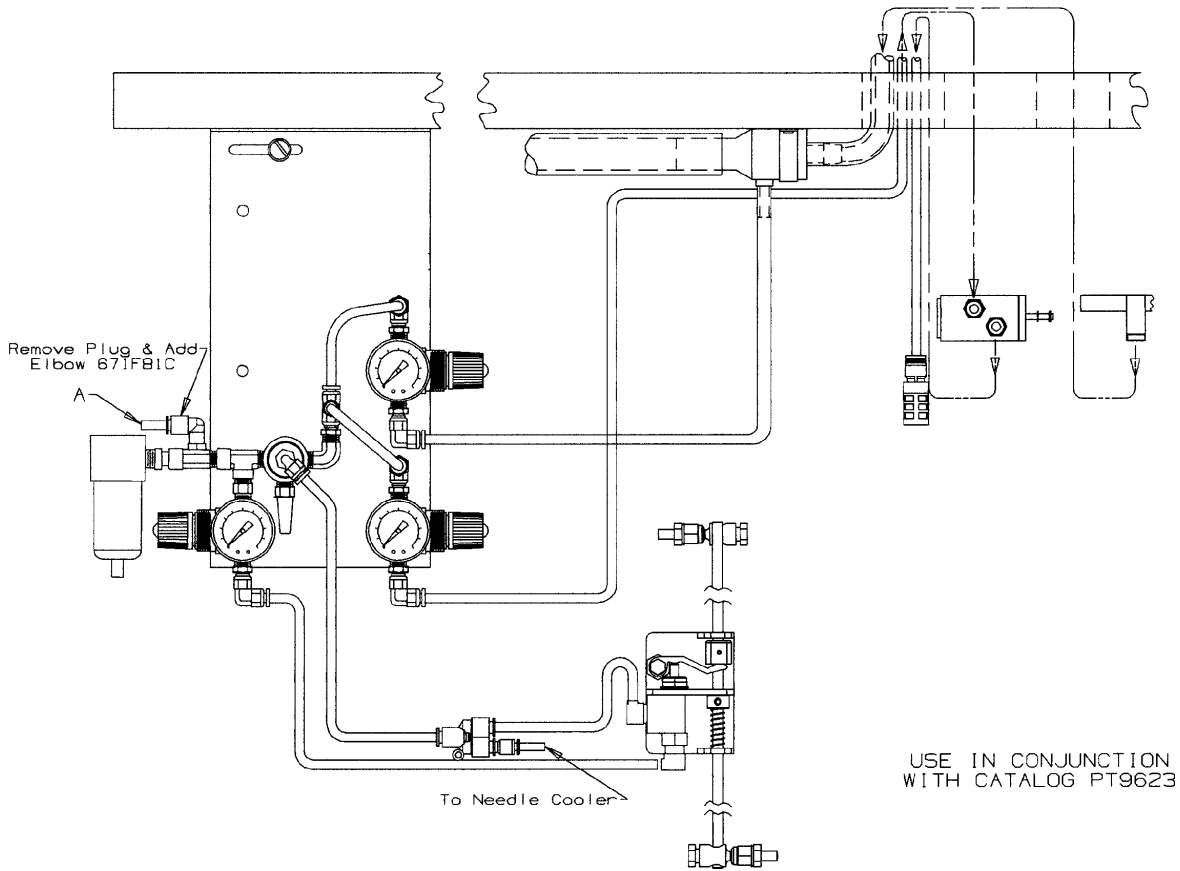
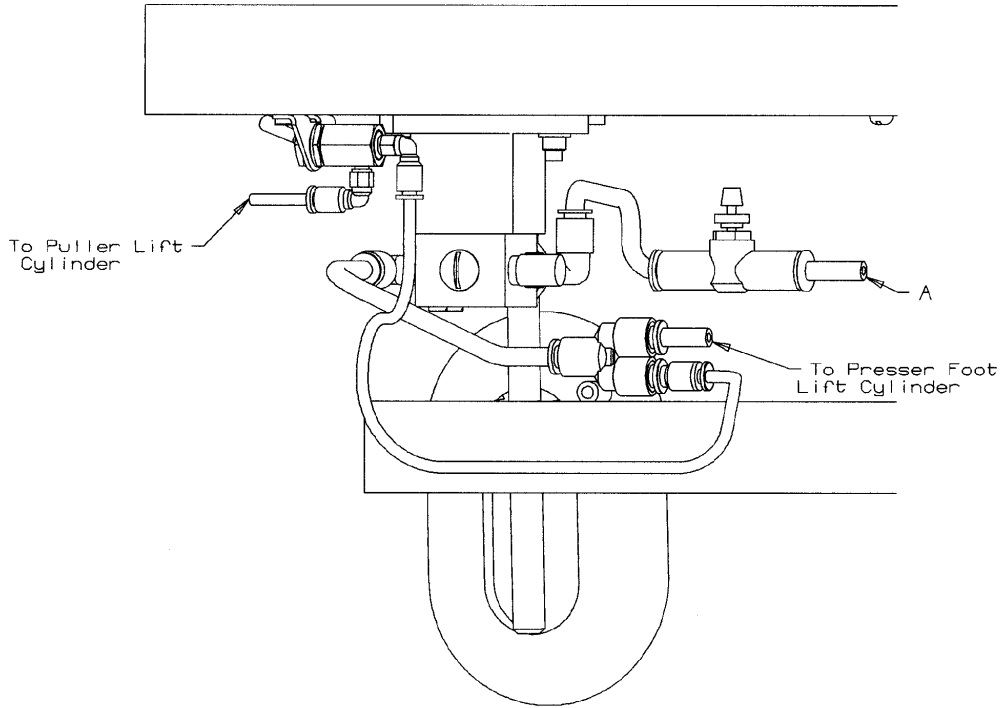

USE IN CONJUNCTION
WITH CATALOG PT9623



TUBING PA1A
WITHOUT CHAIN CUTTER

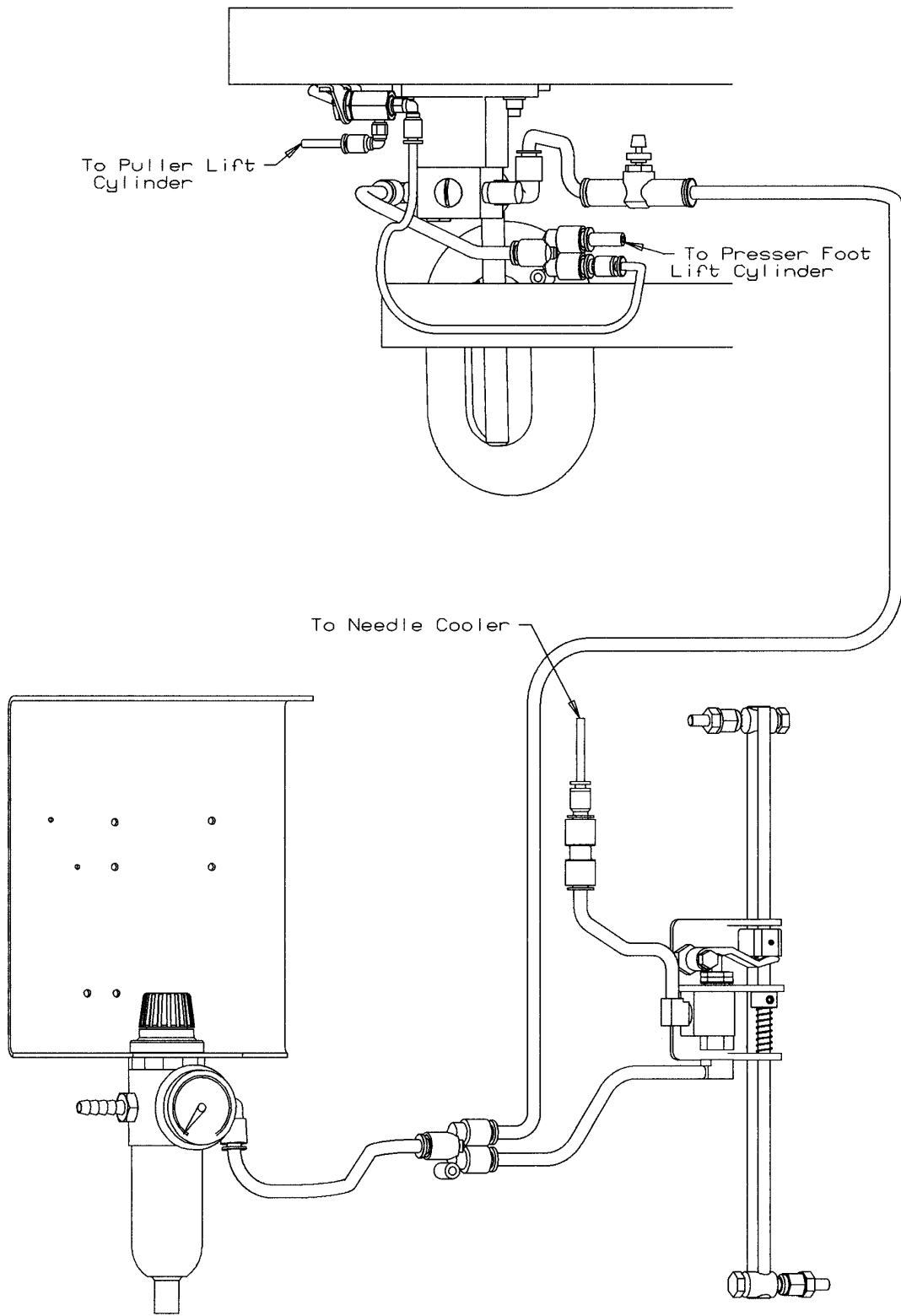

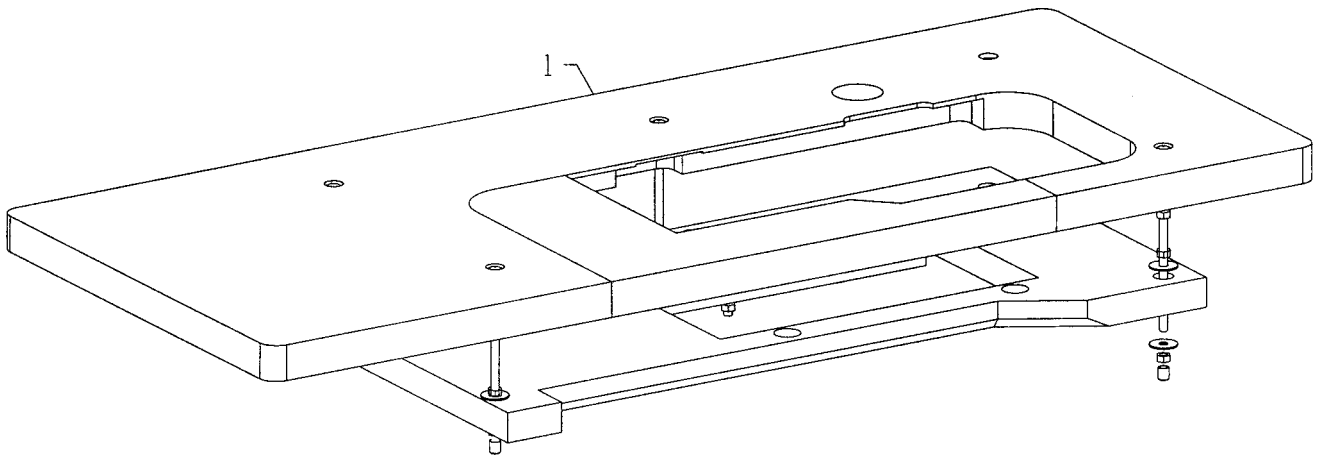

TABLING
(EXTRA SEND CHARGE)

Ref. No.	Part No.	Description	Amt. Req.
1.	21317AAH48	Table Board, for plain feed machines	1



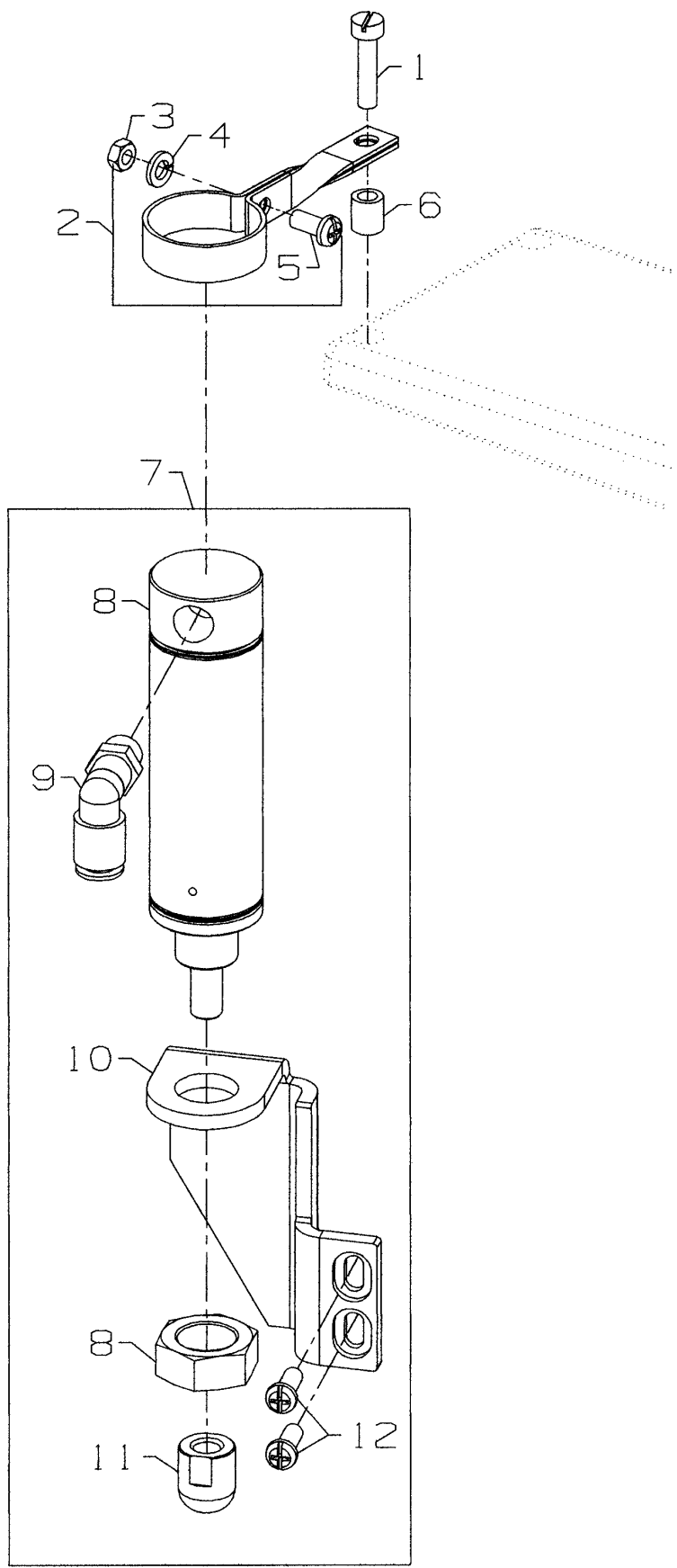

PRESSER FOOT LIFTER

Ref. No.	Part No.	Description	Amt. Req.
1.	SS6122030SP	Screw	1
2.	50383AR	Cylinder Support Bracket	1
3.	NS6120310SP	Nut	1
4.	WS0510002KP	Washer	1
5.	SS4121015SP	Screw	1
6.	50374K	Spacer	1
7.	29480AXJ	Presser Foot Lifter Assembly	1
8.	671A360	Air Cylinder	1
9.	671F81C	Fitting	1
10.	50383AF	Bracket	1
11.	660-1099	Air Cylinder Cap	1
12.	SS4121215SP	Screw	2



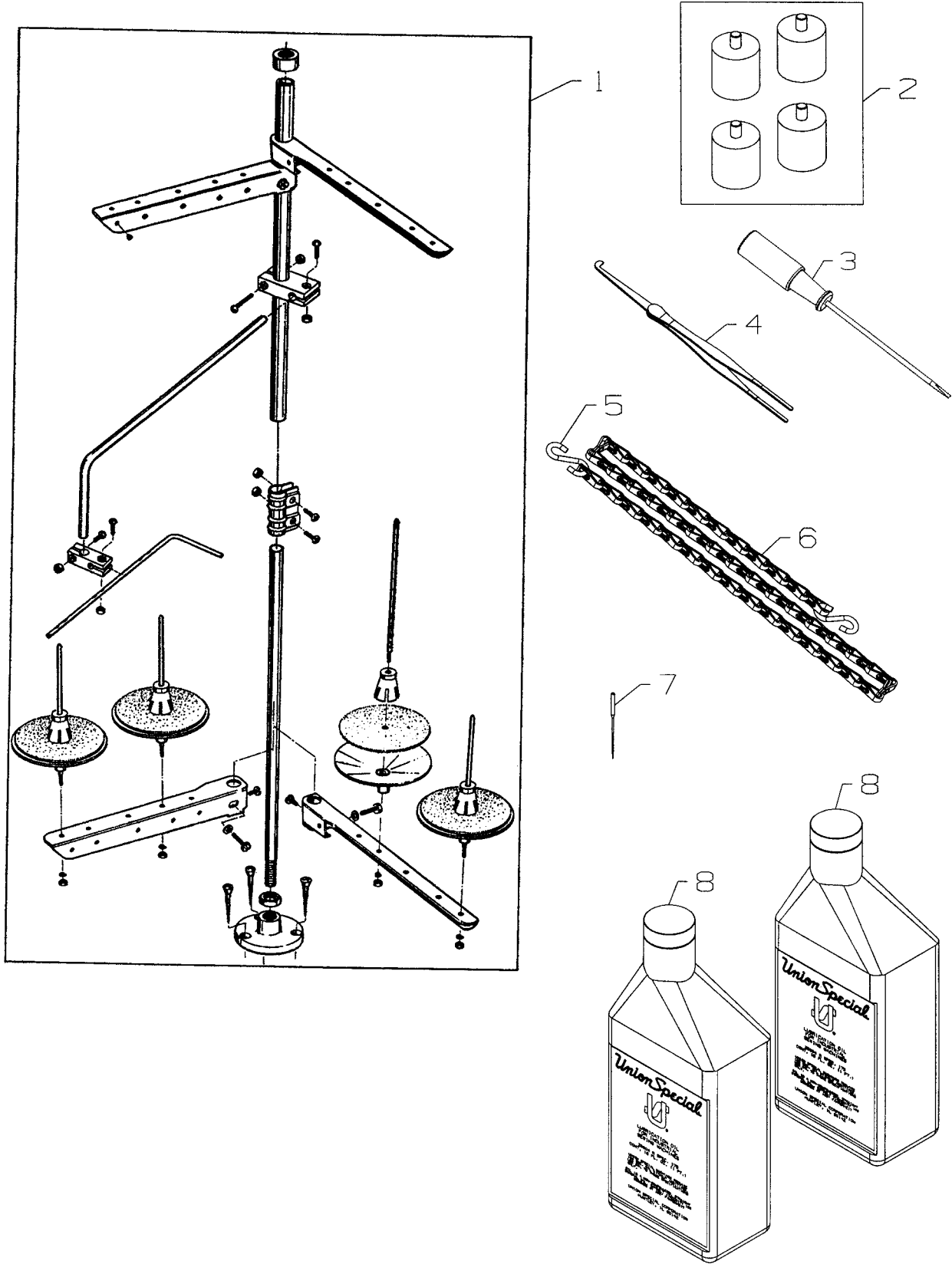

ACCESSORIES

Ref. No.	Part No.	Description	Amt. Req.
1.	21101W4	Thread Stand (2 Needle)	1
-	21101W6	Thread Stand (3 Needle)	1
2.	35095B	Isolator	4
3.	21201A	Screw Driver, for needle head	1
4.	660-240	Thread Tweezer	1
5.	660-264	S-Hook	2
6.	421D34	Chain	1
7.	128GAS140/054	Needles	10
8.	28604R	Oil, (1 pint)	2



NUMERICAL INDEX OF PARTS

Part No.	Page No.	Part No.	Page No.	Part No.	Page No.	Part No.	Page No.	Part No.	Page No.
11071602	33	23421U16-3/32	61	50330CZ	23	50354F	25	50393-140	39
11071701	33	23421U18-3/32	61	50332A	57	50355	51, 53	50393-170	39
11550100	31	23422BZ-3/32	61	50332AC	45	50355AM	25	50393-27	39
11843208	39	23422U-3/32	61	50332B	57	50355AN	25	50393-40	39
11846805	65	25C	61	50332S	39	50355AR	33	50393-407	39
128GAS140/054	79	25CC	57	50332U	23	50357AE	29	50393-47	39
136	63	28	61	50332V	33	50357AN	45	50393-51	39
13765607	39	28604R	79	50333A	37	50357AS	29	50393-70	39
18-1432	47, 49	28633L	65	50333S	51, 53	50357V	29	50393-89	39
18-1448	55	29126FB	47	50334A	47	50357Y	29	50393EB	39
18-1481	59	29476TC	25	50334AW	49	50358H	45	50393EU	35
20	57	29476TT	33	50334AX	49	50358V	29	50393EW	35
21101W4	79	29476UF	51, 53	50334BB	51, 53	50358W	29	50393EX	39
21101W6	79	29476UH	37	50334BC	51, 53	50358X	25	50393EY	23
21201A	79	29476UK	45	50334BD	47, 49	50364H	69, 71	50393FR	39
21233FB	69, 71	29476UT	39	50334BE	49	50366	29	50393FS	39
21237DR	35	29476VN	25	50334BH	49	50366B	29	50393FT	39
21237ET	35	29476VV	49	50334BJ	49	50368A	43	50393FU	23
21237EU	35	29476XV	39	50334V	49	50368AD	53	50393FV	39
21237EV	35	29476YB	65	50334W	47	50368E	43	50393GB	39
21317AAH48	75	29476YD	33	50334Y	47, 49	50368W	43	50393GD	39
22-348	45	29476YG	63	50335	51, 53	50370F	29	50393GE	23
22513D	57	29476YH	49	50335A	51, 53	50373DA	43	50393HA	57
22517	55	29480ARN	71	50335AG	33	50374	37	50393HB	35, 57
22517B	35	29480ASU	71	50335AH	33	50374K	77	50393HH	29
22519J	57	29480AWN	69, 71	50335AK	37	50378S	57	50393HJ	39
22524	63	29480AXJ	77	50335AM	49	50380D	55	50393HK	39
22565	41	34393D	39	50335AN	49	50381	33	50393HL	39
22569B	35	35036AE	55	50335BA	47, 49	50381B	33	50393HN	39
22569C	67	35036AZ	51, 53	50335BB	37	50381E	23	50393HR	39
22570	59	35036BS	23	50335BD	27	50381F	33	50393HU	57
22571E	39	35036F	51, 53	50335D	51, 53	50381G	33	50393JP	25
22571L	23	35095B	79	50336S	51, 53	50382CG	57	50393JW	25
22574D	63	35569J	57	50336Y	51, 53	50382CJ	57	50393JZ	25
22587N	55	35830K	59	50337BD	49	50382CL	55	50393KF	39
22591A	51, 53	35830R8	59	50337H	49	50382CM	57	50393KH	39
22593	63	35830R9	59	50337J	49	50382CP	55	50393KM	39
22596H	51, 53	36271A	29	50337L	49	50382CR	55	50393W	57
22599	59	39250J	57	50337M	49	50382CS	55	50601E	55
22637P24	47	39656A	65	50337R	49	50382FP	57	50601F	55
22652B10	41	41071G	69, 71	50337S	49	50382FW	35	50604	45
22652J10	41	41358	45	50337T	51, 53	50382FX	35	50605D	59
22653B10	69, 71	421D34	79	50337U	49	50382FY	35	50618A	59
22653J8	41	50303B	55	50338	25	50382FZ	35	50618D	59
22655B7	59	50304H	45	50338A	25	50382GA	35	50622C	43
22714C	51, 53	50304K	45	50340F	49	50382GM	35	50622D	37
22726Z	65	50313C	41	50342AX	37	50382KE	57	50622E	37
22729D	57	50313J	41	50342BE	27	50382T	57	50623B	45
22784N	35	50314E	41	50342BJ	41	50383AF	77	50625	43
22799AH	57	50314F	41	50342BK	41	50383AR	77	50626D	59
22825	67	50317B	25	50342BP	41	50383E	45	50630	59
22841U	57	50317C	35	50342BS	37	50383F	45	50630A	59
22845A	59	50321F	27	50344AM	41	50383G	57	50630C	59
22875N	31	50321G	37	50344BC	23	50384	39	50630B32	59
22881C	41	50322AF	27	50344BE	23	50384A	39	50630B36	59
22894C	45	50322AG	37	50344BF	23	50387	49	50632A	33
22894J	63	50322AL	37	50344BU	23	50392AB	23	50633	65
22894P	51, 53	50322AR	51, 53	50344E	23	50392AV	31	50633A	65
22894T	27	50322BC	27	50345W	25	50392BA	29	50634	47
23420S8-1/8	61	50323B	45	50347R	45	50392BC	31	50634C	47
23420S9-1/8	61	50323L	45	50351A	25	50392V	29	50634D	47
23420U16-3/32	61	50323P	25	50352	25	50392Z	31	50634E	47



NUMERICAL INDEX OF PARTS

<u>Part No.</u>	<u>Page No.</u>	<u>Part No.</u>	<u>Page No.</u>	<u>Part No.</u>	<u>Page No.</u>	<u>Part No.</u>	<u>Page No.</u>	<u>Part No.</u>	<u>Page No.</u>
50634G	51, 53	51280K	55	661-70A	63	C50042Z16	67	SS6121610SP	65
50635	65	51908B8	41	661-96	51, 53	C50044E	29	SS6122030SP	65, 77
50637	47	51908B9	41	666-328	25	C50056B	33	SS6151812TP	39
50637A	47	51909C	41	667C16	69, 71	C50077D	65	SS6151920SP	33
50638	65	51909D8	41	667J33	41	C50077P	45	SS6153040SP	33
50640-29	47	51909D9	41	671-102A	35	C50078J	63	SS7060310SP	29, 45
50640A29	49	51959B	45	671-196	69, 71	C50078K	63	SS7080510TP	29
50642	41	53634C	41	671-66	69, 71	C50078M	63	SS7080520SP	25, 45
50642A	27	538A	41	671-85	69, 71	C50078N	63	SS7090520SP	31
50642B	67	56392G	31	671A360	77	C50078P	63	SS7090530SP	47, 49
50642D	65	56392H	31	671D42	71	C50082AP	63	SS7090610SP	29
50643C	33	56392M	31	671F19	63	C50082AR	63	SS7090610SP	35, 49
50647	65	57864B	61	671F64	63	CE27	25	SS7090850SP	57
50654	23	57865	31	671F81A	71	CE49	33	SS7091110TP	47, 59
50654A	23	57892K	31	671F81C	77	CE59	25	SS7092110TP	45
50657A	45	59451F	63	671F82C	69, 71	CE63	25, 41, 55	SS7111120TP	25, 27
50658A	29	604	65	671F82F	69, 71	LA452	35	SS7120640SP	29, 35
50658B	29, 35	605A	29	671F82H	69, 71	NS6110310SP	39	SS7120710SP	29
50662A	35	652C16	35	671F86B	69, 71	NS6110420SP	31	SS7120710SP	39, 57
50662B	65	660-1014	33	671F86D	71	NS6120310SP	77	SS7120910SP	41, 65
50663A	29	660-1020	57	671F88	71	NS6150310SP	33, 65	SS7120910TP	59
50666	29	660-1043	27	77B	45	NS6620320SP	35	SS7121410TP	31
50666A	29	660-1046	59	88B	67	PS0400142KH	23	SS7150740SP	55
50666C	29	660-1062	37	90561E	69, 71	RC0560711KP	43	SS7660520SP	27, 37
50667	57	660-1087	27	90561K	69, 71	RE0500000KO	33	SS7681410TP	27
50667A	65	660-1099	77	96902	69, 71	RM2871B	39	SS8080310TP	59
50668	43	660-168	69, 71	98	63	RM3211-12	65	SS8080410TP	29
50674	51	660-206	51, 53	99327	69, 71	RM3293-5	69, 71	SS8090540SP	65
50677	63	660-212	35	99372B	69, 71	RM4377-4	69, 71	SS8090710SP	49
50677A	63	660-220	49	99590Q	69, 71	RO068190100	33	SS8110422TP	25, 33
50677B	65	660-220	51, 53	99682XC	35	SD0380551SL	29, 45	SS8110422TP	43, 49
50677C	65	660-240	79	99682XC1	35	SD0630275SP	45	SS8110422TP	51, 53
50677E	65	660-264	79	99682XC2	35	SD0640323TP	35	SS8150822TP	65
50677F	65	660-283A	31	99682XCA	35	SD0790303SP	33	SS8660410SP	37
50677G	65	660-397	69, 71	998-358F	39	SPO550271TP	49	SS8660612TP	27, 37
50677H	65	660-403	69, 71	999-160	69, 71	SQ1110401MZ	23	SS8660612TP	39, 41
50677K	65	660-455	41	AS7-1	69, 71	SQ1110402MZ	39	SS8660612TP	47, 49
50677L	65	660-739	33	AS7-2	69, 71	SS1110640SL	35	SS8661012TP	27, 37
50677M	65	660-886	35	AS7-3	69, 71	SS1121010SP	29	SS8661012TP	51, 53
50677N	65	660-886A	63	B1647704000A	49	SS4080620TP	25	SS8681412TP	27
50677R	65	660-886B	63	B3103800400	31	SS4090815SP	29, 39	SS9080410SP	45
50677S	65	660-886C	63	B3112704000	31	SS4091015SP	39	SS9110430TP	65
50677T	65	660-887	65	B3120352000	31	SS4120615SP	35, 55	SS9110543CP	57
50677U	63	660-888	63	B3120704000	31	SS4120915SP	29	SS9111010SP	45
50682B	57	660-889	63	B3126012000	31	SS4120915SP	31, 35	SS9121210TP	65
50682D	57	660-890	63	B3530555000	35	SS4121015SP	57, 77	SS9151440CP	65
50683	29	660-891B	63	B4107850M00	65	SS4121215SP	33, 35	SS9151740CP	33
50684A	57	660-891C	63	C067D	55	SS4121215SP	49, 77	TA075404RO	51
50684B	35	660-892C	63	C50022L	63	SS4121615SP	35	TA1050504RO	35
50684C	35	660-893	41, 63	C50025E	43	SS4151415SP	57	TA1100604RO	35
50691	27	660-914	63	C50041D	41	SS6060440TP	45	W03	57
50692	31	660-918	63	C50041E	41	SS6080810SP	65	WPO480856SP	35
50692A	31	660-934	37	C50041F	41	SS6090440SP	25	WPO531000SD	65
50692D	31	660-939	55	C50041G	41	SS6090620SP	25, 43	WS0510002KP	77
50692E	29	660-969	51, 53	C50041H	41	SS6091022TP	49	WS0631510KP	39
50692J	31	660-979	41	C50042AC16	63	SS6110610TP	33, 45	WZ0640200KP	45
50695A	65	660-980	51, 53	C50042AD	65	SS6110650TP	49	WZ0641510KP	35
50696C	67	661-259B	25	C50042AF	63	SS6120930TP	57	WZ0850302KO	65
50696D	67	661-261	27	C50042Z13	67	SS6121010SP	25		
51170D	35	661-262	27	C50042Z14	67	SS6121050SP	35		
51242L	65	661-35	51, 53	C50042Z15	67	SS6121212TP	55		



NOTES



Union Special®
Industrial Sewing Equipment