



Union Special
INDUSTRIAL SEWING EQUIPMENT

STYLES

ILLUSTRATED PARTS LIST

51400

51700

51800

**STREAMLINED
FIFTY THOUSAND SERIES
CLOSE COUPLED PULLER**

**CATALOG
NO. 104R**

**FIRST
EDITION**



Catalog No. 104 R

LIST OF PARTS

Classes

51400 51700 51800

Styles

51400 BE 51800 BA
51700 BU 51800 BB

First Edition

Copyright 1961

By

Union Special Corporation
Rights Reserved in All Countries

UNION SPECIAL CORPORATION

INDUSTRIAL SEWING MACHINES

CHICAGO

Printed in U.S.A.

January, 1979

FOREWORD

The 50000 series streamlined close-coupled puller machines covered by this catalog represent the latest design of the UNION SPECIAL flatbed line. Light weight needle bars and driving mechanisms and light weight presser bars make it possible to attain the utmost in speed and production. The new light weight parts and needle bearings make them lighter running and smoother operating. The light weight presser bar mechanism reduces pressure required to lift the foot. The clutch mechanism for the close-coupled puller is housed in the upper roller, to insure a uniformly controlled feeding. All parts are made by precision methods insuring complete interchangeability.

Automatic lubrication and a new filter type oil return pump, used in conjunction with isolated mounting oil pan base plate, for returning filtered oil to the main reservoir has made maintenance simple.

It is our constant aim to furnish carefully prepared information which will enable our customers to secure all possible advantages from the use of UNION SPECIAL machines. The following pages illustrate and describe the parts used in all of the machines covered in this catalog.

Union Special representatives will be found in all manufacturing centers, ready to cooperate with you to plan and estimate requirements.

UNION SPECIAL CORPORATION

Engineering Department

IDENTIFICATION OF MACHINES

Each UNION SPECIAL machine carries a Style number which is stamped in the name plate on the machine. Style numbers are classified as standard and special. Standard Style numbers have one or more letters suffixed, but never contain the letter "Z". Example: "Style 51800 BA". Special Style numbers contain the letter "Z". When only minor changes are made in a standard machine, a "Z" is suffixed to the standard Style number. Example: "Style 51800 BAZ".

The distance between the rows of stitches or between needles is represented by a gauge number measured in 1/64ths of an inch, going from left to right. Thus, 16-64-16 gauge represents a distance of 16/64 or 1/4 inch between 1st (extreme left) and 2nd needles, a distance of 64/64 or 1 inch between 2nd and 3rd needles, and finally, a distance of 16/64 or 1/4 inch between 3rd and 4th needles. This would also indicate a four needle machine.

APPLICATION OF CATALOG

This catalog applies specifically to the standard Style of machines as listed herein. It can also be applied with discretion to some Special machines in Classes 51400, 51700, 51800. References to direction such as right, left, front, back, etc., are taken from the operator's position while seated at the machine. Operating direction of handwheel is toward the operator.

STYLE OF MACHINE IN CLASS 51400

Streamlined Flat Bed, Two Needle, Left Needle in Front, Independent Row, Low Throw, Close-Coupled Puller With Clutch in Upper Feed Roller, Double Disc Take-up, Light Weight Presser Bar and Needle Bar Driving Mechanism, Single Reservoir Enclosed Automatic Lubricating System, Filter Type Oil Return Pump and Oil Siphon Assembly, Lateral Loper Travel, Maximum Work Space to Right of Needle Bar 7 3/4 Inches.

51400 BE For hemming and simultaneously inserting elastic in tops and legs of knitted undergarments and for similar operations on light to medium weight materials. Seam specification 401-EFg-2. Type 106 GS needle. Standard gauges Nos. 16, 18, 24.

STYLE OF MACHINE IN CLASS 51700

Streamlined Flat Bed, Two Needle, Needles Abreast, Independent Row, High Throw, Close-Coupled Puller With Clutch in Upper Feed Roller and Tiltable Lower Feed Roller, Single Disc Take-up, Light Weight Presser Bar and Needle Bar Driving Mechanism, Single Reservoir Enclosed Automatic Lubricating System, Filter Type Oil Return Pump and Oil Siphon Assembly, Lateral Loper Travel, Maximum Work Space to Right of Needle Bar 7 3/4 Inches.

51700 BU For attaching waistband strips to dungarees, service pants, work trousers and for similar operations on medium heavy to heavy weight material. Strips guided next to feed dog. Seam specification 401-LSk-2. Type 128 GAS needle. Standard gauge No. 96 only.

STYLES OF MACHINES IN CLASS 51800

Streamlined Flat Bed, Four Needles, Left Needle in Front for Each Pair of Needles, Independent Row, High Throw, Close-Coupled Puller With Clutch in Upper Feed Roller, Single Disc Take-up, Light Weight Presser Bar and Needle Bar Driving Mechanism, Single Reservoir Enclosed Automatic Lubricating System, Filter Type Oil Return Pump and Oil Siphon Assembly, Lateral Loper Travel, Maximum Work Space to Right of Needle Bar 7 3/4 Inches.

STYLES OF MACHINES IN CLASS 51800 (Continued)

51800 BA For attaching bibs to overalls and for similar operations on medium heavy to heavy weight sanforized and non-sanforized materials. Strips used in long lengths guided next to feed dog. Floor treadle controlled strip collapsing mechanism. Knee press for raising presser foot. Seam specification 401-LS1-4. Type 130 GS needle. Standard gauges Nos. 12-56-12, 12-64-12, 16-64-16, 16-76-16.

51800 BB Same as 51800 BA, except it is not equipped with strip collapsing mechanism and has a floor treadle for raising the presser foot.

NEEDLES

Each UNION SPECIAL needle has both a type number and size number. The type number denotes the kind of shank, point, length, groove, finish and other details. The size number, stamped on the needle shank, denotes the largest diameter of blade, measured in thousandths of an inch, midway between the shank and the eye. Collectively, the type number and the size number is the complete symbol.

To have orders promptly and accurately filled, forward the empty package, a sample needle, or the type and size number should be given. See description on packages. A complete order would read as follows: "1000 Needles, Type 106 GHS-080/032".

The type numbers of the needles recommended for each style of machine covered by this catalog are given in the machine style description. Other needles are available, but the ones indicated are those recommended to produce the most satisfactory results. The type numbers of the recommended needles, together with their descriptions, and the sizes available are listed below:

<u>Type No.</u>	<u>Description and Sizes</u>
106 GHS	Round shank, round point, extra short, double groove, struck groove, ball eye, ball point, chromium plated - sizes 070/027, 075/029, 080/032, 090/036.
128 GAS	Round shank, round point, short, double groove, struck groove, ball eye, spotted, chromium plated - sizes 080/032, 090/036, 100/040, 110/044, 125/049, 140/054, 150/060, 170/067.
130 GS	Round shank, round point, short, double groove, struck groove, ball eye, spotted, government, chromium plated - sizes 080/032, 090/036, 100/040, 110/044, 125/049, 140/054, 150/060.

Selection of the proper needle size should be determined by the size of thread used. Thread should pass freely through needle eye in order to produce a good stitch formation.

ORDERING REPAIR PARTS

ILLUSTRATIONS

This catalog has been arranged to simplify ordering repair parts. Exploded views of various sections of the mechanism are shown so that the parts may be seen in their actual position in the machine. On the page opposite the illustration will be found a listing of the parts with their parts numbers, descriptions and the number of pieces required in the particular view being shown.

ORDERING REPAIR PARTS (Continued)

Numbers in the first column are reference numbers only, and merely indicate the position of that part in the illustration. Reference numbers should never be used in ordering parts. Always use the part number listed in the second column.

Component parts of sub-assemblies which can be furnished for repairs are indicated by indenting their descriptions under the description of the main sub-assembly. Example:

49	29105 AA	Looper Drive Lever Eccentric Assembly -----	1
50	22559 A	Bearing Cap Screw, lower-----	2
51	22559 B	Bearing Cap Screw, upper-----	2
52	22894 C	Eccentric Set Screw -----	4
53	22894 D	Eccentric Spot Screw -----	1

It will be noted in the above example that the eccentric, ball stud and bearing are not listed. The reason is that replacement of these parts individually is not recommended, so the complete sub-assembly should be ordered.

In those cases where a part is common to all of the machines covered by this catalog, no specific usage will be mentioned in the description. However, when the parts for the various machines are not the same, the specific usage will be mentioned in the description and, if necessary, the difference will be shown in the illustration.

At the back of the book will be found a numerical index of all the parts shown in this book. This will facilitate locating the illustration and description when only the part number is known.

IDENTIFYING PARTS

Where the construction permits, each part is stamped with its part number. On some of the smaller parts, and on those where construction does not permit, an identification letter is stamped in to distinguish the part from similar ones.

Part numbers represent the same part, regardless of catalog in which they appear.

IMPORTANT! ON ALL ORDERS, PLEASE INCLUDE PART NAME AND STYLE OF MACHINE FOR WHICH PART IS ORDERED.

USE GENUINE NEEDLES AND REPAIR PARTS

Success in the operation of these machines can be secured only with genuine UNION SPECIAL Needles and Repair Parts as furnished by the Union Special Corporation, its subsidiaries and authorized distributors. They are designed according to the most approved scientific principles, and are made with utmost precision. Maximum efficiency and durability are assured.

Genuine needles are packaged with labels marked *Union Special*. Genuine repair parts are stamped with the Union Special trademark, U S Emblem. Each trademark is your guarantee of the highest quality in materials and workmanship.

TERMS

Prices are net cash and subject to change without notice. All shipments are forwarded f. o. b. shipping point. Parcel Post shipments are insured unless otherwise directed. A charge is made to cover postage and insurance.

OILING AND THREADING

The oil has been drained from the machine before shipping and the reservoir must be filled before beginning to operate. Use a straight mineral oil with a Saybolt viscosity of 90 to 125 seconds at 100° Fahrenheit.

Oil is filled at the spring cap in the top cover and the level is checked at the sight gauge on the front of the machine. The oil level should be maintained between the red lines on the gauge. The capacity of the reservoir is 12 ounces.

The machine is automatically lubricated and no oiling other than keeping the main reservoir filled is necessary.

A daily check before the morning start should be made and oil added if required. Oil which has gone through the machine is filtered and pumped back into the main reservoir making too frequent oilings unnecessary. Excessive oil in the main reservoir may be drained at the plug screw in the main frame directly under the handwheel.

The accompanying drawing also shows the manner in which a four needle machine is threaded. Two needle machines are threaded in substantially the same manner. The looper threading of the various classes is indicated in the inserts.

FILL
MAIN
RESERVOIR
HERE

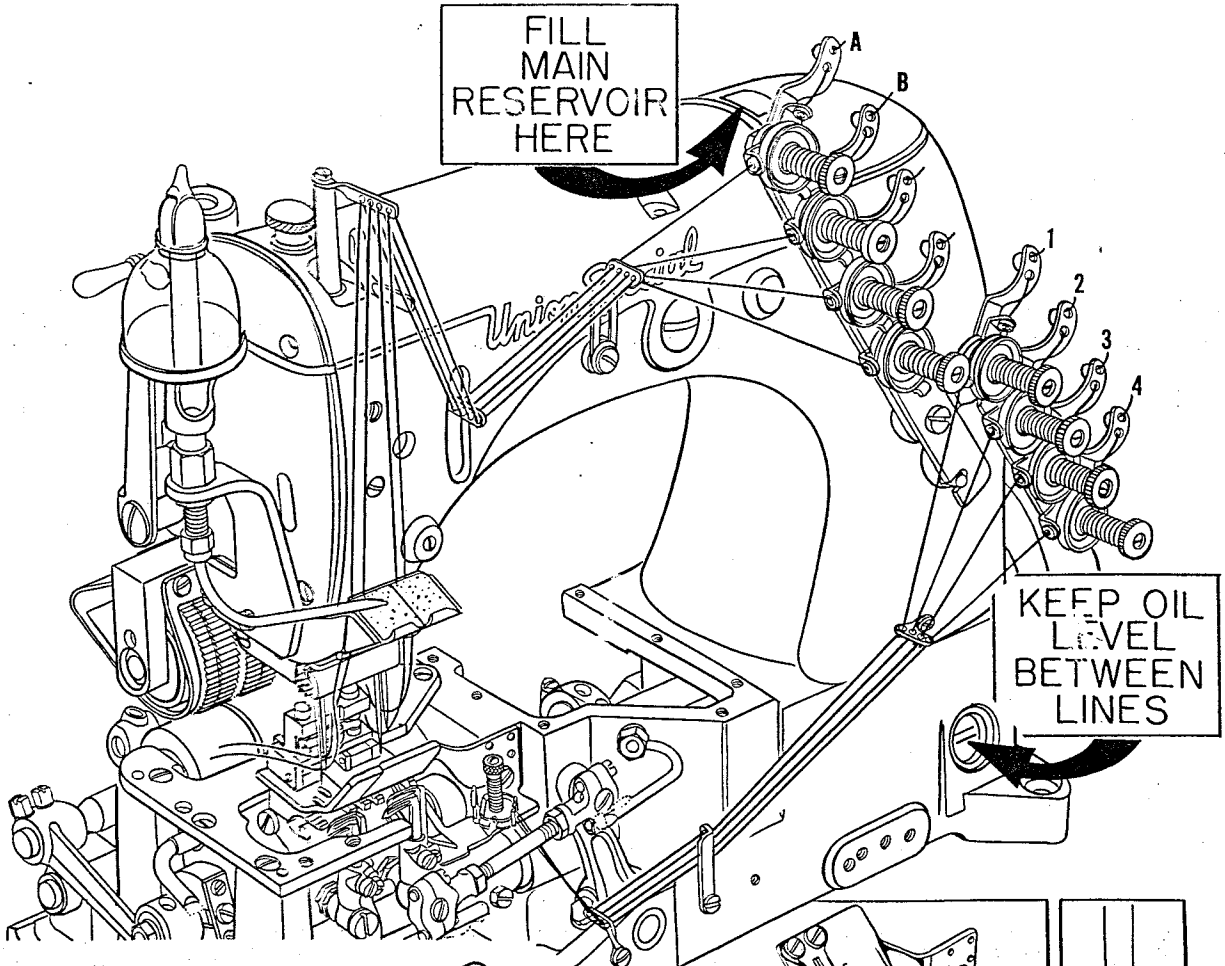

KEEP OIL
LEVEL
BETWEEN
LINES

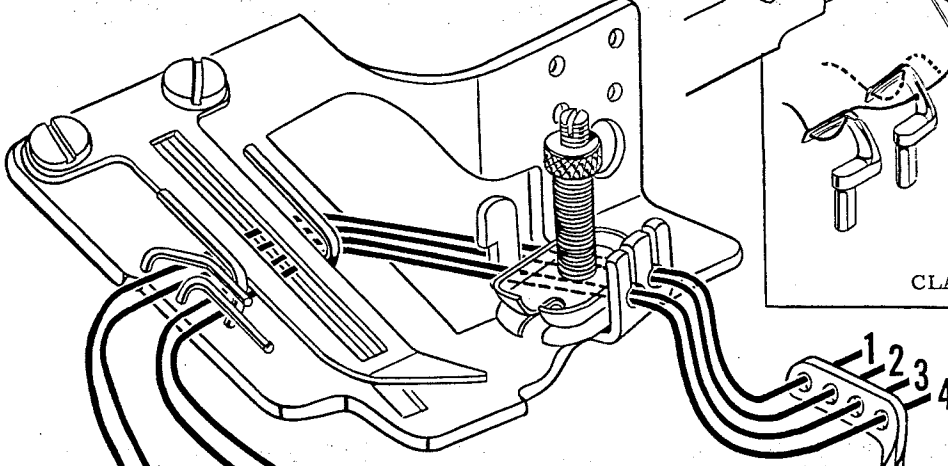

CLASS 51800

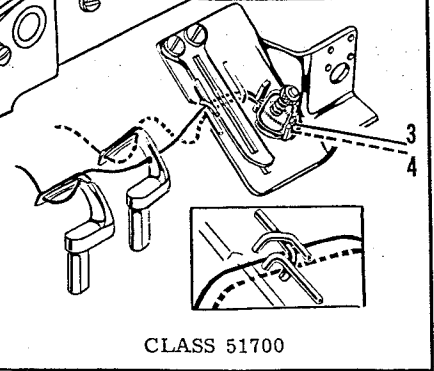

CLASS 51700

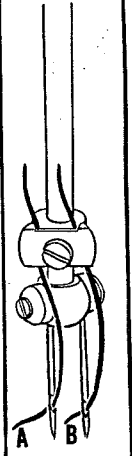

A B

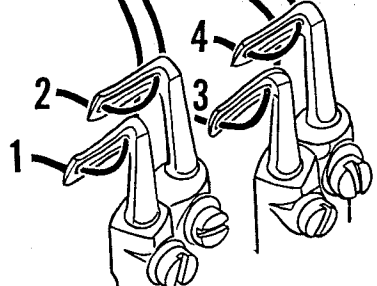

CAUTION!
FILL ALL OIL RESERVOIRS
BEFORE STARTING.
MACHINE HAS BEEN DRAINED
BEFORE SHIPPING.

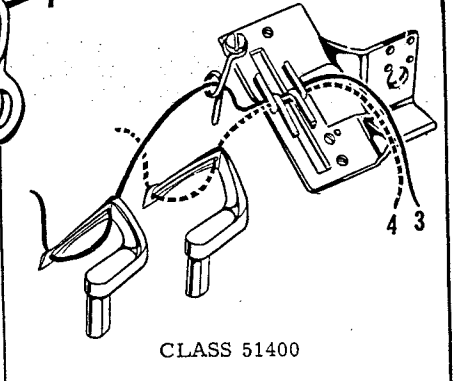

CLASS 51400

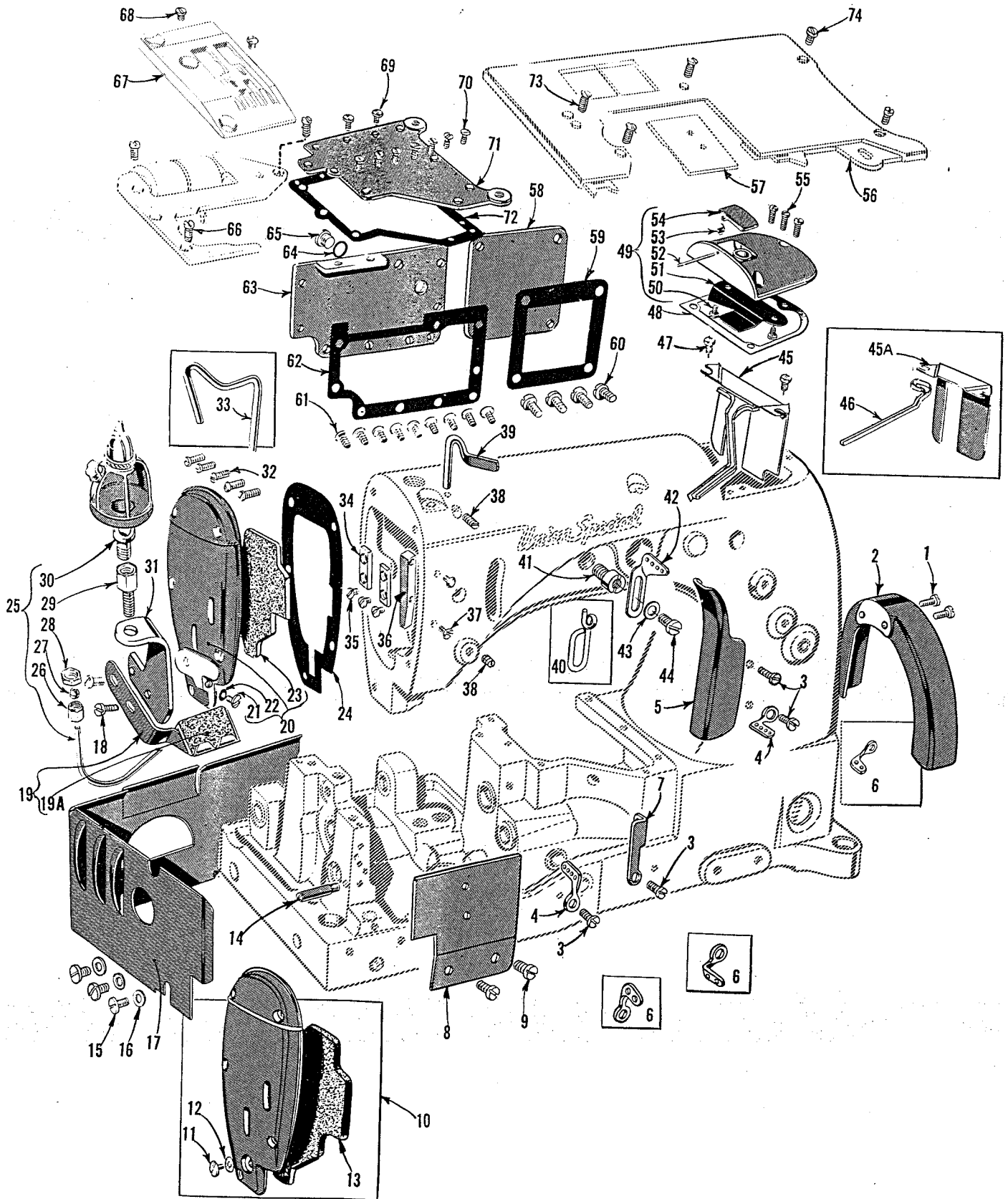

MAIN FRAME, MISCELLANEOUS COVERS AND PLATES

Ref. No.	Part No.	Description	Amt. Req.
1	93	Screw -----	2
2	BB21375 AH	Belt Guard -----	1
3	98 A	Screw -----	4
4	1068	Thread Eyelet, for Style 51800 BA -----	2
	1068	Thread Eyelet, for Style 51800 BB -----	3
5	51291 A	Looper Thread Guard -----	1
6	158 B	Thread Eyelet, for Styles 51400 BE, 51700 BU -----	3
7	51859 B	Thread Eyelet, for Style 51800 BA -----	1
8	51482 A	Cloth Guard, for Style 51400 BE -----	1
9	25 S	Screw, for Style 51400 BE -----	2
10	51282 Y	Head Cover, for Styles 51400 BE, 51700 BU -----	1
11	22542	Screw -----	1
12	52882 W	Washer -----	1
13	51282 AC	Felt Liner -----	1
14	22799 M	Screw, for strip collapsing device mounting bracket on Style 51800 BA -----	1
15	22848	Screw -----	3
16	20	Washer -----	3
17	51282 AH	Oil Shield -----	1
18	22541	Screw, for Styles 51800 BA, BB -----	2
19	21396 BP	Needle Thread Lubricator, for Styles 51800 BA, BB -----	1
19A	21396 AG	Felt Pad -----	2
20	51782 A	Head Cover, for Styles 51800 BA, BB -----	1
21	22542	Screw -----	1
22	52882 W	Washer -----	1
23	51282 AC	Gasket -----	1
24	51282 Z	Gasket -----	1
25	21396 BJ	Thread Oiler, for Styles 51800 BA, BB -----	1
26	660-75	Coupling -----	1
27	660-74	Sleeve -----	1
28	11638 M	Nut -----	1
29	61394 V	Adapter -----	1
30	666-79	Oiler -----	1
31	21396 BK	Thread Oiler Bracket, for Styles 51800 BA, BB -----	1
32	22569 B	Screw -----	5
33	51270	Take-up Wire, for Styles 51400 BE, 51700 BU -----	1
34	35731 A	Presser Bar Connection Guide Plate -----	2
35	22513	Screw -----	3
36	51454 A	Needle Bar Guide Block, for Styles 51700 BU, 51800 BA, BB -----	1
37	22849	Screw, for Styles 51700 BU, 51800 BA, BB -----	2
38	95	Screw -----	2
39	51870	Take-up Wire, for Style 51800 BA, BB -----	1
40	51758	Frame Needle Thread Eyelet, for Styles 51400 BE, 51700 BU -----	1
41	22889 A	Adapter Screw -----	1
42	51858	Frame Needle Thread Eyelet, for Style 51800 BA, BB -----	1
43	20	Washer -----	1
44	22848	Screw -----	1
45	56382 AC	Needle Lever Bearing Oiler and Baffle Plate, for Style 51400 BE -----	1
45A	52882 Y	Baffle Plate, for Styles 51700 BU, 51800 BA, BB -----	1
46	51282 AE	Needle Lever Bearing Oiler, for Styles 51700 BU, 51800 BA, BB -----	1
47	90	Screw -----	2
48	52882 P	Crank Chamber Cover Gasket -----	1
49	52882 AD	Crank Chamber Cover, upper -----	1
50	90	Screw -----	2
51	52882 AA	Oil Drip Plate -----	1
52	50-789 Blk	Pin -----	1
53	52882 AC	Spring -----	1
54	39582 L	Oil Cap -----	1
55	22541 B	Screw -----	3
56		Cloth Plate (See Page 27) -----	1
57		Cloth Plate Cover (See Page 27) -----	1
58	52882 AE	Crank Chamber Cover, lower -----	1
59	52882 U	Gasket -----	1
60	22548	Screw -----	4
61	22848	Screw -----	9
62	52882 M	Gasket -----	1
63	52882 L	Oil Reservoir Back Cover -----	1
64	41394 A	Gasket -----	2
65	22733 B	Plug Screw -----	1
66	22839	Screw -----	1
67		Throat Plate (See Pages 29, 31) -----	1
68	87	Screw, for throat plate -----	2
69	22585 A	Screw -----	2
70	22524	Screw -----	7
71	53782 B	Oil Reservoir Top Cover -----	1
72	51382 A	Gasket -----	1
73	80	Screw, for cloth plate -----	3
74	22839 C	Screw, for cloth plate -----	2

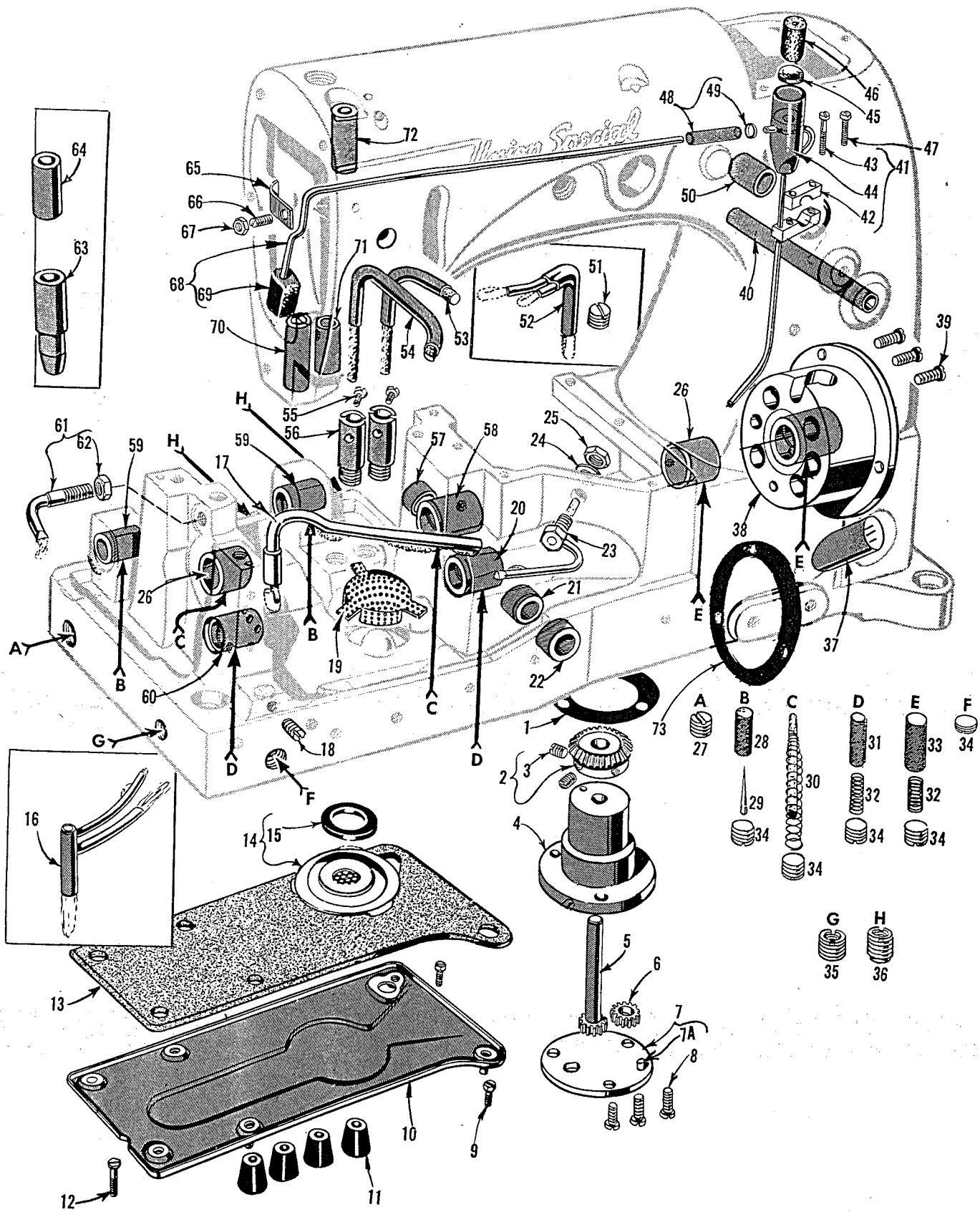

MAIN FRAME, BUSHINGS AND MISCELLANEOUS OILING PARTS

Ref. No.	Part No.	Description	Amt. Req.
1	643-127	Gasket	1
2	51493 BQ	Oil Pump Driven Gear	1
3	531	Screw	2
4	51493 AG	Oil Pump Housing	1
5	51493 D	Oil Pump Driving Shaft	1
6	51493 E	Oil Pump Driving Shaft Gear	2
7	51493 AH	Oil Pump Housing Cover	1
7A	50-294 Blk	Pin	1
8	22569 B	Screw	3
9	22823 A	Screw	2
10	51493 AY	Base Plate, for Style 51800 BB	1
	51493 BA	Base Plate, for Styles 51400 BE, 51700 BU	1
	51493 BD	Base Plate, for Style 51800 BA	1
11	51295 A	Mounting Isolator	4
12	22823 B	Screw	1
13	51493 BG	Base Plate Felt	1
14	51493 BH	Filter Cap Assembly	1
15	51493 BJ	Washer, rubber	1
16	52894 AK	Oil Tube, for looper rocker ball joint, left, on Style 51400 BE	1
17	51794 C	Oil Tube, for looper rocker ball joint, left, on Styles 51700 BU, 51800 BA, BB	1
18	22560 B	Screw	1
19	51493 BK	Lint Filter Screen	1
20	52944 U	Looper Rock Shaft Bushing, right	1
21	51242 R	Looper Drive Lever Shaft Bushing, middle	1
22	51242 Z	Looper Drive Lever Shaft Bushing, front	1
23	52894 AM	Oil Tube, for looper connecting rod ball joint, right	1
24	6042 A	Washer	1
25	258 A	Nut	1
26	52890 C	Main Shaft Bushing, left, inner right	2
27	22539 H	Plug Screw	1
28	666-111	Oil Wick	2
29	666-179	Wedge Pin	2
30	666-118	Oil Wick	2
31	666-65	Oil Wick	2
32	35178 D	Spring	4
33	666-114	Oil Wick	2
34	22571 A	Plug Screw	15
35	22889 D	Adaptor Plug Screw	1
36	22889 C	Adaptor Plug Screw	2
37	50-648 Blk	Lucite Oil Gauge	1
38	52891 B	Crankshaft Bushing Housing, including bushing	1
39	22569 B	Screw	3
40	21657 X	Tension Release Lever Shaft Bushing	1
41	51294 U	Oil Siphon Assembly	1
42	51294 K	Clamp, upper	1
43	22729 B	Screw	1
44	643-263	Siphon	1
45	666-209	Felt Plug	1
46	666-201	Felt Disc	1
47	22729 A	Screw	1
48	51294 Z	Oil Tube Connection	1
49	21212	Locking Ring, for oil siphon connection	1
50	52883 R	Foot Lifter Lever Bushing	1
51	22571 B	Plug Screw, for Style 51400 BE	1
52	52994 AC	Oil Tube, for feed lift and looper avoid eccentric, on Style 51400 BE	1
53	51794 B	Oil Tube, for looper avoid eccentric, on Styles 51700 BU, 51800 BA, BB	1
54	54293 A	Oil Tube, for feed lift eccentric, on Styles 51700 BU, 51800 BA, BB	1
55	90	Screw, for Styles 51700 BU, 51800 BA, BB	2
	90	Screw, for Style 51400 BE	1
56	52894 AB	Oil Tube Holder, for Styles 51700 BU, 51800 BA, BB	2
	52894 AB	Oil Tube Holder, for Style 51400 BE	1
57	51242 S	Looper Drive Lever Shaft Bushing, rear	1
58	51290 T	Main Shaft Bushing, middle	1
59	52936	Feed Rocker Shaft Bushing	2
60	52944 T	Looper Rock Shaft Bushing, left	1
61	660-136	Oil Tube, for feed crank link	1
62	258 A	Nut	1
63	51254 C	Needle Bar Bushing, upper, for Style 51400 BE	1
64	51254 D	Needle Bar Bushing, lower, for Style 51400 BE	1
65	51294 P	Oil Tube Clamp	1
66	51294 R	Screw	1
67	7947	Nut	1
68	51294 M	Oil Siphon Tube	1
69	666-214	Felt Lint Filter	1
70	51257 AA	Presser Bar Bushing, lower	1
71	51854 E	Needle Bar Bushing, lower, for Styles 51700 BU, 51800 BA, BB	1
72	51854 F	Needle Bar Bushing, upper, for Styles 51700 BU, 51800 BA, BB	1
73	56390 E	Bearing Housing Gasket	1

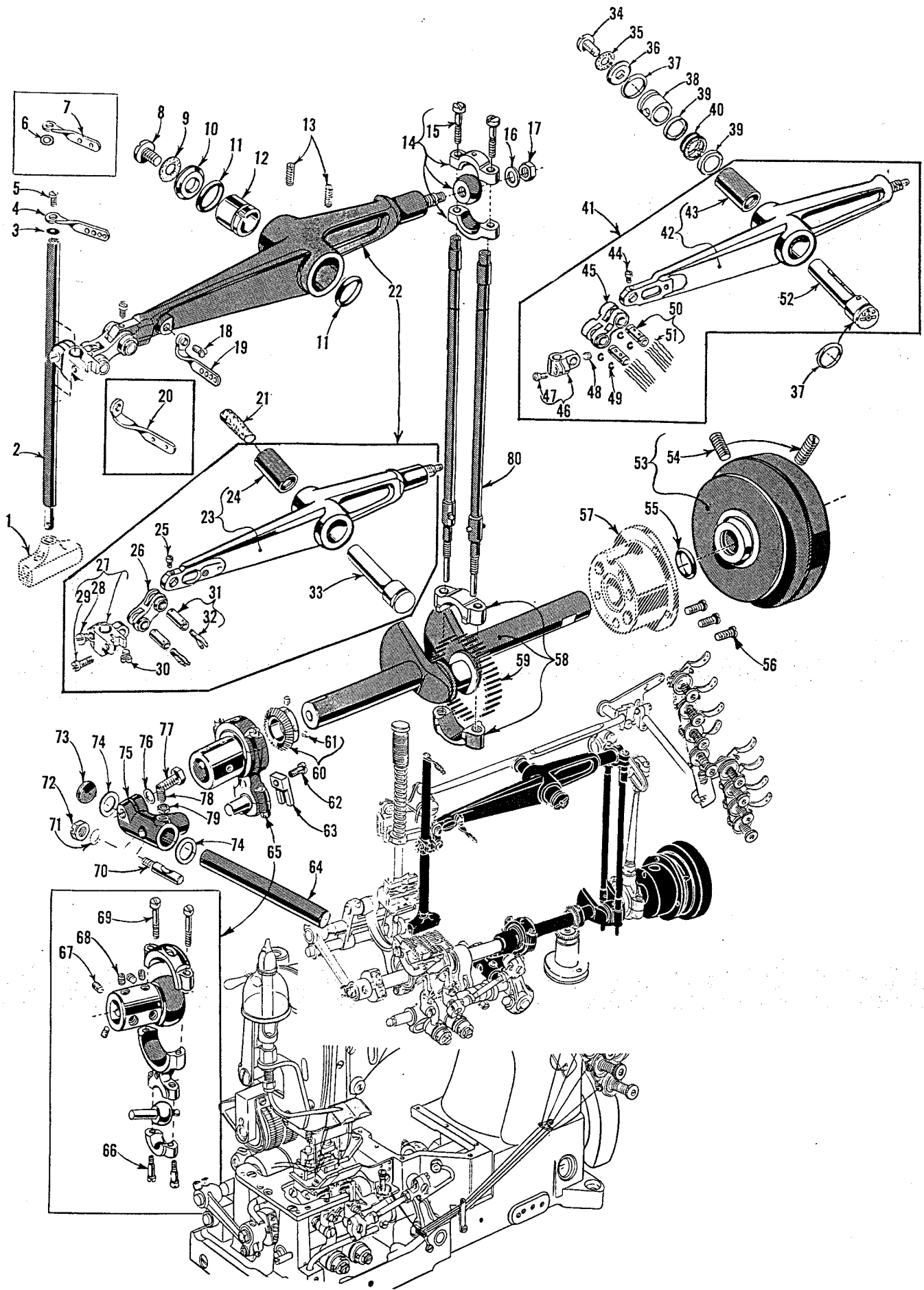

CRANKSHAFT, NEEDLE LEVER AND LOOPER DRIVING PARTS

Ref. No.	Part No.	Description	Amt. Req.
1		Needle Holder (See Page 27) -----	1
2		Needle Bar (See Page 27) -----	1
3	27-484 Blk	Eyelet Lock Washer, for Styles 51700 BU, 51800 BA, BB -----	1
4	54158 A	Needle Bar Thread Eyelet, for Styles 51800 BA, BB -----	1
5	22768	Screw -----	1
6	27-435 Blk	Eyelet Lock Washer, for Style 51400 BE -----	1
7	56458 A	Needle Bar Thread Eyelet, for Styles 51400 BE, 51700 BU -----	1
8	22586 R	Screw -----	1
9	51250 F	Gasket -----	1
10	51250 D	Washer -----	1
11	660-212	Oil Seal Ring -----	2
12	51150	Needle Lever Thrust Collar, for Styles 51700 BU, 51800 BA, BB -----	1
13	719	Screw -----	2
14	29066 R	Needle Lever Connecting Rod Ball Assembly -----	1
15	22559 G	Screw -----	2
16	51216 N	Washer -----	1
17	51216 P	Nut -----	1
18	22768	Screw -----	1
19	54158	Needle Lever Thread Eyelet, for Styles 51800 BA, BB -----	1
20	56458	Needle Lever Thread Eyelet, for Styles 51400 BE, 51700 BU -----	1
*21	666-170	Oil Wick, for needle lever stud -----	1
22	29348 S	Needle Lever Assembly, for Styles 51700 BU, 51800 BA, BB -----	1
23	56315	Needle Lever -----	1
24	56350 B	Needle Lever Bushing -----	1
25	77	Screw -----	1
26	56354 A	Needle Bar Connecting Link -----	1
27	51454 B	Needle Bar Connection -----	1
28	22516 B	Screw -----	1
29	75 C	Screw -----	1
30	77	Screw -----	1
31	51054	Link Pin -----	2
32	666-149	Lubricating Felt -----	1
33	56350 A	Needle Lever Stud -----	1
34	22586 R	Screw -----	1
35	51250 F	Gasket -----	1
36	51250 D	Washer -----	1
37	660-212	Oil Seal Ring -----	2
38	56350 E	Needle Lever Thrust Collar, for Style 51400 BE -----	1
39	56350 F	Thrust Washer, for Style 51400 BE -----	2
40	660-614	Temper Load Ring, for Style 51400 BE -----	1
41	29348 AF	Needle Lever Assembly, for Style 51400 BE -----	1
42	56315 A	Needle Lever -----	1
43	56350 G	Needle Lever Bushing -----	1
44	77	Screw -----	1
45	56354 D	Needle Bar Connection Link -----	1
46	51254 K	Needle Bar Connection -----	1
47	22562 A	Screw -----	1
48	22564	Screw -----	1
49	660-215	Retaining Ring -----	4
50	52336 A	Connecting Pin -----	2
51	WO-3	Columbia Yarn (6 stands) -----	-
52	56350 D	Needle Lever Stud -----	1
53	52921 B	Handwheel, for No. "V" or round belt -----	1
54	22894 G	Screw -----	2
55	660-202	Oil Seal Ring -----	1
56	22569 B	Screw -----	3
57	52891 B	Crankshaft Bushing Housing, including bushing -----	1
58	29476 HE	Crankshaft Assembly, .770 inch throw, for Style 51400 BE -----	1
-	29476 HD	Crankshaft Assembly, .990 inch throw, for Styles 51700 BU, 51800 BA, BB -----	1
59	51216 M	Needle Bearing -----	28
60	51493 BP	Oil Pump Driving Gear -----	1
61	22560 B	Screw -----	2
62	22729	Screw -----	1
63	51243 C	Ball Stud Guide Fork -----	1
64	51242 P	Looper Drive Lever Shaft -----	1
65	29105 AA	Looper Drive Lever Eccentric Assembly -----	1
66	22559 A	Bearing Cap Screw, lower -----	2
67	22894 D	Eccentric Spot Screw -----	1
68	22894 C	Eccentric Set Screw -----	4
69	22559 B	Bearing Cap Screw, upper -----	2
70	52841 G	Locking Stud -----	1
71	51242 M	Washer -----	1
72	52841 J	Nut -----	1
73	22883 A	Plug Screw -----	1
74	51242 L	Thrust Washer -----	2
75	51242 Y	Looper Drive Lever Rocker -----	1
76	51242 M	Washer -----	1
77	22852 A	Clamp Screw -----	1
78	81	Spot Screw -----	1
79	12982	Lock Nut -----	1
80	51216 G	Needle Lever Connecting Rod -----	2

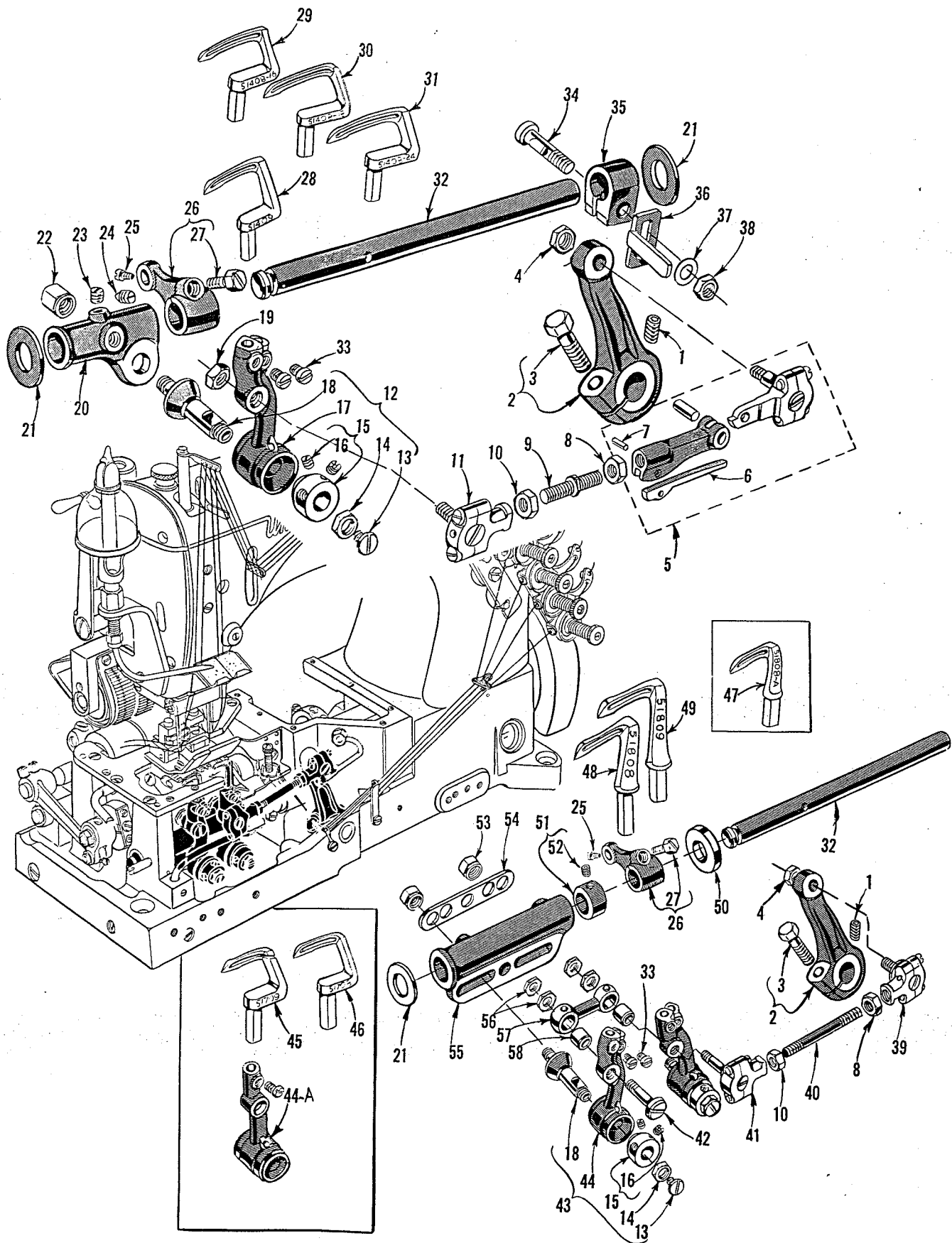

LOOPER ROCKER AND CONNECTING ROD PARTS

<u>Ref. No.</u>	<u>Part No.</u>	<u>Description</u>	<u>Amt. Req.</u>
1	22894 H	Spot Screw -----	1
2	51242 W	Looper Drive Lever -----	1
3	22811 B	Screw -----	1
4	12538	Nut -----	1
5	51241 K	Looper Connecting Rod Ball Joint, right, for Style 51400 BE -----	1
6	56341 G	Spring -----	1
7	50-458 Blk	Pin -----	1
8	18	Nut, right thread -----	1
9	51240 E	Looper Connecting Rod, for Style 51400 BE -----	1
10	269	Nut, left thread -----	1
11	55241 N	Looper Connecting Rod Ball Joint, left, for Style 51400 BE -----	1
12	29192 D	Looper Rocker Assembly, for Style 51400 BE -----	1
13	22829	Lock Nut Screw -----	1
14	258 A	Lock Nut -----	1
15	15465 F	Looper Rocker Cone -----	1
16	88	Set Screw -----	2
17	51513	Looper Rocker -----	1
18	51745	Looper Rocker Cone Stud -----	1
19	18	Nut, for Style 51400 BE -----	1
20	51244	Looper Rocker Frame, for Style 51400 BE -----	1
21	51244 L	Thrust Washer, for Style 51400 BE -----	2
	51244 L	Thrust Washer, for Styles 51700 BU, 51800 BA, BB -----	1
22	51246	Looper Rocker Stud Nut, for Style 51400 BE -----	1
23	98	Set Screw -----	1
24	96	Spot Screw -----	1
25	22768	Screw -----	1
26	51244 B	Looper Rocker Shaft Arm -----	1
27	22519 H	Screw -----	1
28	51409	Looper, back, for Style 51400 BE -----	1
29	51408-16	Looper, front, for No. 16 gauge on Style 51400 BE -----	1
30	51408-18	Looper, front, for No. 18 gauge on Style 51400 BE -----	1
31	51408-24	Looper, front, for No. 24 gauge on Style 51400 BE -----	1
32	51144	Looper Rocker Rock Shaft -----	1
33	73	Screw, for No. 29192 K -----	4
	73	Screw, for Nos. 29192 C, 29192 D -----	2
34	55244 G	Locking Stud, for Style 51400 BE -----	1
35	51244 N	Looper Rocker Shaft Clamp Collar, for Style 51400 BE -----	1
36	52470	Stop for Looper Connecting Rod, for Style 51400 BE -----	1
37	51216 N	Washer, for Style 51400 BE -----	1
38	18	Nut, for Style 51400 BE -----	1
39	51741 C	Looper Connecting Rod Ball Joint, right, for Styles 51700 BU, 51800 BA, BB ---	1
40	4761	Looper Connecting Rod, for Style 51700 BU -----	1
	41047	Looper Connecting Rod, for Styles 51800 BA, BB -----	1
41	55641	Looper Connecting Rod Ball Joint, left, for Styles 51700 BU, 51800 BA, BB ---	1
42	22835	Looper Rocker Link Stud, for Styles 51700 BU, 51800 BA, BB -----	1
43	29192 C	Looper Rocker Assembly, for Style 51700 BU -----	2
	29192 K	Looper Rocker Assembly, for Styles 51800 BA, BB -----	2
44	51813	Looper Rocker, for No. 29192 K -----	1
44A	51713	Looper Rocker, for No. 29192 C -----	1
45	51709	Looper, left, for Style 51700 BU -----	1
46	51708	Looper, right, for Style 51700 BU -----	1
47	51808 A	Looper, front, for Nos. 16-64-16 and 16-76-16 gauge on Styles 51800 BA, BB --	2
48	51808	Looper, front, for Nos. 12-56-12 and 12-64-12 gauge on Styles 51800 BA, BB --	2
49	51809	Looper, back, for all gauges on Styles 51800 BA, BB -----	2
50	54244 L	Thrust Washer, for Styles 51700 BU, 51800 BA, BB -----	1
51	51773	Spacing Collar, for Styles 51700 BU, 51800 BA, BB -----	1
52	88 B	Screw -----	1
53	1280	Looper Rocker Stud Nut, for Styles 51700 BU, 51800 BA, BB -----	2
	51772-56	Looper Rocker Spacing Plate, for No. 96 gauge on Style 51700 BU -----	1
54	51772-68	Looper Rocker Spacing Plate, for No. 12-56-12 gauge on Styles 51800 BA, BB --	1
	51772-76	Looper Rocker Spacing Plate, for No. 12-64-12 gauge on Styles 51800 BA, BB --	1
	51772-80	Looper Rocker Spacing Plate, for No. 16-64-16 gauge on Styles 51800 BA, BB --	1
	51772-92	Looper Rocker Spacing Plate, for No. 16-76-16 gauge on Styles 51800 BA, BB --	1
55	51744 A	Looper Rocker Frame, for Styles 51700 BU, 51800 BA, BB -----	1
56	14077	Nut, for Style 51700 BU -----	2
	14077	Nut, for Styles 51800 BA, BB -----	4
57	51770-68	Looper Rocker Link, for No. 12-56-12 gauge on Styles 51800 BA, BB -----	1
	51770-76	Looper Rocker Link, for No. 12-64-12 gauge on Styles 51800 BA, BB -----	1
	51770-80	Looper Rocker Link, for No. 16-64-16 gauge on Styles 51800 BA, BB -----	1
	51770-92	Looper Rocker Link, for No. 16-76-16 gauge on Styles 51800 BA, BB -----	1
	51770-96	Looper Rocker Link, for No. 96 gauge on Style 51700 BU -----	1
58	51771	Looper Rocker Link Bushing, for Styles 51700 BU, 51800 BA, BB -----	2

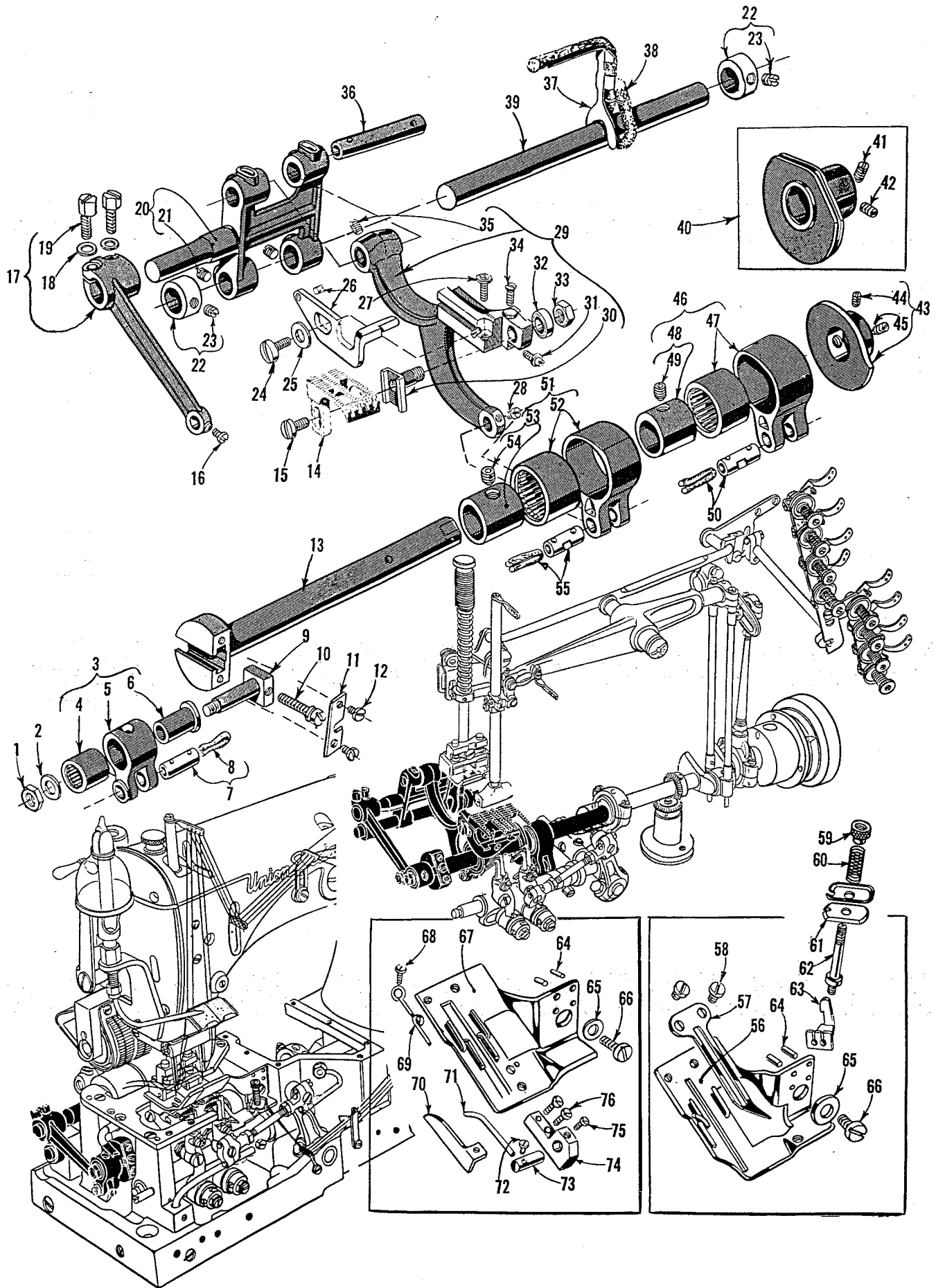

MAIN SHAFT, FEED DRIVING PARTS AND LOOPER THREAD TAKE-UP PARTS

<u>Ref. No.</u>	<u>Part No.</u>	<u>Description</u>	<u>Amt. Req.</u>
1	269	Nut, left thread -----	1
2	20	Washer-----	1
3	51236 E	Feed Crank Link, complete-----	1
4	660-169	Needle Bearing -----	1
5	51236 D	Feed Crank Link-----	1
6	51236 F	Feed Crank Link Ferrule -----	1
7	51054	Link Pin-----	1
8	666-149	Oil Wick -----	1
9	51236 G	Feed Crank Stud-----	1
10	82	Stitch Regulating Screw -----	1
11	51236 B	Feed Crank Stud Cap-----	1
12	22768	Screw-----	2
13	51222	Main Shaft, for Style 51400 BE-----	1
	51722	Main Shaft, for Styles 51700 BU, 51800 BA, BB -----	1
		Feed Dog (See Pages 29, 31)-----	1
14		Screw-----	1
15	22528	Screw-----	1
16	77	Screw-----	1
17	51235 A	Feed Rocker Arm -----	1
18	51235 G	Washer-----	2
19	22519 C	Screw -----	2
20	51235	Feed Rocker -----	1
21	98	Screw-----	2
22	482	Feed Rocker Shaft Collar-----	2
23	98	Screw-----	1
24	22585 B	Needle Guard Screw -----	1
25	51225 W	Washer-----	1
26		Needle Guard (See Page 27)-----	1
27	22834	Needle Guard Adjusting Screw -----	1
28	77	Screw-----	1
29	51434	Feed Bar -----	1
30	56334 L	Feed Dog Holder -----	1
31	22863	Feed Dog Holder Adjusting Screw -----	1
32	51134 J	Feed Dog Holder Washer-----	1
33	258	Nut -----	1
34	538	Feed Dog Height Adjusting Screw -----	1
35	22560 B	Screw-----	1
36	51134 C	Feed Bar Shaft-----	1
37	51134 R	Lubricating Felt Guard-----	1
38	51134 P	Lubricating Felt-----	1
39	8	Feed Rocker Shaft -----	1
40	51423 C	Looper Thread Take-up, for Style 51400 BE-----	1
41	96	Spot Screw -----	1
42	22580 D	Set Screw -----	1
43	51723 A	Looper Thread Take-up, for Styles 51700 BU, 51800 BA, BB -----	1
44	96	Spot Screw -----	1
45	22580 D	Set Screw -----	1
46	29476 DV	Looper Avoid Eccentric Assembly-----	1
47	51145 A	Eccentric Bearing-----	1
48	51406	Looper Avoid Eccentric, .062 inch throw -----	1
49	22894 D	Spot Screw -----	1
50	51236 A	Link Pin (includes felt wick) -----	1
51	29476 DV	Feed Lift Eccentric Assembly -----	1
52	51145 A	Eccentric Bearing-----	1
53	51406	Feed Lift Eccentric, .062 inch throw-----	1
54	22894 D	Spot Screw -----	1
55	51236 A	Link Pin (includes felt wick) -----	1
56	51757 B	Cast-off Plate Support, for Styles 51700 BU, 51800 BA, BB-----	1
57	51704	Cast-off Wire, for Style 51700 BU, 51800 BA, BB -----	1
58	28	Screw, for cast-off wire -----	2
59	51959 D	Tension Nut, for Styles 51700 BU, 51800 BA, BB -----	1
60	51959 K	Tension Spring, for Styles 51700 BU, 51800 BA, BB -----	1
61	51959 B	Tension Disc, for Styles 51700 BU, 51800 BA, BB -----	2
62	51492	Tension Post, for Styles 51700 BU, 51800 BA, BB -----	1
63	51459 A	Thread Guide, for Styles 51700 BU, 51800 BA, BB-----	1
64	50-216Blk	Dowel Pin -----	2
65	21657 E	Washer-----	1
66	22528	Screw-----	1
67	51257 P	Cast-off Support, for Style 51400 BE -----	1
68	22768	Screw, for Style 51400 BE-----	1
69	52958	Take-up Thread Eyelet, for Style 51400 BE -----	1
70	51204 B	Cast-off, for Style 51400 BE-----	1
71	51204	Looper Thread Retaining Finger, for Style 51400 BE -----	1
72	22798 A	Screw, for Style 51400 BE-----	1
73	51204 A	Looper Thread Retaining Finger Holder, for Style 51400 BE -----	1
74	51204 C	Cast-off and Retaining Finger Support Bracket, for Style 51400 BE -----	1
75	77	Screw, for Style 51400 BE-----	1
76	J87 J	Screw, for Style 51400 BE-----	2

THREAD TENSION AND LIFTER LEVER PARTS

<u>Ref. No.</u>	<u>Part No.</u>	<u>Description</u>	<u>Amt. Req.</u>
1	43266	Nut, for Styles 51400 BE, 51700 BU -----	2
	43266	Nut, for Styles 51800 BA, BB -----	7
2	51491 C	Lead-in Guide, for Styles 51400 BE, 51700 BU -----	4
	51491 C	Lead-in Guide, for Styles 51800 BA, BB -----	8
3	51292 D	Tension Thread Eyelet, for Styles 51400 BE, 51700 BU --	4
	51292 D	Tension Thread Eyelet, for Styles 51800 BA, BB -----	8
4	666-28	Eyelet Locking Ring, for Styles 51400 BE, 51700 BU -----	8
	668-28	Eyelet Locking Ring, for Styles 51800 BA, BB -----	16
5	668-25	Eyelet, for Styles 51400 BE, 51700 BU -----	8
	668-25	Eyelet, for Styles 51800 BA, BB -----	16
6	51292 A	Ferrule, for Styles 51400 BE, 51700 BU -----	4
	51292 A	Ferrule, for Styles 51800 BA, BB -----	8
7	51292 G	Tension Post, for Styles 51400 BE, 51700 BU -----	4
	51292 G	Tension Post, for Styles 51800 BA, BB -----	8
8	109	Tension Disc, for Styles 51400 BE, 51700 BU -----	8
	109	Tension Disc, for Styles 51800 BA, BB -----	16
9	51292 F-1	Tension Spring, looper, for Style 51400 BE -----	2
	51292 F-2	Tension Spring, looper, for Style 51700 BU -----	2
	51292 F-2	Tension Spring, looper, for Styles 51800 BA, BB -----	4
10	51292 F-5	Tension Spring, needle, for Style 51400 BE -----	2
	51292 F-8	Tension Spring, needle, for Style 51700 BU -----	2
	51292 F-8	Tension Spring, needle, for Styles 51800 BA, BB -----	4
11	51292 C	Tension Nut, for Styles 51400 BE, 51700 BU -----	4
	51292 C	Tension Nut, for Styles 51800 BA, BB -----	8
12	22598 C	Screw, for Styles 51800 BA, BB -----	1
13	80557	Washer, for Styles 51800 BA, BB -----	2
14	51892	Tension Post Support, for Styles 51800 BA, BB -----	1
15	21657 AM-5	Tension Disc Separator, for Styles 51800 BA, BB -----	1
16	21657-4	Tension Disc Separator, for Styles 51400 BE, 51700 BU -	1
17	56382 X	Tension Post Support, for Styles 51400 BE, 51700 BU ---	1
18	51257 K	Presser Bar -----	1
19	531	Screw -----	1
20	51257 M	Presser Bar Connection and Guide-----	1
21	51256 C	Presser Spring, for Style 51400 BE -----	1
	53787	Presser Spring, for Styles 51700 BU, 51800 BA, BB ----	1
22	56356	Presser Spring Regulator -----	1
23	22799 T	Screw -----	1
24	240	Screw -----	1
25	53783 S	Lifter Lever Link -----	2
26	53783 L	Lifter Lever Bell Crank -----	1
27	52883 S	Lifter Lever Bell Crank Spring -----	1
28	22557 B	Screw -----	1
29	53783 M	Lifter Lever Connecting Rod -----	1
30	51283 H	Lifter Lever -----	1
31	660-207	Oil Seal Ring -----	1
31A	39552 C	Washer -----	1
32	21657 Y	Tension Release and Lifter Lever Shaft Connection -----	1
33	402	Screw -----	1
34	22596	Screw -----	1
35	21657 W	Tension Release and Lifter Lever Shaft -----	1
36	53783 N	Lifter Lever, internal -----	1
37	22537	Screw -----	1

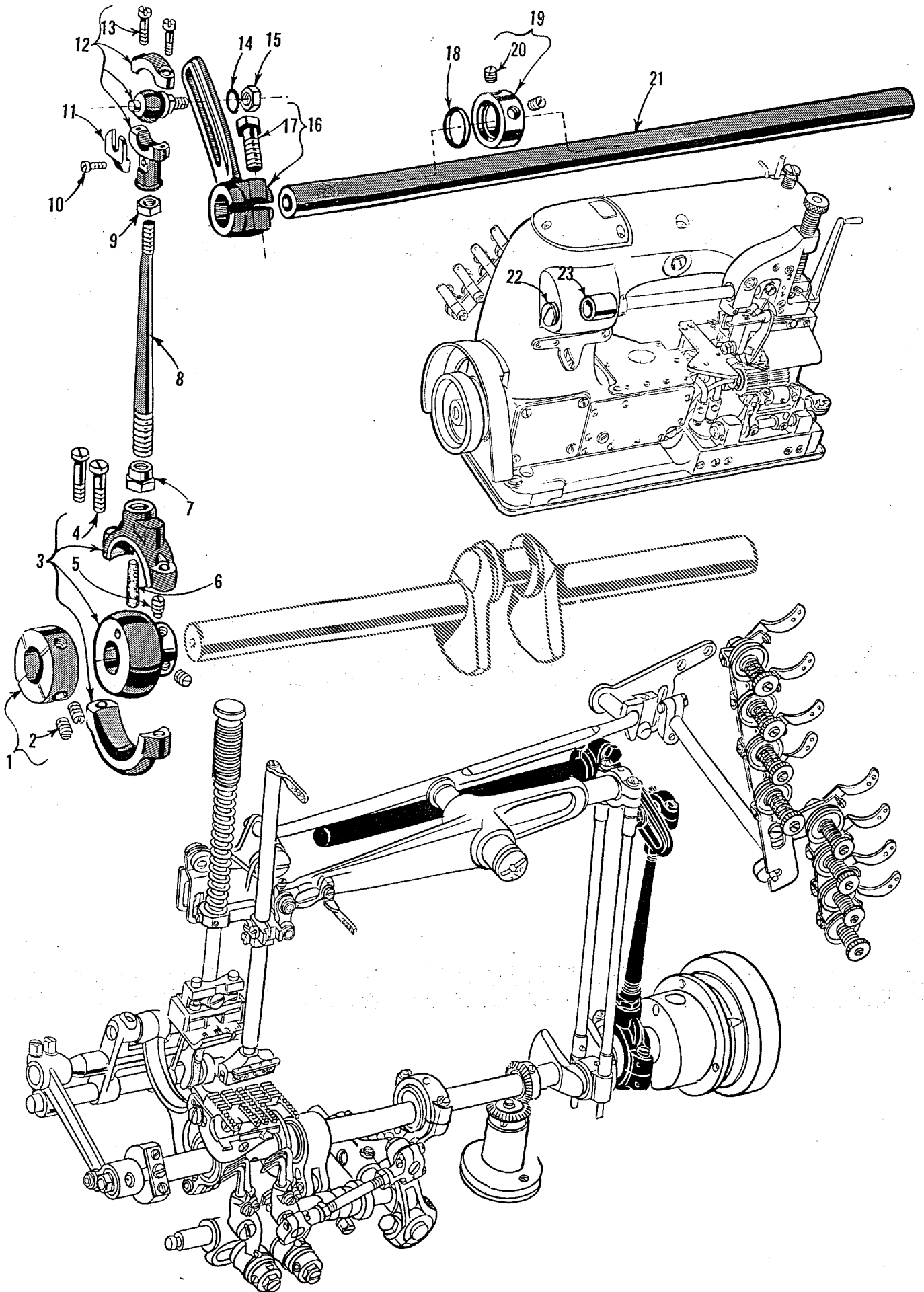

PULLER DRIVING PARTS

<u>Ref. No.</u>	<u>Part No.</u>	<u>Description</u>	<u>Amt. Req.</u>
1	9660 B	Thrust Collar -----	1
2	98	Screw-----	2
3	29126 DE	Puller Drive Eccentric Assembly -----	1
4	22587	Bearing Cap Screw -----	2
5	95	Screw-----	2
6	666-53	Lubricating Felt-----	1
7	15430 D	Nut, right thread -----	1
8	53716	Connecting Rod-----	1
9	269	Nut, left thread -----	1
10	22747	Screw-----	1
11	41255 B	Ball Stud Guide Fork-----	1
12	52854	Puller Driving Connecting Rod Ball Joint-----	1
13	22729 C	Bearing Cap Screw -----	2
14	454 A	Washer-----	1
15	258	Nut -----	1
16	53752	Puller Driving Shaft Segment Lever -----	1
17	22811	Screw-----	1
18	660-202	Oil Seal Ring-----	1
19	52849 C	Thrust Collar -----	1
20	95	Screw-----	2
21	54249	Puller Driving Shaft -----	1
22	22539 D	Plug Screw -----	1
23	53790 A	Puller Driving Shaft Bushing-----	1

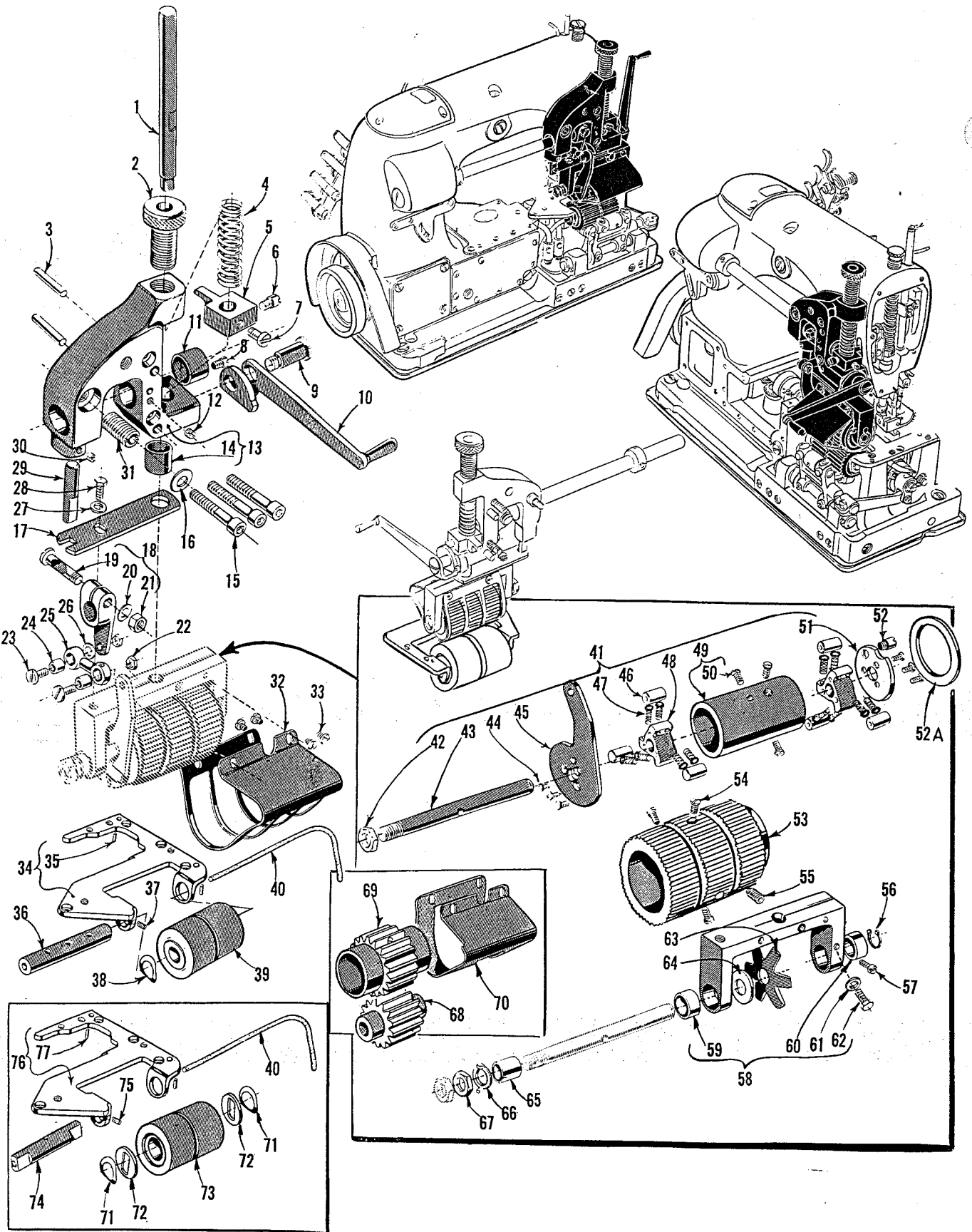

FEED ROLLER AND PULLER CLUTCH PARTS

Ref. No.	Part No.	Description	Amt. Req.
1	54277 J	Feed Roller Presser Bar-----	1
2	54277 C	Feed Roller Presser Spring Regulator-----	1
3	667 D-24	Dowel Pin-----	2
4	54277 B	Feed Roller Presser Spring-----	1
* 5	54277 G	Feed Roller Presser Bar Collar-----	1
* 6	22845 C	Screw-----	1
7	22517	Screw-----	1
8	33174 B	Stop Screw-----	1
9	22854 D	Screw-----	1
10	54277 K	Feed Roller Lifter/Lever-----	1
11	54249 B	Clutch Driving Shaft Bushing, left-----	1
12	89	Screw-----	1
13	54277 HA	Feed Roller Mounting Bracket-----	1
14	43245 N	Bushing-----	1
15	22653 D-24	Screw-----	3
16	43137 E	Washer-----	1
17	54278 T	Feed Roller Yoke Guide-----	1
18	54249 C	Clutch Driving Lever-----	1
19	55235 D	Locking Stud-----	1
20	6042 A	Washer-----	1
21	55235 E	Nut-----	1
22	12934 A	Nut-----	2
23	22757	Screw-----	2
24	51771	Ferrule-----	2
25	51770-56	Connection Link-----	1
26	54249 D	Washer-----	1
27	8372 A	Washer-----	1
28	22792 A	Screw-----	1
29	54278 B	Guide Stud-----	1
30	89	Screw-----	1
31	22899	Screw-----	1
32	54278 X	Feed Roller Guard, for Styles 51700 BU, 51800 BA, BB-----	1
33	22704	Screw-----	4
34	51480 D	Throat Plate and Lower Feed Roller Support, for Styles 51400 BE, 51800 BA, BB-----	1
35	51280 J	Dowel Pin-----	2
36	54276 L	Lower Feed Roller Shaft, for Styles 51400 BE, 51800 BA, BB-----	1
37	22733	Screw, for Styles 51400 BE, 51800 BA, BB-----	1
38	660-223	Spring Washer, for Styles 51400 BE, 51800 BA, BB-----	1
39	54276 A	Lower Feed Roller, rubber, for Styles 51800 BA, BB-----	1
40	666-153	Oil Wick, for No. 54276 L-----	1
41	29476 GG	Feed Roller Clutch Assembly-----	1
42	11638 M	Nut-----	1
43	54274 G	Clutch Shaft-----	1
44	605 A	Screw-----	6
45	54274 K	Clutch Driving Lever-----	1
46	54274 L	Roller-----	6
47	29480 KP	Clutch Spring and Cap Assembly-----	12
48	54274 H	Clutch Disc-----	2
49	54274 F	Clutch Barrel-----	1
50	538	Screw-----	3
51	54274 J	Clutch Plate-----	1
52	22892 D	Screw-----	1
52A	54274 R	Washer, fiber, for Styles 51700 BU, 51800 BA, BB-----	1
53	54275 C	Upper Feed Roller, steel toothed, for Styles 51700 BU, 51800 BA, BB-----	1
54	538	Screw-----	3
55	22894 H	Screw-----	1
56	660-208	Locking Ring-----	1
57	77 B	Screw-----	1
58	54278 S	Upper Feed Roller Yoke-----	1
59	54278 U	Bushing, right-----	1
60	54278 V	Bushing, left-----	1
61	51235 G	Washer-----	1
62	T38	Screw-----	1
63	54274 N	Clutch Tension Spring-----	1
64	54274 P	Thrust Washer-----	1
65	54278 W	Feed Roller Yoke Bearing Sleeve-----	1
66	54278 Y	Driving Washer-----	1
67	11638 M	Nut-----	1
68	51476 A	Lower Feed Roller, bakelite, for Style 51400 BE-----	1
69	51475 A	Upper Feed Roller, bakelite, for Style 51400 BE-----	1
70	54278 AB	Feed Roller Guard, for Style 51400 BE-----	1
71	54276 W	Spring Washer, for Style 51700 BU-----	2
72	51776 C	Washer, for Style 51700 BU-----	2
73	51776 A	Lower Feed Roller, rubber, for Style 51700 BU-----	1
74	51776 B	Puller Roller Shaft, for Style 51700 BU-----	1
75	73 C	Screw, for Style 51700 BU-----	1
76	51780 B	Throat Plate and Lower Feed Roller Support, for Style 51700 BU-----	1
77	51280 J	Dowel Pin-----	2

* Replaced by No. 54277 M, on late model machines.

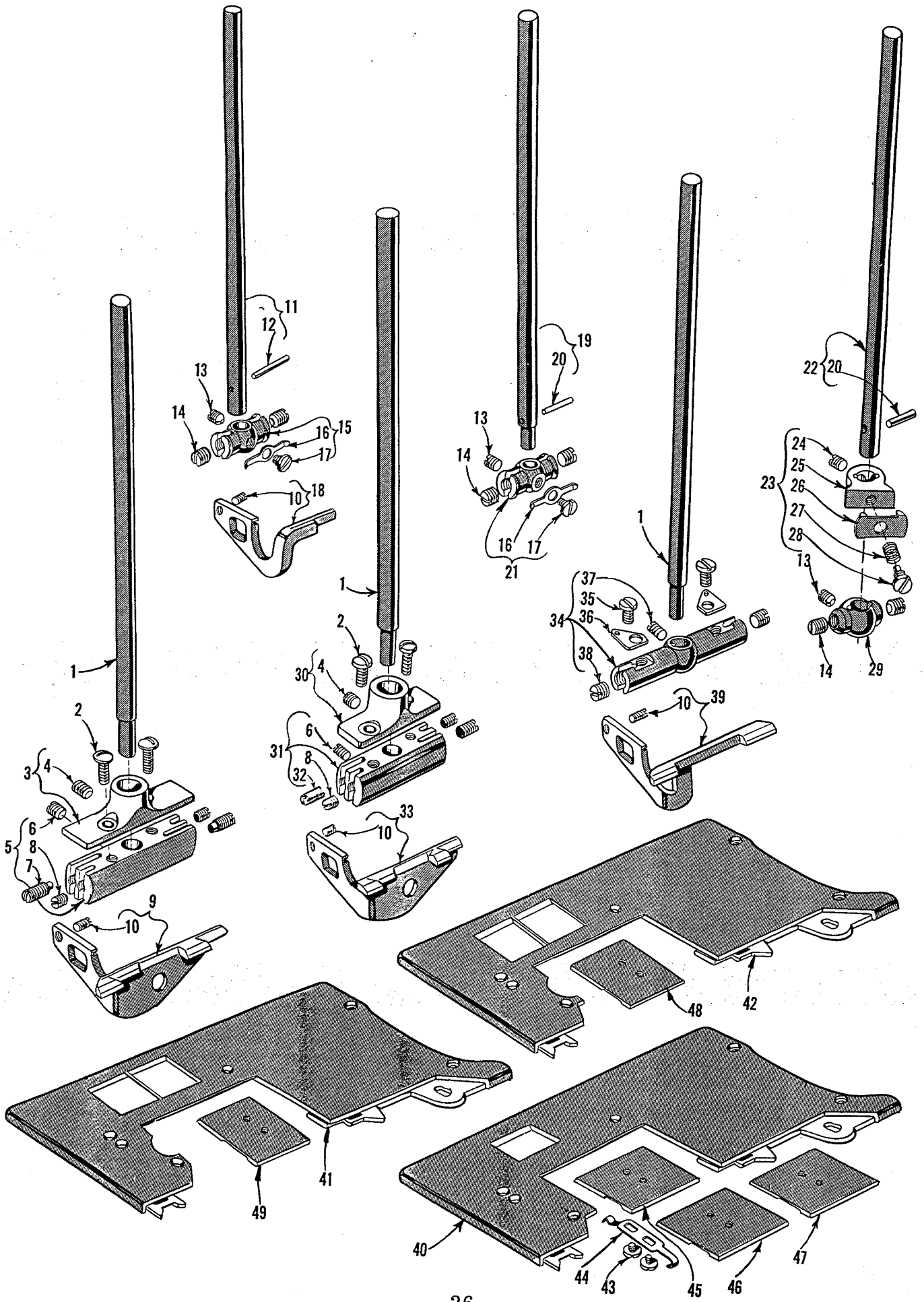

NEEDLE BARS, NEEDLE HOLDERS, NEEDLE GUARDS, CLOTH PLATES
AND CLOTH PLATE COVERS

Ref. No.	Part No.	Description	Amt. Req.
1	51817 A	Needle Bar, marked "DL", for Styles 51700 BU, 51800 BA, BB-----	1
2	22849	Screw, for Nos. 51833, 51833 A-----	2
3	51833 A	Needle Stop Plate, for Nos. 16-64-16, 16-76-16 gauge on Styles 51800 BA, BB-----	1
4	88	Screw, for Nos. 51833, 51833 A-----	1
5	51818-16-64-16	Needle Holder, for No. 16-64-16 gauge on Styles 51800 BA, BB-----	1
	51818-16-76-16	Needle Holder, for No. 16-76-16 gauge on Styles 51800 BA, BB-----	1
6	22894 P	Screw-----	1
7	22575	Screw, for Nos. 51818-16-64-16, 51818-16-76-16-----	2
8	22565 C	Screw-----	2
9	51825 C	Needle Guard, for No. 16-76-16 gauge on Styles 51800 BA, BB-----	1
	51825 CA	Needle Guard, for No. 16-64-16 gauge on Styles 51800 BA, BB-----	1
10	22801	Screw, for Nos. 51425 E, 51725 C, 51825 B, 51825 C-----	1
11	51417 D	Needle Bar, marked "DE", for No. 24 gauge on Style 51400 BE-----	1
12	50 J-40	Stop Pin-----	1
13	89	Screw-----	1
14	98	Screw-----	2
15	7018 E-5 1/2	Needle Holder, marked "G-5 1/2", for No. 24 gauge on Style 51400 BE-----	1
16	7040-6	Thread Guide-----	1
17	187 B	Screw-----	1
18	51425 E	Needle Guard, for Style 51400 BE-----	1
19	56517 B-18	Needle Bar, marked "EU", for No. 18 gauge on Style 51400 BE-----	1
20	50 J-16	Stop Pin, for Nos. 15417 E-16 and 51417 F-----	1
21	7018 E-5	Needle Holder, marked "G-5", for No. 18 gauge on Style 51400 BE---	1
22	56517 B-16	Needle Bar, marked "ET", for No. 16 gauge on Style 51400 BE-----	1
23	1287	Needle Bar Thread Nipper, for Style 51400 BE-----	1
24	88	Screw-----	1
25	1288	Needle Bar Thread Nipper Collar-----	1
26	57 WB	Needle Bar Thread Nipper Spring Plate-----	1
27	57 WC	Needle Bar Thread Nipper Spring-----	1
28	57 WD	Screw-----	1
29	51418-16	Needle Holder, marked "D-16", for No. 16 gauge on Style 51400 BE--	1
30	51833	Needle Stop Plate, for Nos. 12-56-12, 12-64-12 gauge on Styles 51800 BA, BB-----	1
31	51818-12-56-12	Needle Holder, for No. 12-56-12 gauge on Styles 51800 BA, BB-----	1
	51818-12-64-12	Needle Holder, for No. 12-64-12 gauge on Styles 51800 BA, BB-----	1
32	22565 D	Screw, for Nos. 51818-12-56-12, 51818-12-64-12-----	2
33	51825 B	Needle Guard, for Nos. 12-56-12, 12-64-12 gauge on Styles 51800 BA, BB-----	1
34	51718 A-96	Needle Holder, for Style 51700 BU-----	1
35	22513 B	Screw-----	2
36	51718 B-64	Needle Stop-----	2
37	22894 P	Screw-----	1
38	98	Screw-----	2
39	51725 C	Needle Guard, for Style 51700 BU-----	1
40	51401 S	Cloth Plate, for Style 51400 BE-----	1
41	51801 A	Cloth Plate, for Styles 51800 BA, BB-----	1
42	51701 V	Cloth Plate, for Style 51700 BU-----	1
43	12986 B	Screw-----	2
44	51281 AF	Cloth Plate Cover Spring-----	1
45	51281 AG-148	Cloth Plate Cover, for No. 24 gauge on Style 51400 BE-----	1
46	51281 AG-150	Cloth Plate Cover, for No. 16 gauge on Style 51400 BE-----	1
47	51281 AG-144	Cloth Plate Cover, for No. 18 gauge on Style 51400 BE-----	1
48	51281 AG-103	Cloth Plate Cover, for Style 51700 BU-----	1
49	51281 AG- 99	Cloth Plate Cover, for Styles 51800 BA, BB-----	1

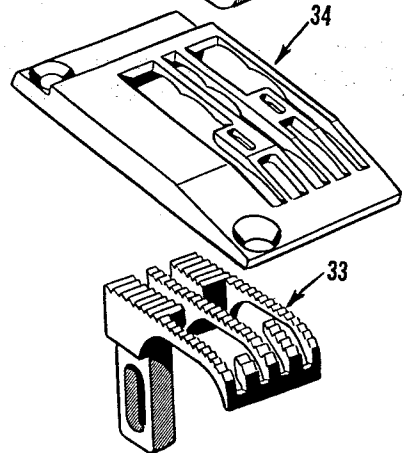
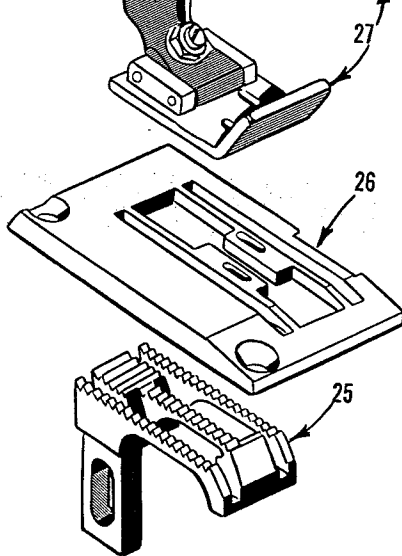
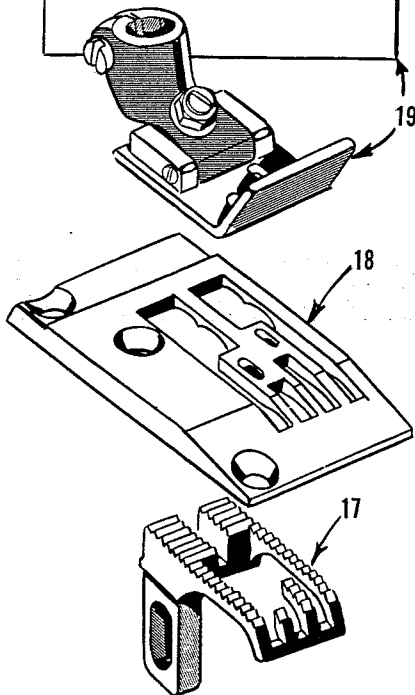
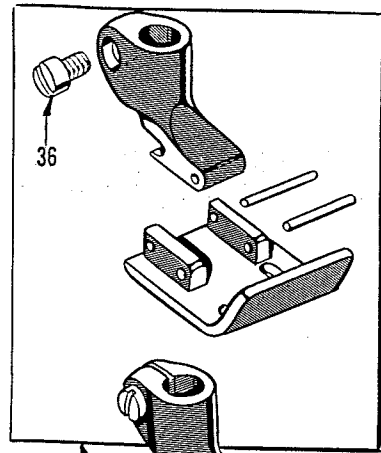
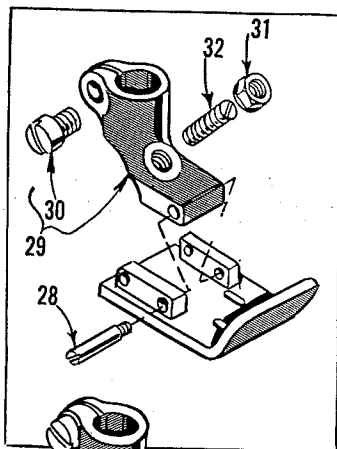
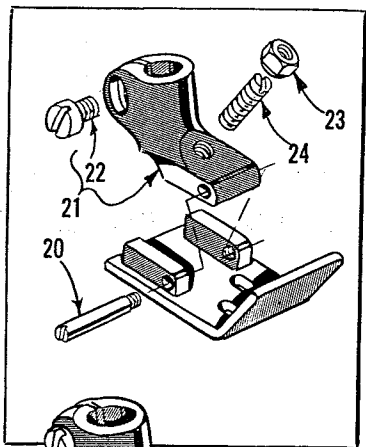
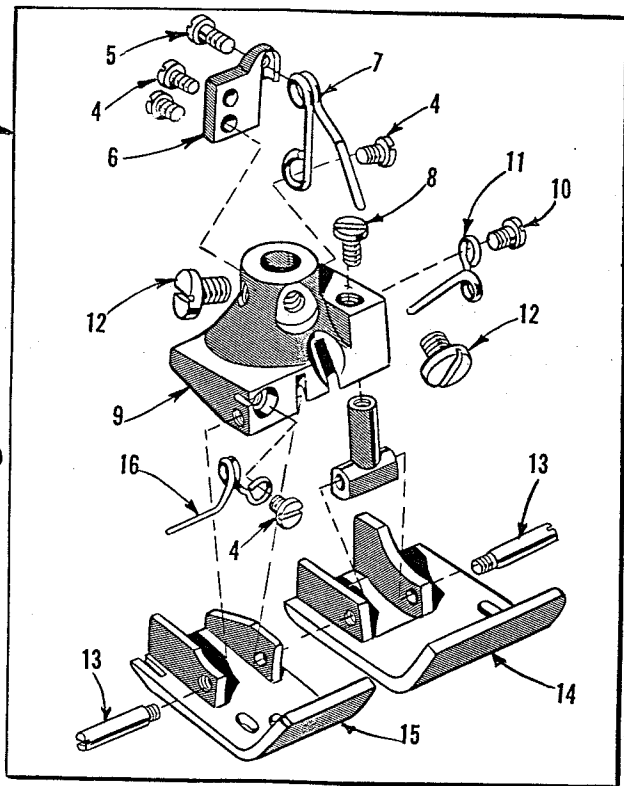
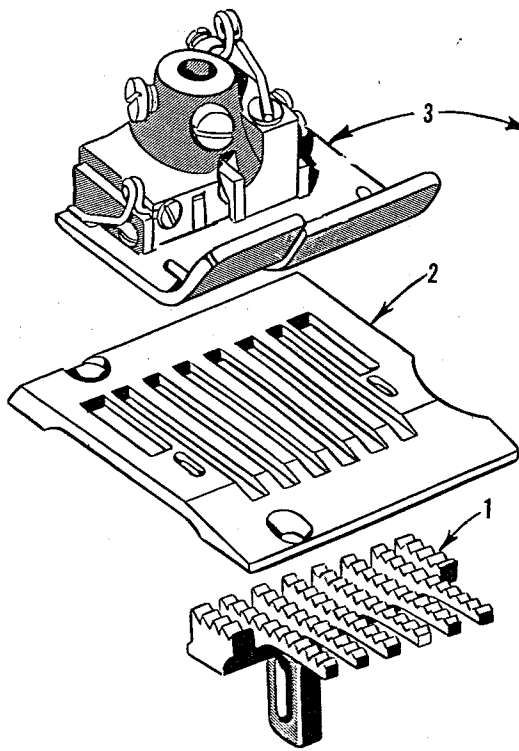

FEED DOGS, THROAT PLATES, PRESSER FEET

<u>Ref. No.</u>	<u>Part No.</u>	<u>Description</u>	<u>Amt. Req.</u>
1	16505-96	Feed Dog, for Style 51700 BU-----	1
2	16524 B-96	Throat Plate, for Style 51700 BU-----	1
3	51720 F-96	Presser Foot, for Style 51700 BU-----	1
4	605	Screw-----	4
5	605 A	Yielding Section Spring Adjusting Screw -----	1
6	65-96	Spring Holder-----	1
7	16194	Yielding Section Spring -----	1
8	87 U	Yielding Section Screw-----	1
9	51730 G	Shank -----	1
10	604	Screw-----	1
11	16241	Hinge Spring, right side -----	1
12	22570	Clamp Screw -----	2
13	22799 S	Hinge Screw -----	2
14	51730 J	Presser Foot Bottom, right-----	1
15	51730 H	Presser Foot Bottom, left -----	1
16	16241 A	Hinge Spring, left side-----	1
17	7405 U-4 1/2	Feed Dog, for No. 16 gauge on Style 51400 BE----	1
18	7528 H-4 1/2	Throat Plate, for No. 16 gauge on Style 51400 BE-	1
19	7420 AG-4 1/2	Presser Foot, for No. 16 gauge on Style 51400 BE-----	1
20	22799 E	Hinge Screw -----	1
21	51430 D	Shank -----	1
22	91	Clamp Screw -----	1
23	51430 F	Adjusting Nut -----	1
24	22840 A	Adjusting Screw-----	1
25	7405 AG-5	Feed Dog, for No. 18 gauge on Style 51400 BE----	1
26	7424 AG-5	Throat Plate, for No. 18 gauge on Style 51400 BE-	1
27	7420 AG-5	Presser Foot, for No. 18 gauge on Style 51400 BE-----	1
28	22799 E	Hinge Screw -----	1
29	51430 D	Shank -----	1
30	91	Clamp Screw -----	1
31	51430 F	Adjusting Nut -----	1
32	22840 A	Adjusting Screw-----	1
33	7405 AF-5 1/2	Feed Dog, for No. 24 gauge, on Style 51400 BE---	1
34	7424 AF-5 1/2	Throat Plate, for No. 24 gauge, on Style 51400 BE-----	1
35	7420 AG-5 1/2	Presser Foot, for No. 24 gauge, on Style 51400 BE-----	1
36	91	Clamp Screw -----	1

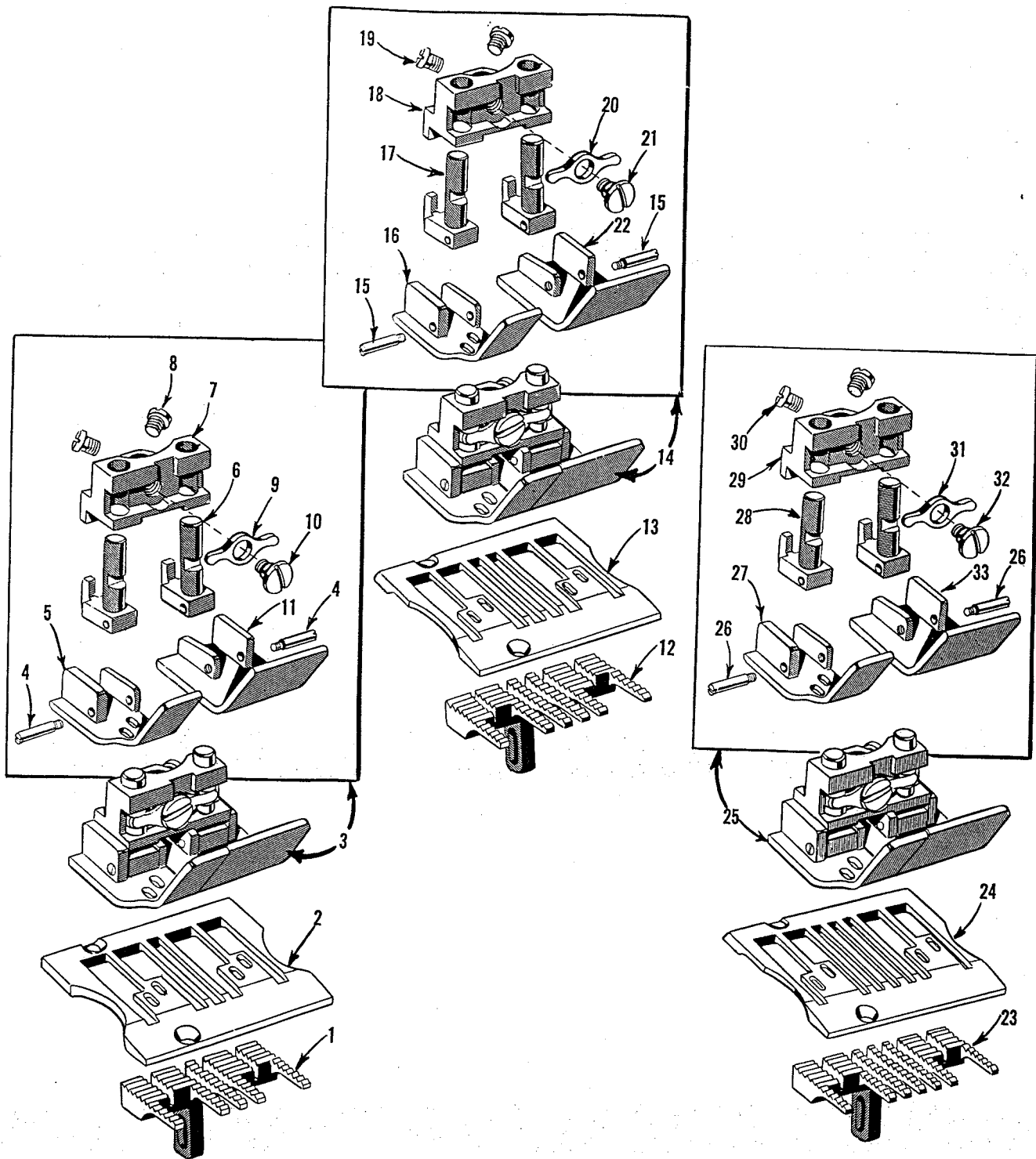

FEED DOGS, THROAT PLATES, PRESSER FEET

<u>Ref. No.</u>	<u>Part No.</u>	<u>Description</u>	<u>Amt. Req.</u>
1	51805-12-56-12	Feed Dog, for No. 12-56-12 gauge on Styles 51800 BA, BB-----	1
	51805-12-64-12	Feed Dog, for No. 12-64-12 gauge on Styles 51800 BA, BB-----	1
2	51824-12-56-12	Throat Plate, for No. 12-56-12 gauge on Styles 51800 BA, BB-----	1
	51824-12-64-12	Throat Plate, for No. 12-64-12 gauge on Styles 51800 BA, BB-----	1
3	51820-12-56-12	Presser Foot, for No. 12-56-12 gauge on Styles 51800 BA, BB-----	1
	51820-12-64-12	Presser Foot, for No. 12-64-12 gauge on Styles 51800 BA, BB-----	1
4	22799 S	Hinge Screw -----	2
5	51830 B-12-56-12	Presser Foot Bottom, left, for No. 12-56-12 gauge -----	1
	51830 B-12-64-12	Presser Foot Bottom, left, for No. 12-64-12 gauge -----	1
6	51830 C	Plunger -----	2
7	51830	Shank -----	1
8	22584	Screw -----	2
9	51830 D	Equalizer-----	1
10	22758	Screw -----	1
11	51830 A-12-56-12	Presser Foot Bottom, right, for No. 12-56-12 gauge -----	1
	51830 A-12-64-12	Presser Foot Bottom, right, for No. 12-64-12 gauge -----	1
12	51805-16-64-16	Feed Dog, for No. 16-64-16 gauge on Styles 51800 BA, BB-----	1
13	51824-16-64-16	Throat Plate, for No. 16-64-16 gauge on Styles 51800 BA, BB-----	1
14	51820-16-64-16	Presser Foot, for No. 16-64-16 gauge on Styles 51800 BA, BB-----	1
15	22799 S	Hinge Screw -----	2
16	51830 B-16-64-16	Presser Foot Bottom, left, for No. 16-64-16 gauge -----	1
17	51830 C	Plunger -----	2
18	51830	Shank -----	1
19	22584	Screw -----	2
20	51830 D	Equalizer-----	1
21	22758	Screw -----	1
22	51830 A-16-64-16	Presser Foot Bottom, right, for No. 16-64-16 gauge -----	1
23	51805-16-76-16	Feed Dog, for No. 16-76-16 gauge on Styles 51800 BA, BB-----	1
24	51824-16-76-16	Throat Plate, for No. 16-76-16 gauge on Styles 51800 BA, BB-----	1
25	51820-16-76-16	Presser Foot, for No. 16-76-16 gauge on Styles 51800 BA, BB-----	1
26	22799 S	Hinge Screw -----	2
27	51830 B-16-76-16	Presser Foot Bottom, left, for No. 16-76-16 gauge -----	1
28	51830 C	Plunger -----	2
29	51830	Shank -----	1
30	22584	Screw -----	2
31	51830 D	Equalizer-----	1
32	22758	Screw -----	1
33	51830 A-16-76-16	Presser Foot Bottom, right, for No. 16-76-16 gauge -----	1

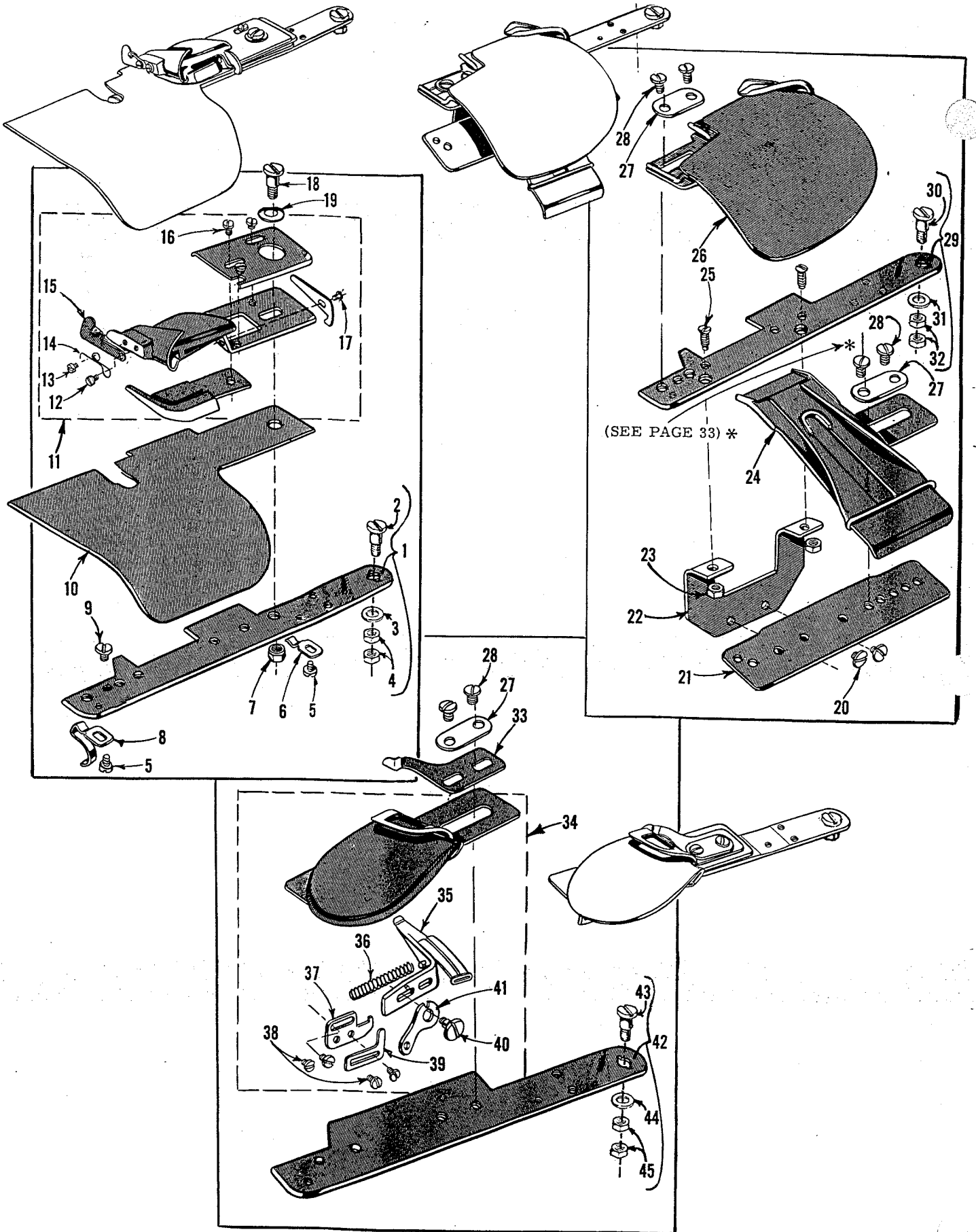

ATTACHMENTS AND ATTACHING BRACKETS

<u>Ref. No.</u>	<u>Part No.</u>	<u>Description</u>	<u>Amt. Req.</u>
1	51864	Folder Mounting Bracket, for Nos. 12-56-12, 12-64-12, 16-64-16 gauge on Style 51800 BA, BB -----	1
	K72393	Folder Mounting Bracket, for No. 16-76-16 gauge on Styles 51800 BA, BB -----	1
2	22504 A	Pivot Screw -----	1
3	28577	Washer -----	1
4	9937	Nut -----	2
5	12986 B	Screw -----	2
6	54264 B	Spring -----	1
7	1280	Nut, for 22854 on Styles 51800 BA, BB -----	1
8	54264 C	Spring, with finger projection -----	1
9	25 C	Screw, for 23325 S -----	1
10	23325 S	Cloth Guard, for Styles 51800 BA, BB -----	1
11	23325 R-96-3/16	Upper Folder, for turning edge of bib downwardly, 3/16 inch capacity, 3/8 inch fold, for Styles 51800 BA, BB -----	1
12	22561	Screw -----	1
13	187 A	Screw -----	1
14	23325 D	Spring -----	1
15	23325 M	Yielding Guide -----	1
16	22570	Screw -----	3
17	87 U	Screw -----	1
18	22854	Pivot Screw, for 23325 S on Styles 51800 BA, BB -----	1
19	HA86 B	Spring Washer, for 22854 on Styles 51800 BA, BB -----	1
20	22730	Screw, for 23293 R -----	2
21	23293 R	Folder Support, for Style 51700 BU -----	1
22	23293 S	Folder Support Bracket, for Style 51700 BU -----	1
23	18	Nut, for 80 -----	2
24	23293 P-96	Lower Strip Folder, for attaching waistbands to trousers, 3/64 inch capacity, uses 2 1/2 inch strip, finishes 1 3/4 inch wide, for Style 51700 BU -----	1
25	80	Screw, for 23293 S -----	2
26	23325 T-120	Upper Folder, for turning edge of garment downwardly, 5/32 inch capacity, 3/8 inch fold, for Style 51700 BU -----	1
27	23425 V	Washer Plate -----	1
28	25 C	Screw -----	2
29	51764	Folder Mounting Bracket, for Style 51700 BU -----	1
30	22504 A	Pivot Screw -----	1
31	28577	Washer -----	1
32	9937	Nut -----	2
33	7403 P	Supplemental Edge Guide, for Style 51400 BE -----	1
34	23386 E-()	Reverse Hemmer, 1/16 inch capacity, 3/8 inch width of elastic, with shiftable elastic guide, for Style 51400 BE (See Chart Below)---	1
35	23386 F	Shiftable Elastic Guide -----	1
36	75080 C	Spring -----	1
37	23386 H	Shiftable Elastic Guide Stop, right -----	1
38	22513	Screw -----	4
39	23386 J	Shiftable Elastic Guide Stop, left -----	1
40	22787 B	Screw -----	1
41	23386 G	Shiftable Elastic Guide Lever -----	1
42	51464	Folder Mounting Bracket, for Style 51400 BE -----	1
43	22504 A	Pivot Screw -----	1
44	28577	Washer -----	1
45	9937	Nut -----	2

<u>ATTACHMENT NO.</u>	<u>WIDTH OF HEM</u>	<u>MACHINE GAUGE NUMBER</u>	<u>HEADING</u>
23386 E-7/16	7/16"	16	1/8"
23386 E-15/32	15/32"	18	1/8"
23386 E-1/2	1/2"	16	3/16"
	1/2"	18	3/16"
23386 E-9/16	9/16"	16	1/4"
23386 E-19/32	19/32"	18	1/4"
23386 E-5/8	5/8"	24	1/8"

* NOTE: Two No. 28577 washers are required for use with No. 23293 P-96 folder.

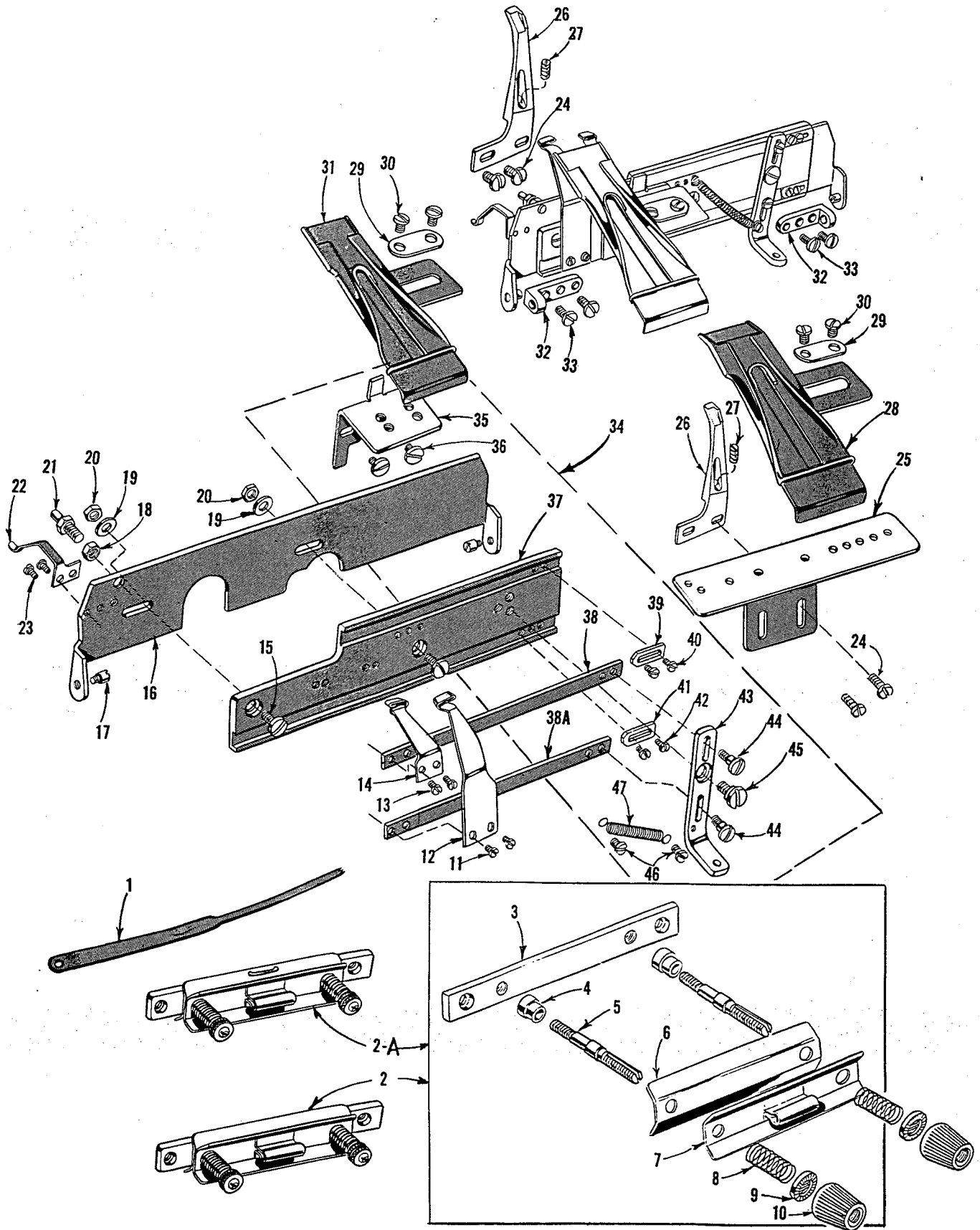

ATTACHMENTS, STRIP TENSIONS AND COLLAPSING MECHANISM

Ref. No.	Part No.	Description	Amt. Req.
1	23279 D	Folder Threader, for Style 51700 BU-----	1
2	21182 N	Strip Tension Assembly, for Styles 51700 BU, 51800 BA, BB-----	1
2A	21182 T	Strip Tension Assembly, for Style 51400 BE-----	1
3	21182 P	Strip Tension Base-----	1
4	11261 B	Tension Post Ferrule-----	2
5	56392 E	Tension Post-----	2
*6	21182 L	Strip Tension Plate, inner, for 21182 N-----	1
7	21182 K	Strip Tension Plate, outer-----	1
8	110-3	Tension Spring-----	2
9	39592 AK	Tension Spring Ferrule-----	2
10	39592 Z	Tension Nut-----	2
11	90	Screw, for No. 23454 H-----	2
12	23454 H	Strip Collapsing Finger, left, for Style 51800 BA-----	1
13	90	Screw, for No. 23454 G-----	2
14	23454 G	Strip Collapsing Finger, right, for Style 51800 BA-----	1
15	22548	Screw, for No. 23454 on Style 51800 BA-----	2
16	23454 J	Collapsing Device Mounting Bracket, for Style 51800 BA-----	1
17	402	Hinge Pin, for No. 23454 J-----	2
18	258	Nut, for No. 4952 C-----	1
19	21657 E	Washer, for No. 22548-----	2
20	12538	Nut, for No. 22548-----	2
21	4952 C	Stud Stop for Collapsing Mechanism, for Style 51800 BA-----	1
22	23454 L	Strip Collapsing Device Mounting Bracket Latch Spring, for Style 51800 BA-----	1
23	90	Screw, for No. 23454 L-----	2
24	22548	Screw, for No. 51880 on Styles 51800 BA, BB-----	2
25	23293 N	Folder Support, for Style 51800 BB-----	1
26	51880	Supplementary Throat Plate Support, for Styles 51800 BA, BB-----	1
27	12935 A	Adjusting Screw, for No. 51880-----	1
28	23293 D-80	Lower Strip Folder, for attaching bibs to overalls, 1/16 inch capacity, uses 2 inch strip, finishes 1 3/8 inch wide, for No. 12-56-12 gauge on Style 51800 BB-----	1
	23293 D-88	Lower Strip Folder, for attaching bibs to overalls, 1/16 inch capacity, uses 2 1/8 inch strip, finishes 1 1/2 inch wide, for No. 12-64-12 gauge on Style 51800 BB-----	1
	23293 D-96	Lower Strip Folder, for attaching bibs to overalls, 1/16 inch capacity, uses 2 1/4 inch strip, finishes 1 5/8 inch wide, for No. 16-64-16 gauge on Style 51800 BB-----	1
	23293 D-108	Lower Strip Folder, for attaching bibs to overalls, 1/16 inch capacity, uses 2 1/2 inch strip, finishes 1 13/16 inch wide, for No. 16-76-16 gauge on Style 51800 BB-----	1
29	23425 V	Washer Plate-----	1
30	25 C	Screw-----	2
31	23293 M-80	Lower Strip Folder, for attaching bibs to overalls, 3/64 inch capacity, uses 2 1/8 inch strip, finishes 1 7/16 inch wide, for No. 12-56-12 gauge on Style 51800 BA-----	1
	23293 M-88	Lower Strip Folder, for attaching bibs to overalls, 3/64 inch capacity, uses 2 1/16 inch strip, finishes 1 9/16 inch wide, for No. 12-64-12 gauge on Style 51800 BA-----	1
	23293 M-96	Lower Strip Folder, for attaching bibs to overalls, 3/64 inch capacity, uses 2 1/4 inch strip, finishes 1 11/16 inch wide, for No. 16-64-16 gauge on Style 51800 BA-----	1
	23293 M-108	Lower Strip Folder, for attaching bibs to overalls, 3/64 inch capacity, uses 2 1/2 inch strip, finishes 1 7/8 inch wide, for No. 16-76-16 gauge on Style 51800 BA-----	1
32	23454 M	Strip Collapsing Device Mounting Bracket Hinge Block, for Style 51800 BA-----	2
33	22548	Screw, for No. 23454 M-----	4
34	23454	Strip Collapsing Device, for Style 51800 BA-----	1
35	23454 B	Strip Collapsing Device Folder Support-----	1
36	255	Screw-----	2
37	23454 A	Strip Collapsing Device Frame-----	1
38	23454 E	Strip Collapsing Device Finger Operating Arm, lower-----	1
38A	23454 D	Strip Collapsing Device Finger Operating Arm, upper-----	1
39	23454 F	Strip Collapsing Device Finger Operating Arm Stop, adjustable-----	1
40	90	Screw-----	2
41	23454 F	Strip Collapsing Device Finger Operating Arm Stop, adjustable-----	1
42	90	Screw-----	2
43	23454 C	Strip Collapsing Device Operating Lever-----	1
44	HA65 L	Screw-----	2
45	22715	Screw-----	1
46	90	Screw-----	2
47	9471	Spring-----	1

* No part number available for Assembly No. 21182 T

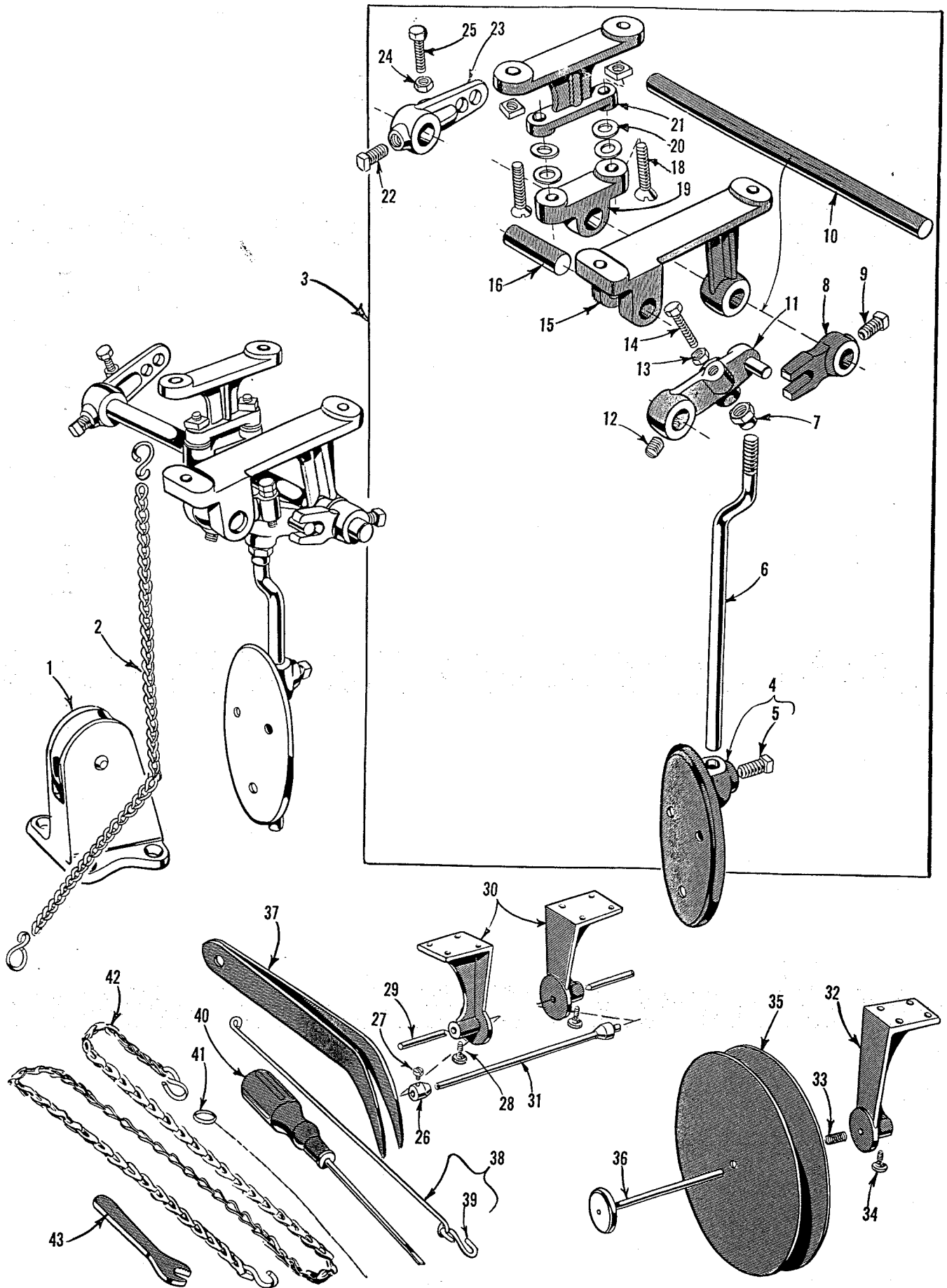

ACCESSORIES

Ref. No.	Part No.	Description	Amt. Req.
1	660-167	Idler Pulley, for Style 51800 BA-----	1
2	21693 L	Knee Press Chain, for Style 51800 BA -----	1
3	21693 A	Knee Press Assembly, for collapsing mechanism on Style 51800 BA -----	1
4	21685	Knee Press Plate-----	1
5	69 FD	Set Screw -----	1
6	21693 J	Knee Press Plate Rod-----	1
7	15430 D	Nut -----	1
8	21693 F	Knee Press Interlocking Lever, left -----	1
9	69 FD	Set Screw-----	1
10	21693 B	Knee Press Shaft -----	1
11	21693 G	Knee Press Interlocking Lever, right-----	1
12	22622	Set Screw-----	1
13	34	Nut -----	1
14	12993 A	Stop Screw-----	1
15	21693 C	Knee Press Shaft Bracket, front -----	1
16	21693 H	Knee Press Interlocking Lever Shaft-----	1
18	650-10	Stove Bolt -----	2
19	21693 D	Knee Press Shaft Bracket, rear-----	1
20	28577	Washer-----	4
21	21693 T	Knee Press Shaft Hanger Spacing Block -----	1
22	69 FD	Set Screw-----	1
23	21693 K	Knee Press Chain Lever -----	1
24	34	Nut -----	1
25	12993 A	Stop Screw-----	1
26	753	Spool Support Cone, adjustable, for Style 51400 BE----	1
27	188 D	Screw, for No. 753 -----	1
28	201 C	Screw, for No. 201 A -----	2
29	751	Center Pin, for Style 51400 BE-----	2
30	201 A	Spool Axle Support, for Style 51400 BE-----	2
31	21218	Spool Axle, for Style 51400 BE -----	1
32	21179	Lower Tape Holder Frame, for Styles 51700 BU, 51800 BA, BB-----	1
33	110-4	Tension Spring, for Style 51800 BA, BB-----	1
	110-3	Tension Spring, for Style 51700 BU -----	1
34	201 C	Thumbscrew, for Styles 51700 BU, 51800 BA, BB-----	1
35	21178 A	Tape Holder Disc, for Styles 51700 BU, 51800 BA, BB-----	2
36	21385 B	Lower Tape Holder Axle, for Styles 51700 BU, 51800 BA, BB-----	1
37	660-240	Thread Tweezers -----	1
38	51493 BC	Lifter Link-----	1
39	660-264	Hook -----	1
40	21201	Screwdriver, 9/64 inch round blade, length over-all 7 5/8 inches -----	1
41	51899	Thread Wire, for Styles 51800 BA, BB-----	1
42	421 D-28	Treadle Chain-----	1
43	21388	Wrench, single end, 3/8 inch opening -----	1

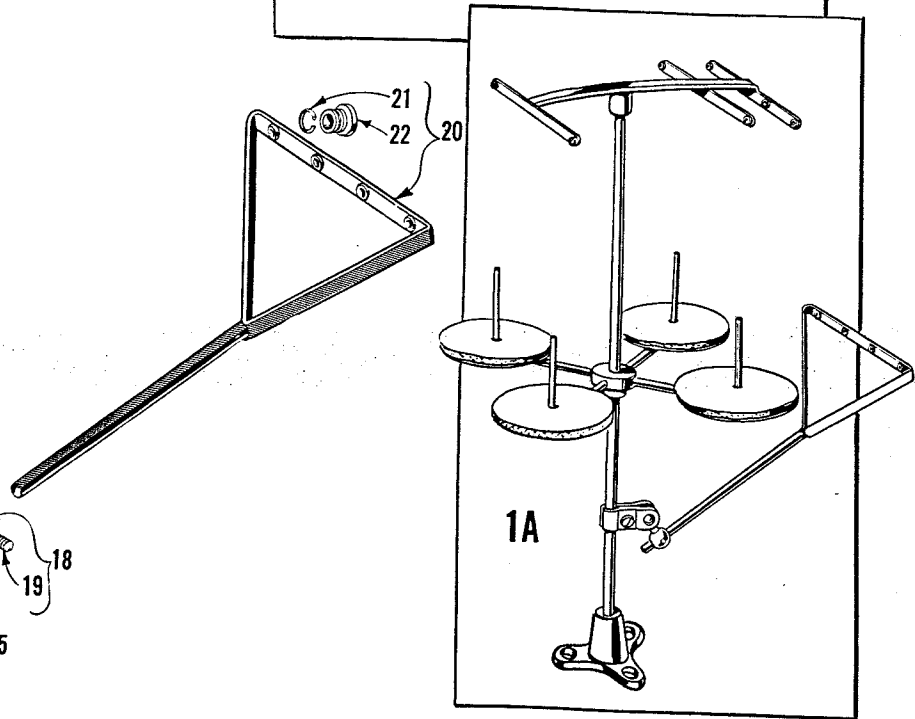
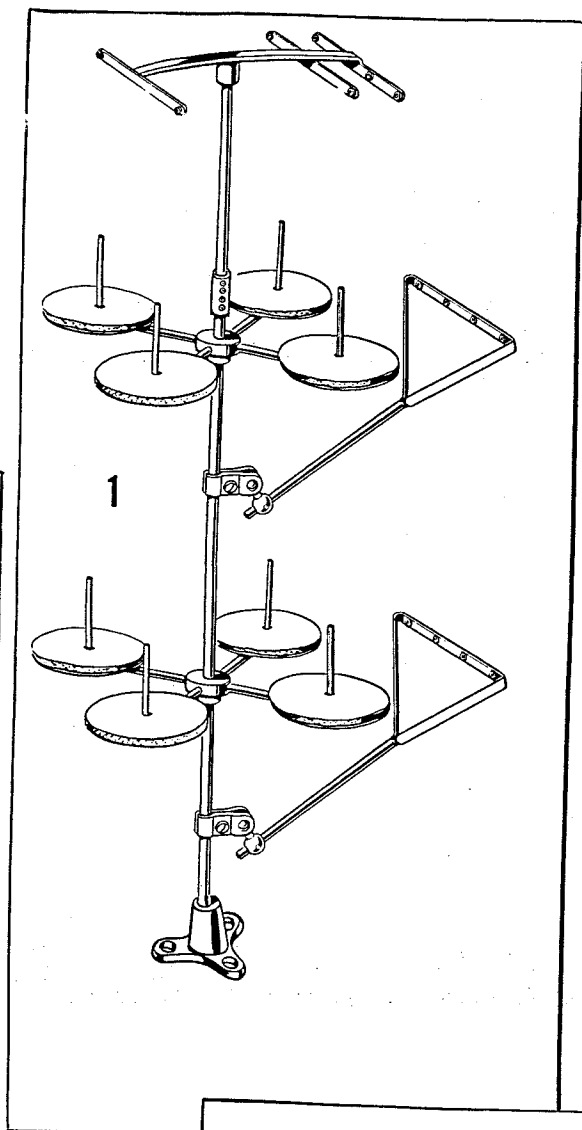
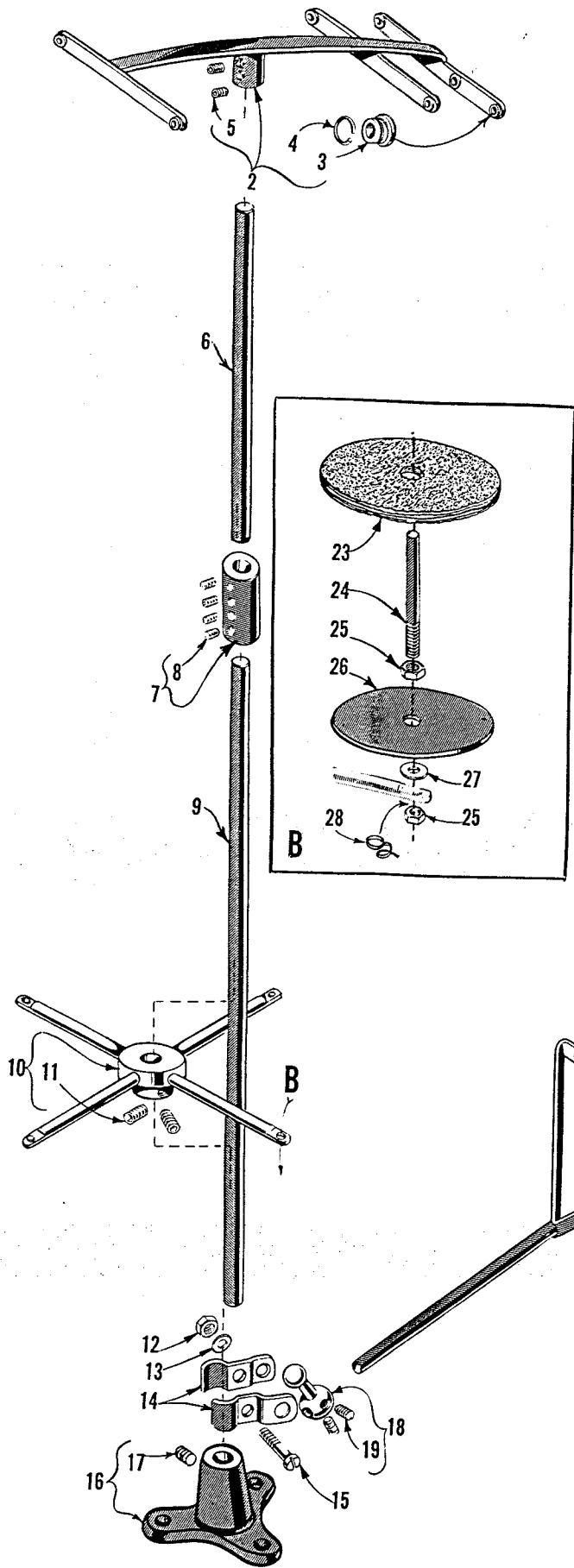

THREAD STANDS

Ref. No.	Part No.	Description	Amt. Req.
1	21101 P-8	Thread Stand, complete, for Styles 51800 BA, BB	1
1A	21101 H-4	Thread Stand, complete, for Styles 51400 BE, 51700 BU	1
2	21114 H-4	Eyelet Support	1
3	21114 L	Eyelet	8
4	21114 M	Eyelet Locking Ring	8
5	22651 CD-4	Screw	2
6	21104 B-11	Thread Stand Rod, upper, for No. 21101 P-8	1
7	21127	Coupling, for No. 21101 P-8	1
8	22651 CD-3	Screw	4
9	21104 B-24	Thread Stand Rod, lower, for No. 21101 P-8	1
		Thread Stand Rod, for No. 21101 H-4	1
10	21114 D-4	Spool Seat Support, for No. 21101 P-8	2
		Spool Seat Support, for No. 21101 H-4	1
11	22651 CD-5	Screw, for No. 21101 P-8	4
		Screw, for 21101 H-4	2
12	21104 H	Nut, for No. 21101 P-8	2
		Nut, for No. 21101 H-4	1
13	652-16	Washer, for No. 21101 P-8	2
		Washer, for No. 21101 H-4	1
14	21114 U	Lead Eyelet Ball Split Socket, for No. 21101 P-8	4
		Lead Eyelet Ball Split Socket, for No. 21101 H-4	2
15	22810	Screw, for No. 21101 P-8	2
		Screw, for No. 21101 H-4	1
16	21114 A	Thread Stand Base	1
17	22651 CD-3	Screw	1
18	21114 T	Lead Eyelet Socket Ball, for No. 21101 P-8	2
		Lead Eyelet Socket Ball, for No. 21101 H-4	1
19	22651 CD-4	Screw, for No. 21101 P-8	4
		Screw, for No. 21101 H-4	2
20	21114 S-4	Lead Eyelet, for No. 21101 P-8	2
		Lead Eyelet, for No. 21101 H-4	1
21	21114 M	Eyelet Locking Ring, for No. 21101 P-8	8
		Eyelet Locking Ring, for No. 21101 H-4	4
22	21114 L	Eyelet, for No. 21101 P-8	8
		Eyelet, for No. 21101 H-4	4
23	21104 V	Felt Pad, for No. 21101 P-8	8
		Felt Pad, for No. 21104 H-4	4
24	21114 W	Spool Pin, for No. 21101 P-8	8
		Spool Pin, for No. 21104 H-4	4
25	258 A	Nut, for No. 21101 P-8	16
		Nut, for No. 21104 H-4	8
26	21114	Spool Seat Disc, for No. 21101 P-8	8
		Spool Seat Disc, for No. 21104 H-4	4
27	652-16	Washer, for No. 21101 P-8	8
		Washer, for No. 21104 H-4	4
28	21114 AF	Eyelet, for No. 21101 P-8	8

NUMERICAL INDEX OF PARTS

<u>Part No.</u>	<u>Page No.</u>	<u>Part No.</u>	<u>Page No.</u>	<u>Part No.</u>	<u>Page No.</u>	<u>Part No.</u>	<u>Page No.</u>
WO-3	15	660-207	21	21114 U	39	22598 C	21
8	19	660-208	25	21114 W	39	22622	37
18	17, 33	660-212	15	21114 AF	39	22651 CD	39
20	11, 19	660-215	15	21127	39	22653 D	25
25 C	33, 35	660-223	25	21178 A	37	22704	25
25 S	11	660-240	37	21179	37	22715	35
27-435 Blk	15	660-264	37	21182 K	35	22729	15
27-484 Blk	15	660-614	15	21182 L	35	22729 A	13
28	19	666-53	23	21182 N	35	22729 B	13
34	37	666-65	13	21182 P	35	22729 C	23
T38	25	666-79	11	21182 T	35	22730	33
50-216 Blk	19	666-111	13	21201	37	22733	25
50-294 Blk	13	666-114	13	21212	13	22733 B	11
50-458 Blk	17	666-118	13	21218	37	22747	23
50-648 Blk	13	666-149	15, 19	BB21375 AH	11	22757	25
50-789 Blk	11	666-153	25	21385 B	37	22758	31
50 J	27	666-170	15	21388	37	22768	15, 17, 19
57 WB	27	666-179	13	21396 AG	11	22787 B	33
57 WC	27	666-201	13	21396 BJ	11	22792 A	25
57 WD	27	666-209	13	21396 BK	11	22798 A	19
65-96	29	666-214	13	21396 BP	11	22799 E	29
HA65 L	35	667 D	25	21657	21	22799 M	11
69 FD	37	668-25	21	21657 E	19, 35	22799 S	29, 31
73	17	668-28	21	21657 W	21	22799 T	21
73 C	25	719	15	21657 X	13	22801	27
75 C	15	751	37	21657 Y	21	22810	39
77	15, 19	753	37	21657 AM	21	22811	23
77 B	25	1068	11	21685	37	22811 B	17
80	11, 33	1280	17, 33	21693 A	37	22823 A	13
81	15	1287	27	21693 B	37	22823 B	13
82	19	1288	27	21693 C	37	22829	17
HA86 B	33	4761	17	21693 D	37	22834	19
87	11	4952 C	35	21693 F	37	22835	17
87 U	29, 33	6042 A	13, 25	21693 G	37	22839	11
J87 J	19	7018 E	27	21693 H	37	22839 C	11
88	17, 27	7040	27	21693 J	37	22840 A	29
88 B	17	7403 P	33	21693 K	37	22845 C	25
89	25, 27	7405 U	29	21693 L	37	22848	11
90	11, 13, 35	7405 AF	29	21693 T	37	22849	11, 27
91	29	7405 AG	29	22504 A	33	22852 A	15
93	11	7420 AG	29	22513	11, 33	22854	33
95	11, 23	7424 AF	29	22513 B	27	22854 D	25
96	17, 19	7424 AG	29	22516 B	15	22863	19
98	17, 19, 23,	7528 H	29	22517	25	22883 A	15
	27	7947	13	22519 C	19	22889 A	11
98 A	11	8372 A	25	22519 H	17	22889 C	13
109	21	9471	35	22524	11	22889 D	13
110-3	35, 37	9660 B	23	22528	19	22892 D	25
110-4	37	9937	33	22537	21	22894 C	15
158 B	11	11261 B	35	22539 D	23	22894 D	15, 19
187 A	33	11638 M	25	22539 H	13	22894 G	15
187 B	27	12538	17, 35	22541	11	22894 H	17, 25
188 D	37	12934 A	25	22541 B	11	22894 P	27
201 A	37	12935 A	35	22542	11	22899	25
201 C	37	12982	15	22548	11, 35	23279 D	35
240	21	12986 B	27, 33	22557 B	21	23293 D	35
255	35	12993 A	37	22559 A	15	23293 M	35
258	19, 23, 35	14077	17	22559 B	15	23293 N	35
258 A	13, 17, 39	15430 D	23, 37	22559 G	15	23293 P	33
269	17, 19, 23	15465 F	17	22560 B	13, 15, 19	23293 R	33
402	21, 35	16194	29	22561	33	23293 S	33
421 D	37	16241	29	22562 A	15	23325 D	33
454 A	23	16241 A	29	22564	15	23325 M	33
482	19	16505	29	22565 C	27	23325 R	33
531	13, 21	16524 B	29	22565 D	27	23325 S	33
538	19, 25	21101 H	39	22569 B	11, 13, 15	23325 T	33
604	29	21101 P	39	22570	29, 33	23386 E	33
605	29	21104 B	39	22571 A	13	23386 F	33
605 A	25, 29	21104 H	39	22571 B	13	23386 G	33
643-127	13	21104 V	39	22575	27	23386 H	33
643-263	13	21114	39	22580 D	19	23386 J	33
650-10	37	21114 A	39	22584	31	23425 V	33, 35
652-16	39	21114 D	39	22585 A	11	23454	35
660-74	11	21114 H	39	22585 B	19	23454 A	35
660-75	11	21114 L	39	22586 R	15	23454 B	35
660-136	13	21114 M	39	22587	23	23454 C	35
660-167	37	21114 S	39	22596	21	23454 D	35
660-169	19	21114 T	39				
660-202	15, 23						

NOTE: Only the basic part numbers are shown in the index. For various gauges, capacities, etc. available, refer to the listings on pages indicated.

NUMERICAL INDEX OF PARTS

<u>Part No.</u>	<u>Page No.</u>	<u>Part No.</u>	<u>Page No.</u>	<u>Part No.</u>	<u>Page No.</u>	<u>Part No.</u>	<u>Page No.</u>
23454 E.....	35	51254 C.....	15	51725 C.....	27	52944 U.....	13
23454 F.....	35	51254 D.....	13	51730 G.....	29	52958.....	19
23454 G.....	35	51254 K.....	15	51730 H.....	29	52994 AC.....	13
23454 H.....	35	51256 C.....	21	51730 J.....	29	53716.....	23
23454 J.....	35	51257 K.....	21	51741 C.....	17	53752.....	23
23454 L.....	35	51257 M.....	21	51744 A.....	17	53782 B.....	11
23454 M.....	35	51257 P.....	19	51745.....	17	53783 L.....	21
28577.....	33, 37	51257 AA.....	13	51757 B.....	19	53783 M.....	21
29066 R.....	15	51270 B.....	11	51758.....	11	53783 N.....	21
29105 AA.....	15	51280 J.....	25	51764.....	33	53783 S.....	21
29126 DE.....	23	51281 AF.....	27	51770.....	17, 25	53787.....	21
29192 C.....	17	51281 AG.....	27	51771.....	17, 25	53790 A.....	23
29192 D.....	17	51282 Y.....	11	51772.....	17	54158.....	15
29192 K.....	17	51282 Z.....	11	51773.....	17	54158 A.....	15
29348 S.....	15	51282 AC.....	11	51776 A.....	25	54244 L.....	17
29348 AF.....	15	51282 AE.....	11	51776 B.....	25	54249.....	23
29476 DV.....	19	51282 AH.....	11	51776 C.....	25	54249 B.....	25
29476 GG.....	25	51283 H.....	21	51780 B.....	25	54249 C.....	25
29476 HD.....	15	51290 T.....	13	51782 A.....	11	54249 D.....	25
29476 HE.....	15	51291 A.....	11	51794 B.....	13	54264 B.....	33
29480 KP.....	25	51292 A.....	21	51794 C.....	13	54264 C.....	33
33174 B.....	25	51292 C.....	21	51801 A.....	27	54274 F.....	25
35178 D.....	13	51292 D.....	21	51805.....	31	54274 G.....	25
35731 A.....	11	51292 F.....	21	51808.....	17	54274 H.....	25
39552 C.....	21	51292 G.....	21	51808 A.....	17	54274 J.....	25
39582 L.....	11	51294 K.....	13	51809.....	17	54274 K.....	25
39592 Z.....	35	51294 M.....	13	51813.....	17	54274 L.....	25
39592 AK.....	35	51294 P.....	13	51817 A.....	27	54274 N.....	25
41047.....	17	51294 R.....	13	51818.....	27	54274 P.....	25
41255 B.....	23	51294 U.....	13	51820.....	31	54274 R.....	25
41394 A.....	11	51294 Z.....	13	51824.....	31	54275 C.....	25
43137 E.....	25	51295 A.....	13	51825 B.....	27	54276 A.....	25
43245 N.....	25	51382 A.....	11	51825 C.....	27	54276 L.....	25
43266.....	21	51401 S.....	27	51825 CA.....	27	54276 W.....	25
51054.....	15, 19	51406.....	19	51830.....	31	54277 B.....	25
51134 C.....	19	51408.....	17	51830 A.....	31	54277 C.....	25
51134 J.....	19	51409.....	17	51830 B.....	31	54277 G.....	25
51134 P.....	19	51417 D.....	27	51830 C.....	31	54277 J.....	25
51134 R.....	19	51418.....	27	51830 D.....	31	54277 K.....	25
51144.....	17	51423 C.....	19	51833.....	27	54277 HA.....	25
51145 A.....	19	51425 E.....	27	51833 A.....	27	54278 B.....	25
51150.....	15	51430 D.....	29	51854 E.....	13	54278 S.....	25
51204.....	19	51430 F.....	29	51854 F.....	13	54278 T.....	25
51204 A.....	19	51434.....	19	51858.....	11	54278 U.....	25
51204 B.....	19	51454 A.....	11	51859 B.....	11	54278 V.....	25
51204 C.....	19	51454 B.....	15	51864.....	33	54278 W.....	25
51216 G.....	15	51459 A.....	19	51870.....	11	54278 X.....	25
51216 M.....	15	51464.....	33	51880.....	35	54278 Y.....	25
51216 N.....	15, 17	51475 A.....	25	51892.....	21	54278 AB.....	25
51216 P.....	15	51476 A.....	25	51899.....	37	54293 A.....	13
51222.....	19	51480 D.....	25	51959 B.....	19	55235 D.....	25
51225 W.....	19	51482 A.....	11	51959 D.....	19	55235 E.....	25
51235.....	19	51491 C.....	21	51959 K.....	19	55241 N.....	17
51235 A.....	19	51492.....	19	52336 A.....	15	55244 G.....	17
51235 C.....	19, 25	51493 D.....	13	52470.....	17	55641.....	17
51236 A.....	19	51493 E.....	13	52841 G.....	15	56315.....	15
51236 B.....	19	51493 AG.....	13	52841 J.....	15	56315 A.....	15
51236 D.....	19	51493 AH.....	13	52849 C.....	23	56334 L.....	19
51236 E.....	19	51493 AY.....	13	52854.....	23	56341 G.....	17
51236 F.....	19	51493 BA.....	13	52882 L.....	11	56350 A.....	15
51236 G.....	19	51493 BC.....	37	52882 M.....	11	56350 B.....	15
51240 E.....	17	51493 BD.....	13	52882 P.....	11	56350 D.....	15
51241 K.....	17	51493 BG.....	13	52882 U.....	11	56350 E.....	15
51242 L.....	15	51493 BH.....	13	52882 W.....	11	56350 F.....	15
51242 M.....	15	51493 BJ.....	13	52882 Y.....	11	56350 G.....	15
51242 P.....	15	51493 BK.....	13	52882 AA.....	11	56354 A.....	15
51242 R.....	13	51493 BP.....	15	52882 AC.....	11	56354 D.....	15
51242 S.....	13	51493 BQ.....	13	52882 AD.....	11	56356.....	21
51242 W.....	17	51513.....	17	52882 AE.....	11	56382 X.....	21
51242 Y.....	15	51701 V.....	27	52883 R.....	13	56382 AC.....	15
51242 Z.....	13	51704.....	19	52883 S.....	21	56390 E.....	19
51243 C.....	15	51708.....	17	52890 C.....	13	56392 E.....	35
51244.....	17	51709.....	17	52891 B.....	13, 15	56458.....	15
51244 B.....	17	51713.....	17	52894 AB.....	13	56458 A.....	15
51244 L.....	17	51718 A.....	27	52894 AK.....	13	56517 B.....	27
51244 N.....	17	51718 B.....	27	52894 AM.....	13	61394 V.....	11
51246.....	17	51720 F.....	29	52921 B.....	15	K72393.....	33
51250 D.....	15	51722.....	19	52936.....	13	75080 C.....	33
51250 F.....	15	51723 A.....	19	52944 T.....	13	80557.....	21

NOTE: Only the basic part numbers are shown in the index. For various gauges, capacities, etc. available, refer to the listings on pages indicated.

Helpful, authoritative information on the most efficient types of equipment for making virtually any machine sewed article is available from Union Special Sales Promotion Department. Among the many interesting, illustrated bulletins that are available without obligation are the following:

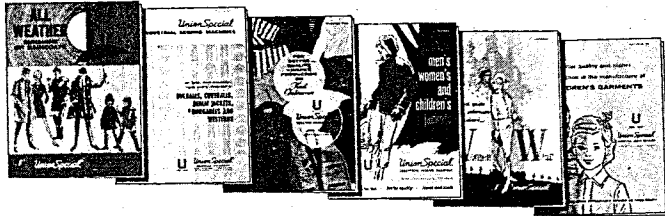

- No. 240, "Men's, Women's, Children's Footwear"
- No. 249, "Rainwear"
- No. 250, "Men's Dress Shirts"
- No. 251, "Service Shirts and Pants"
- No. 252, "Men's Shorts and Pajamas"
- No. 253, "Overalls, Coveralls, and Dungarees"
- No. 254, "Men's Knit Underwear"
- No. 256, "Knit Outerwear"
- No. 259, "Men's Sports Shirts"
- No. 260, "Work Gloves"
- No. 262, "Cotton, Burlap, Jute, and Multiwall Paper Bags"
- No. 263, "Men's Clothing"
- No. 264, "Men's Women's, Children's Jackets"
- No. 265, "Women's Wear"
- No. 266, "Women's Wear And High Fashion"
- No. 267, "Corsets, Girdles, Brassieres"
- No. 268, "Children's Wear"
- No. 269, "Mattresses, Slip Covers, Furniture Upholstery"
- No. 271, "Awnings, Canopies, Tents, Tarps"
- No. 273, "Curtains & Drapes"
- No. 610, "Klipp-it"
- No. 710, "MCS ForMation Unit"
- No. 730, "MCS Automatic Dual Underfront Shirt Hemmer"
- No. 740, "MCS Automatic Rib-Knit Cuff Machine"
- No. 750, "Fusing Presses"
- No. 1100, "Lewis Blindstitch, Chainstitch, Lockstitch, Machines"
- No. 1105, "Button Sewers—Ticket Tackers"
"Columbia Blindstitch, Saddle Stitch, and Tie Closing Machines"
- No. 1500, "Alteration Department Machines"



**UNION SPECIAL
CORPORATION**

**HERE ARE HELPFUL
BULLETINS and CATALOGS
TO HELP YOU SOLVE
SEWING PROBLEMS**

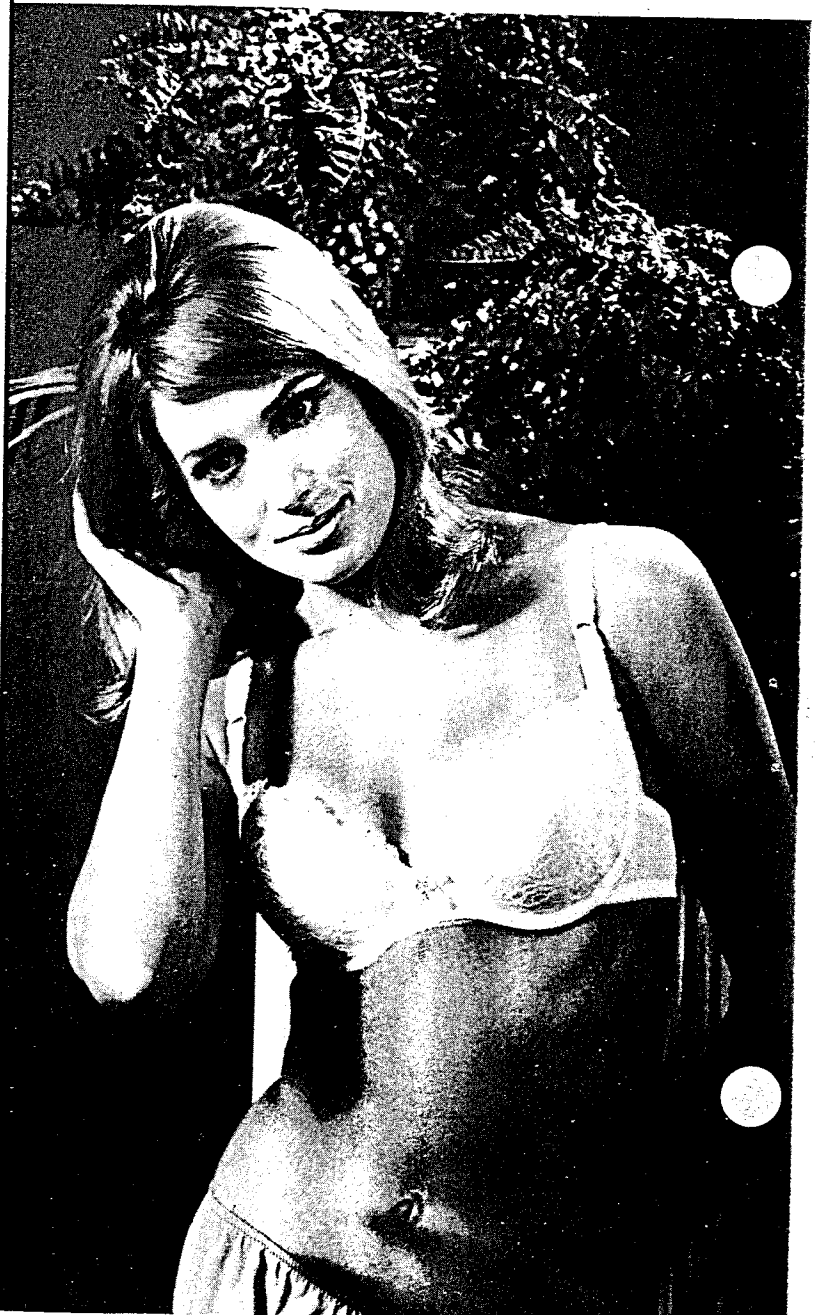

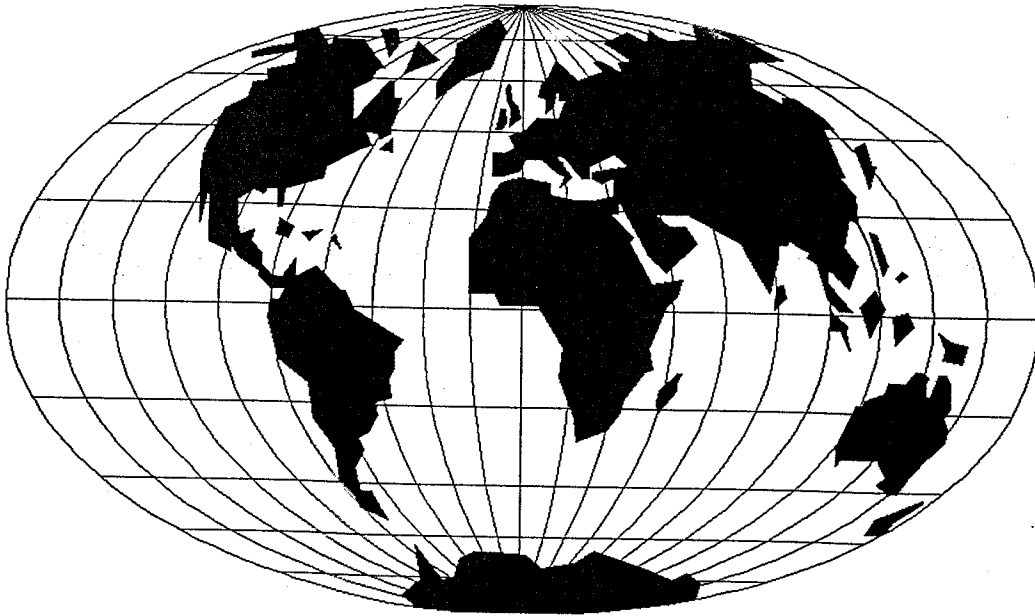

WORLDWIDE SALES AND SERVICE

Union Special Corporation maintains sales and service facilities throughout the world. These offices will aid you in the selection of the right sewing equipment for your particular operation. Union Special Corporation representatives and service technicians are factory trained and are able to serve your needs promptly and efficiently. Whatever your location, there is a qualified representative to serve you.

Brussels, Belgium
Charlotte, N.C.
Hong Kong, China
Huntley, IL
Leicester, England
Lille, France
Miami, FL
Milan, Italy
Möglingen, Germany
Montreal, Quebec
Osaka, Japan
Santa Fe Springs, CA
Suwanee, GA
Wayne, NJ

Other Representatives throughout
all parts of the world.



Union Special
INDUSTRIAL SEWING EQUIPMENT