

PFAFF

1242

1242

Teileliste

Parts list

Liste de pièces

Lista de piezas



Alle Informationen und Abbildungen waren zum Zeitpunkt der Druckgebung auf dem neuesten Stand.

Technische Änderungen vorbehalten!

Der Nachdruck, die Vervielfältigung sowie die Übersetzung – auch auszugsweise – aus PFAFF-Teilelisten ist nur mit unserer vorherigen Zustimmung und mit der Quellenangabe gestattet.

At the time of printing, all information and illustrations contained in this document were up to date.

Subject to alteration!

The reprinting, copying or translation of PFAFF parts lists whether in whole or in part, is only permitted with our previous permission and with written reference to the source.

Au moment de la remise à l'imprimeur, toutes les informations et figures se rapportant à cette machine correspondaient à l'état actuel des connaissances.

Sous réserve de modifications techniques!

Aucune reproduction, polycopie ou traduction – même par extraits – listes de pièces PFAFF ne peut être effectuée, à condition d'en indiquer l'origine, sans notre autorisation expresse.

Todas las informaciones e ilustraciones de este manual estaban al día en el momento de entregarse para su impresión.

¡ Salvo modificaciones técnicas!

La reimpresión, reproducción y traducción – aunque sólo sea parcial – de los manuales de instrucciones PFAFF sólo está permitida con nuestro permiso previo e indicando la fuente.

G.M. PFAFF AG
Postfach 3020
D-67653 Kaiserslautern

Redaktion/Illustration
Verlag Technische Dokumentation
Postfach 1106
D-77901 Lahr

| | | Seite Page Page Página |
|-------|--|---------------------------------|
| 10 | Wichtiger Hinweis Important note Avis important Observación importante | 0 - 1 |
| 11 | Vorwort Foreword Avant-propos Notas preliminares | 1 - 1 |
| 12 | Erläuterungen der Schlüsselzeichen Explanation of key markings Explication des symboles Explicaciones de los signos clave | 2 - 1 |
| 13 | Basismaschine Basic machine Machine de base Máquina básicas | |
| 13.01 | Gehäuseteile Housing sections Parties du corps Piezas del cárter | 3 - 1 |
| 13.02 | Kopfteile Needle head parts Pièces de tête Piezas de la cabeza | 3 - 2 |
| 13.03 | Armteile Arm parts Pièces de bras Piezas del brazo | 3 - 6 |
| 13.04 | Grundplattenteile Bedplate parts Pièces du plateau fondamental Piezas del cárter | 3 - 9 |
| 14 | Fadenabschneid-Einrichtung (-900/56) Thread trimmer (-900/56) Coupe-fil (-900/56) Cortahilos (-900/56) | 4 - 1 |

| | |
|----|--|
| 15 | Presserfuß-Automatik (-910/98) 5 - 1 Automatic presser foot lifter (-910/98) Relève-pied automatique (-910/98) Alzaprensatelas (-910/98) |
| 16 | Verriegelungs-Einrichtung (-911/97) 6 - 1 Backtacking mechanism (-911/97) Dispositif à points d'arrêt (-911/97) Rematador (-911/97) |
| 17 | Wartungseinheit (-925/03) 7 - 1 Air filter / lubricator (-925/03) Conditionneur d'air comprimé (-925/03) Grupo acondicionador del aire comprimido (-925/03) |
| 18 | Garnrollenständer 8 - 1 Reel stands Porte-bobines Portacarretes |
| 19 | Einstellehren 9 - 1 Adjustment gauges Calibres Calibres de ajuste |
| 10 | Teile zur Tischplatte 9 - 1 Parts for table top Pièces du plateau Piezas para el tablero |
| 11 | Fadenöler 11 - 1 Thread lubricator Graisseur de fil Lubricador del hilo |
| 12 | Keilriemen 11 - 1 V-belt Courroie trapézoïdale Correa trapezoidal |
| 13 | Schmiermittel-Übersicht 13 - 1 Overview of lubricants Tableau de lubrifiants Tabla de lubricantes |
| 14 | Index (Teilenummern / Seitenzahlen) 14 - 1 Index (part numbers / page numbers) Index (numéros de pièces, de pages) Index (números de pieza / números de página) |

| | | |
|-------|--|--------|
| 15 | Unterklassen-Ausstattung Subclass parts Composition des sous-classes Composición de las subclases | |
| 15.01 | Unterklassen-Übersicht (PFAFF 242) Table of subclasses (PFAFF 242) Table de sous-classes (PFAFF 242) Table de subclases (PFAFF 242) | 15 - 1 |
| 15.02 | Nähwerkzeuge (PFAFF 242) Gauge parts (PFAFF 242) Organes de couture (PFAFF 242) Organos de costura (PFAFF 242) | 15 - 2 |
| 15.03 | Unterklassen-Übersicht (PFAFF 1242) Table of subclasses (PFAFF 1242) Table de sous-classes (PFAFF 1242) Table de subclases (PFAFF 1242) | 15 - 5 |
| 15.04 | Nähwerkzeuge (PFAFF 1242) Gauge parts (PFAFF 1242) Organes de couture (PFAFF 1242) Organos de costura (PFAFF 1242) | 15 - 6 |

Achtung!



Wir machen ausdrücklich darauf aufmerksam, daß Ersatz- und Zubehörteile, die nicht von uns geliefert werden, auch nicht von uns geprüft und freigegeben sind. Der Einbau und / oder die Verwendung solcher Produkte kann daher u. Umständen konstruktiv vorgegebene Eigenschaften Ihrer Maschine negativ verändern. Für Schäden, die durch die Verwendung von Nicht-Originalteilen entstehen, übernehmen wir keine Haftung!

Caution!



We warn you expressively that spare parts and accessories that are not supplied by us are not tested and released by us. Fitting or using these products may therefore have negative influences on features that depend on the machine design. We are not liable for any damage caused by the use of non-Pfaff parts!

Attention!



Nous attirons expressément votre attention sur le fait que les pièces de rechange et accessoires qui n'ont pas été livrés par nous n'ont pas non plus été contrôlés et agréés par nous. C'est pourquoi le montage et/ou l'utilisation de telles pièces peut éventuellement entraîner l'altération des caractéristiques de construction de votre machine. Par conséquent, nous n'assumons aucune responsabilité pour les dommages causés par l'emploi de pièces qui ne sont pas d'origine!

¡Atención!



Se hace observar que en el caso de piezas de recambio y accesorios que no hayan sido suministrados por nosotros, quiere decir que non han sido sometidas por nuestra parte a un control y que no se les ha dado el visto bueno. Por esta razón, el montaje y/o empleo de tales productos puede repercutir negativamente en las características previstas en su máquina. ¡Para los daños que eventualmente pudiesen presentarse al utilizar piezas no originales, no asumimos ninguna garantía!

- Alle Teile sind so abgebildet, wie sie in der Maschine funktionsmäßig zusammengehören.
- Gestrichelt dargestellte Teile zeigen angrenzende Teile aus anderen Funktionsgruppen.
- Im oberen Teil der Bildseiten befindet sich eine Gesamtansicht der Maschine .
Der Einbauort der dargestellten Teile wird durch eine gerasterte Fläche gekennzeichnet.
- Einrahmungen auf den Bildseiten zeigen, aus welchen Einzelteilen sich die Gruppenteile zusammensetzen.
- Die auf den Bildseiten verwendeten Schlüsselzeichen (; 2 ; 3 usw.) sind im Kapitel "Erläuterungen der Schlüsselzeichen" aufgelistet.

- All parts are illustrated in function groups with the parts which they function together with in the machine.
- Parts illustrated with broken lines are parts from other function groups which border on the illustrated function group.
- The above section of the page of illustrations contains a total view of the machine. The place for the installation of the parts pictured here is marked by the grid.
- The framed-in sections on the illustration pages show the individual parts comprising a group.
- The key markings used on the illustrated pages (; 2 ; 3 etc.) are listed in the chapter "Explanation of key markings".

- Toutes les pièces sont représentées en fonction de leur groupement fonctionnel dans la machine.
- Les pièces hâchurées indiquent les pièces limitrophes de groupes de fonctions différents.
- La partie supérieure des pages de figures comprend une présentation globale de la machine. L'emplacement des pièces représentées est signalé par quadrillages.
- Les parties encadrées sur les pages à illustrations représentent les pièces individuelles formant groupe.
- Vous trouverez au chapitre "Explication des symboles" une liste des symboles utilisés sur les pages de figures (; 2 ; 3 etc.)

- Todas las piezas están ilustradas tal como aparecen en la máquina para su funcionamiento.
- Las piezas representadas con rayitas muestran piezas colindantes de otros grupos de funciones.
- En la parte superior de las páginas ilustradas se puede ver una vista en conjunto de la máquina. El lugar de montaje de la pieza representada va caracterizada mediante una superficie reticulada.
- Los recuadros en las páginas ilustradas indican las piezas individuales de que se componen los grupos.
- Los signos clave (; 2 ; 3 etc.) empleados en las páginas con ilustraciones van listados en el capítulo "Explicaciones de los signos clave".

- Unterklassenabhängig, Teilenummer siehe Unterklassen-Ausstattung.
Subclass-dependent, for part number see subclass parts listing.
Fonction de la sous-classe; pour le numéro de la pièce, voir "Equipement de sous-classes".
Dependientes de la subclase, para el número de pieza véase "Dotación de subclases".
- B Ausführung B
Model B
Version B
Tipo B
- C Ausführung C
Model C
Version C
Tipo C
- 3 Geklebt
Part cemented
Pièce collée
Pieza pegada
- 4 Ausführungsart bei Bestellung angeben.
Model to be stated on order.
Préciser le modèle à la commande.
Indíquese el tipo en los pedidos.
- 6 Nadeldicke und Spitzenform bei Bestellung angeben.
Needle size and style of point to be stated on order.
Préciser la grosseur de l'aiguille et la forme de la pointe à la commande.
Grosor de aguja y forma de la punta, indíquese en los pedidos.
- 10 Nadelabstand
Needle gauge
Ecartement des aiguilles
Distancia entre agujas
- 10/2 Nadelabstand bei Bestellung angeben.
Needle gauge to be stated on order.
Ecartement des aiguilles; à préciser à la commande.
Indíquese en los pedidos la distancia entre agujas.
- 27/2 Eingeklammerte Zahl = Dicke in mm.
Number in brackets = thickness in mm.
Chiffre entre parenthèses = épaisseur en mm.
Cifra entre paréntesis = espesor en mm.

- 27/5 Eingeklammerte Zahl = Länge in mm.
 Number in brackets = length in mm.
 Chiffre entre parenthèses = longueur en mm.
 Cifra entre paréntesis = largura en mm.
- 28 Sonderausführung
 Special version
 Version spéciale
 Tipo especial
- 28/6 Sonderausführung, nur in Verbindung mit Distanzscheibe Nr. 91-140 414-05 oder
 Nr. 91-140 415-05 (siehe Seite 3 - 9).
 Special version, only in conjunction with spacing washer No. 91-140 414-05 or
 No. 91-140 415-05 (see page 3 - 9).
 Version spéciale, uniquement en liaison avec la rondelle intercalaire n° 91-140 414-05 ou
 n° 91-140 415-05 (voir page 3 - 9).
- 28/7 Tipo especial, sólo en combinación con la arandela distanciadora N° 91-140 414-05 ó
 N° 91-140 415-05 (véase página 3 - 9).
- Sonderausführung, Greiferbügel ohne Gegenspitze.
 Special version of sewing hook with hook gib without heel.
 Version spéciale de crochet, avec archet sans pointe.
 Tipo especial garfio con arco del garfio sin punta.
- 32 Beim Einbau dieses Teiles wird für die Paßgenauigkeit zum Anschlußteil keine Garantie
 übernommen; zweckmäßig vollständiges Aggregat bestellen.
 No guarantee is assumed that this part will fit the mating part; it is best to order a complete
 assembly.
 Aucune garantie ne pourra être assurée quant à la précision d'ajustage de cette pièce avec
 la pièce correspondante; il est indiqué de commander un mécanisme complet.
- 40/1 Al montar esta pieza no se asume garantía alguna en cuanto a la tolerancia y precisión de
 ajuste
 respecto a la pieza correspondiente; por esta razón, se recomienda pedir el grupo completo.
- Füllen mit 28-011-201-44; Bestellnummer siehe Seite 13 - 1.
 Top up with 28-011-201-44; for part number see page 13 - 1.
 Remplir de 28-011-201-44; n° de commande, voir page 13 - 1.
 Rellene con 28-011-201-44; para el número de pedido véase la página 13 - 1.
- 40/3 Fetten mit 28-011-202-47; Bestellnummer siehe Seite 13 - 1.
 Grease with 28-011-202-47; for part number see page 13 - 1.
 Graisser avec de la graisse 28-011-202-47; n° de commande, voir page 13 - 1.
 Engrase con grasa 28-011-202-47; para el número de pedido véase la página 13 - 1.
- 40/4 Fetten mit 28-011-202-43; Bestellnummer siehe Seite 13 - 1.
 Grease with 28-011-202-43; for part number see page 13 - 1.
 Graisser avec de la graisse 28-011-202-43; n° de commande, voir page 13 - 1.
 Engrase con grasa 28-011-202-43; para el número de pedido véase la página 13 - 1.

- 40/6 Füllen mit 28-011-202-17; Bestellnummer siehe Seite 13 - 1.
Top up with 28-011-202-17; for part number see page 13 - 1.
Remplir de 28-011-202-17; n° de commande, voir page 13 - 1.
Rellene con 28-011-202-17; para el número de pedido véase la página 13 - 1.
- 40/7 Tränken mit 28-011-202-17; Bestellnummer siehe Seite 13 - 1.
Grease with 28-011-202-17; for part number see page 13 - 1.
Graisser avec de la graisse 28-011-202-17; n° de commande, voir page 13 - 1.
Engrase con grasa 28-011-202-17; para el número de pedido véase la página 13 - 1.
- 40/13 Fetten mit 28-011-202-05; Bestellnummer siehe Seite 13 - 1.
Grease with 28-011-202-05; for part number see page 13 - 1.
Graisser avec de la graisse 28-011-202-05; n° de commande, voir page 13 - 1.
Engrase con grasa 28-011-202-05; para el número de pedido véase la página 13 - 1.
- 60 Wahlweise
Optional
Au choix
Opcional
- 90/47 Nr. 91-141 572-12 mitbestellen.
Include No. 91-141 572-12 in your order.
Comprendre la pièce n° 91-141 572-12 dans votre commande.
Pidase juntamente el N° 91-141 572-12.
- 96 Länge angeben.
State length.
Préciser longueur.
Indíquese la largura.

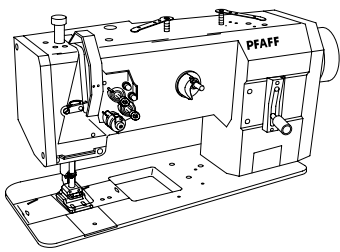

Gehäuseteile
Housing sections
Parties du corps
Piezas del cárter

PFAFF 1242
PFAFF 1242

3.01

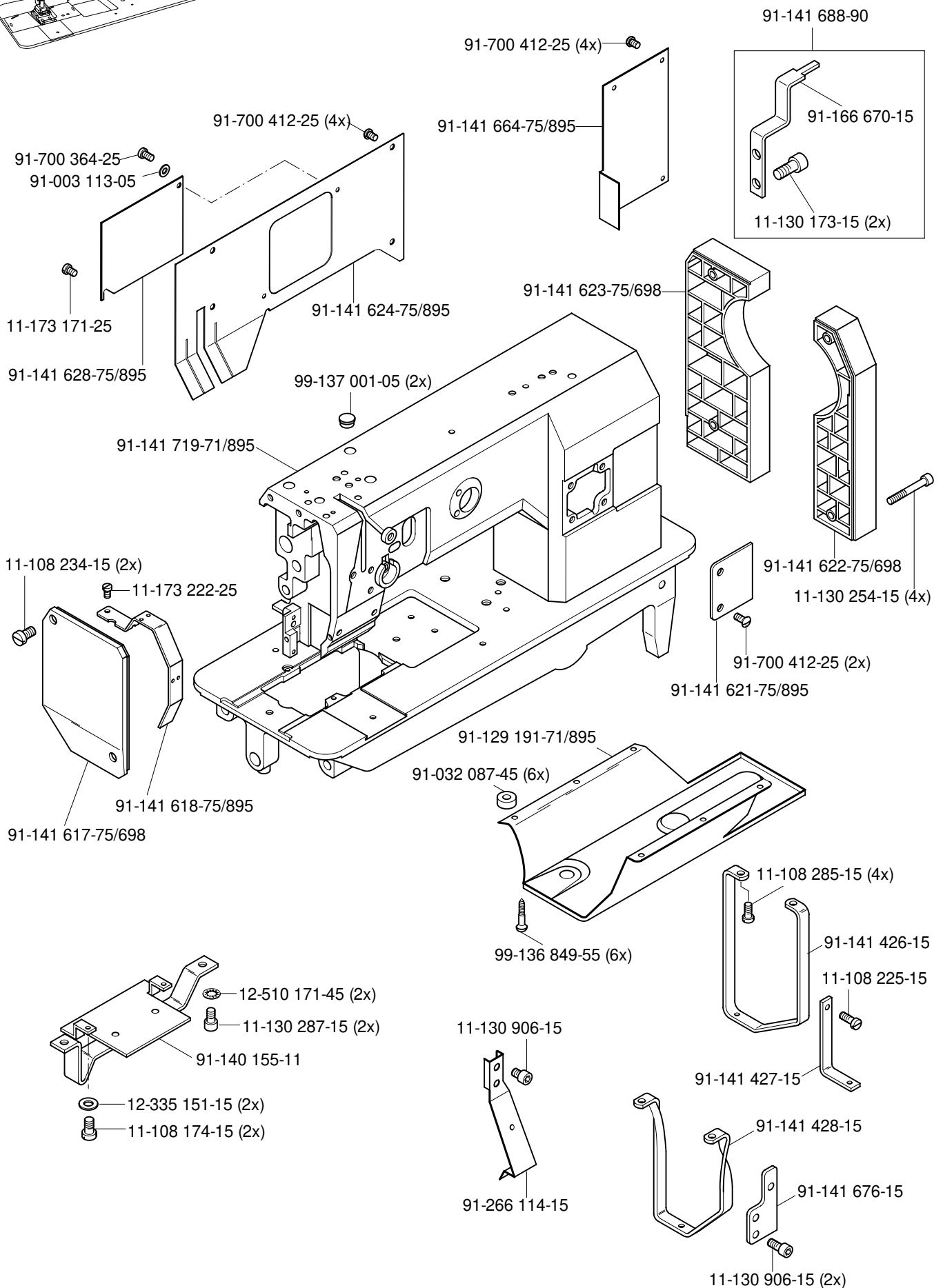

3.02

Kopfteile
Needle head parts
Pièces de tête
Piezas de la cabeza

PFAFF 1242
PFAFF 1242

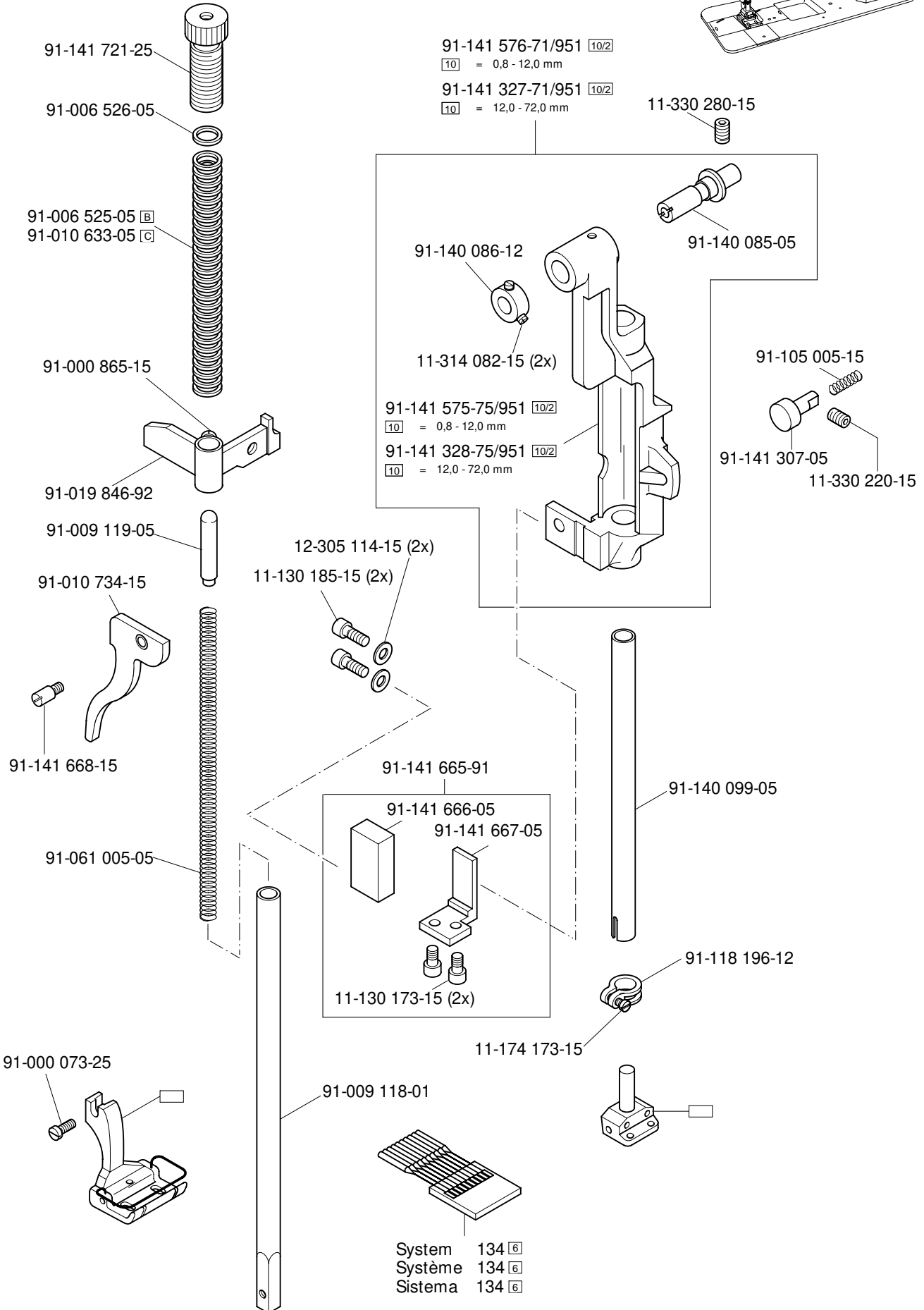
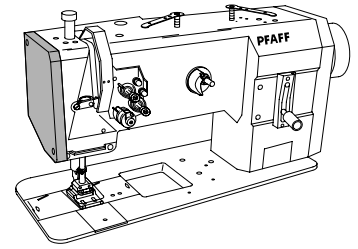

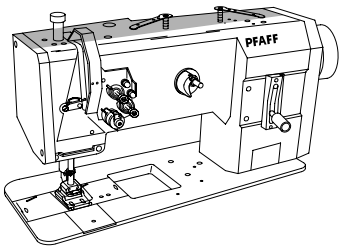

Kopfteile

Needle head parts

Pièces de tête

Piezas de la cabeza

PFAFF 1242

PFAFF 1242

3.02

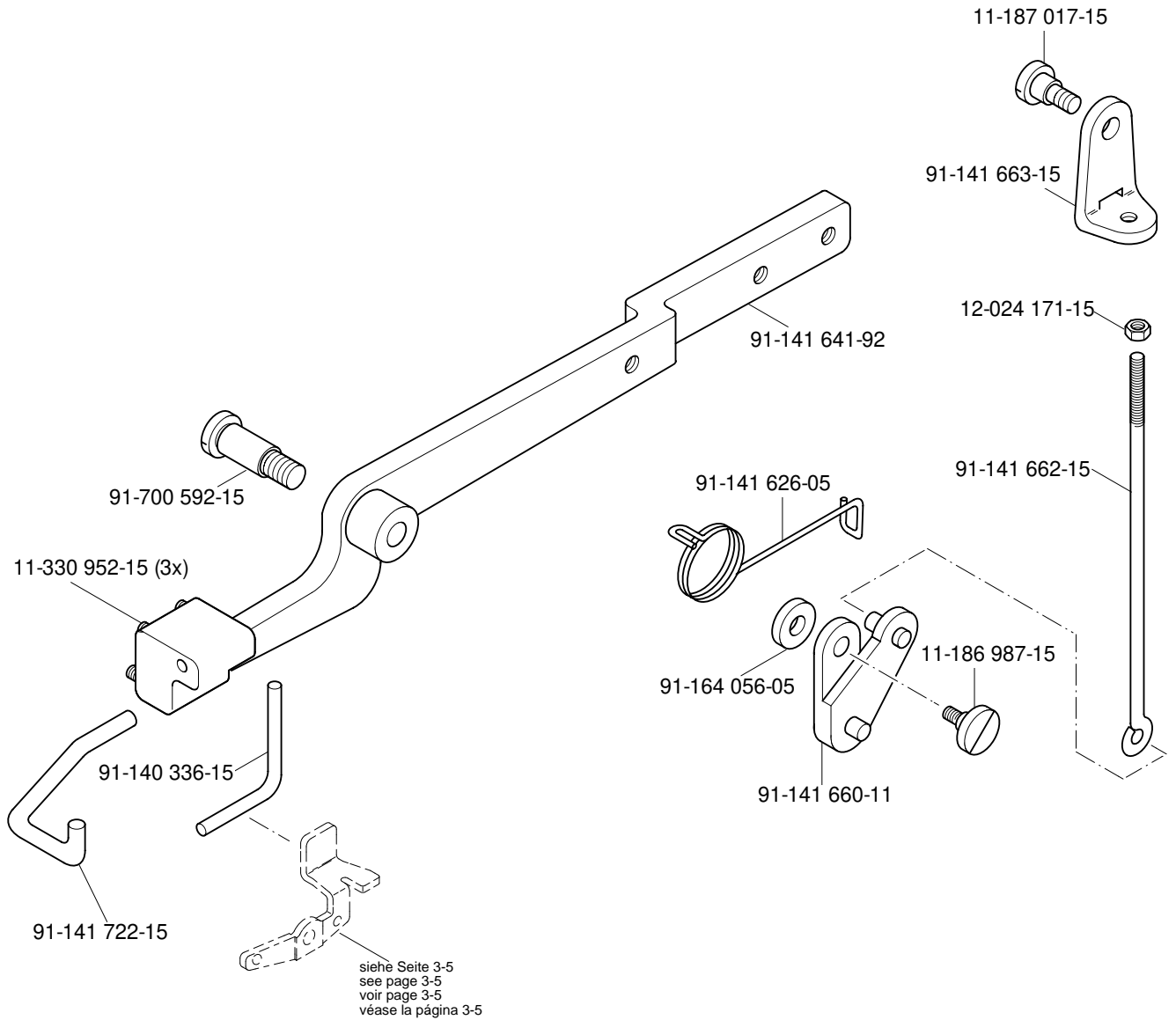

3.02

Kopfteile
Needle head parts
Pièces de tête
Piezas de la cabeza

PFAFF 1242
PFAFF 1242

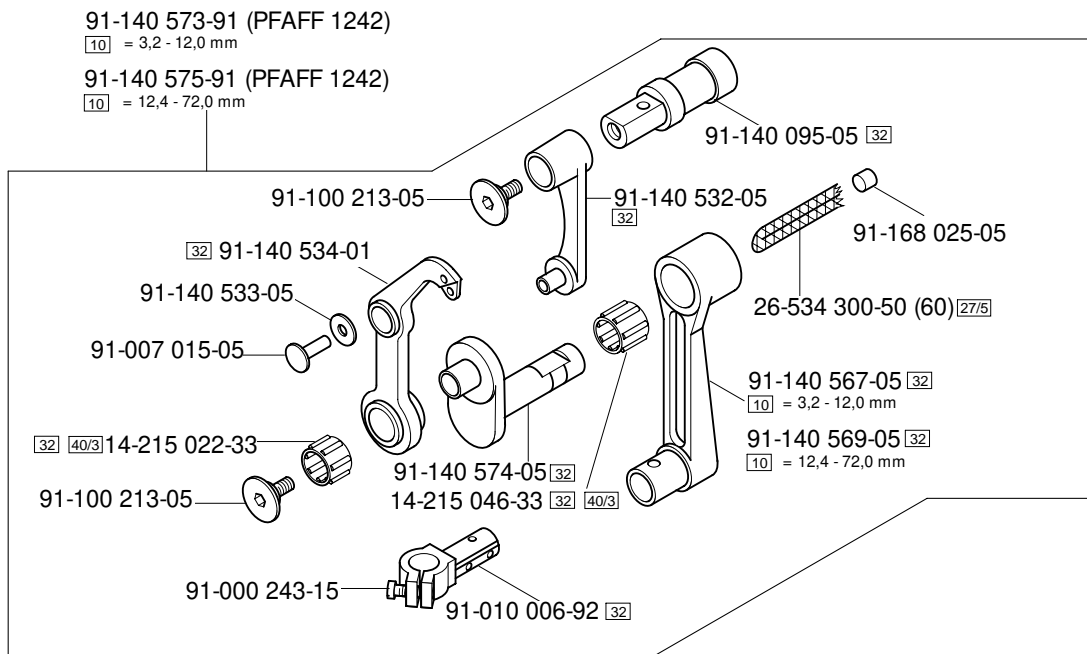
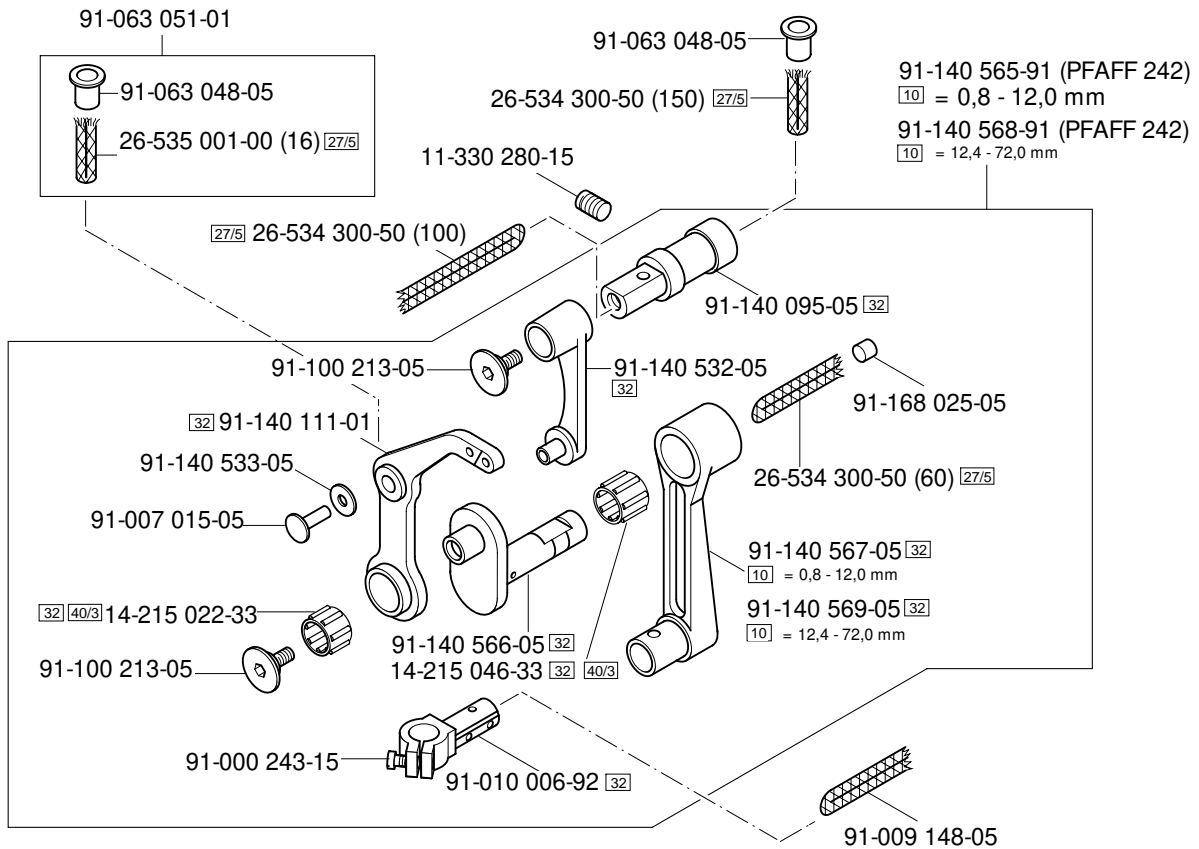
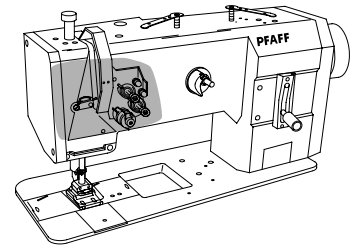

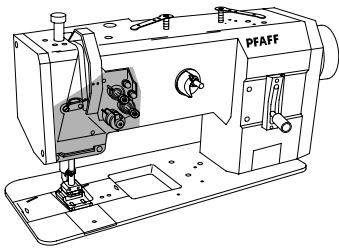

Kopfteile

Needle head parts

Pièces de tête

Piezas de la cabeza

PFAFF 1242

PFAFF 1242

3.02

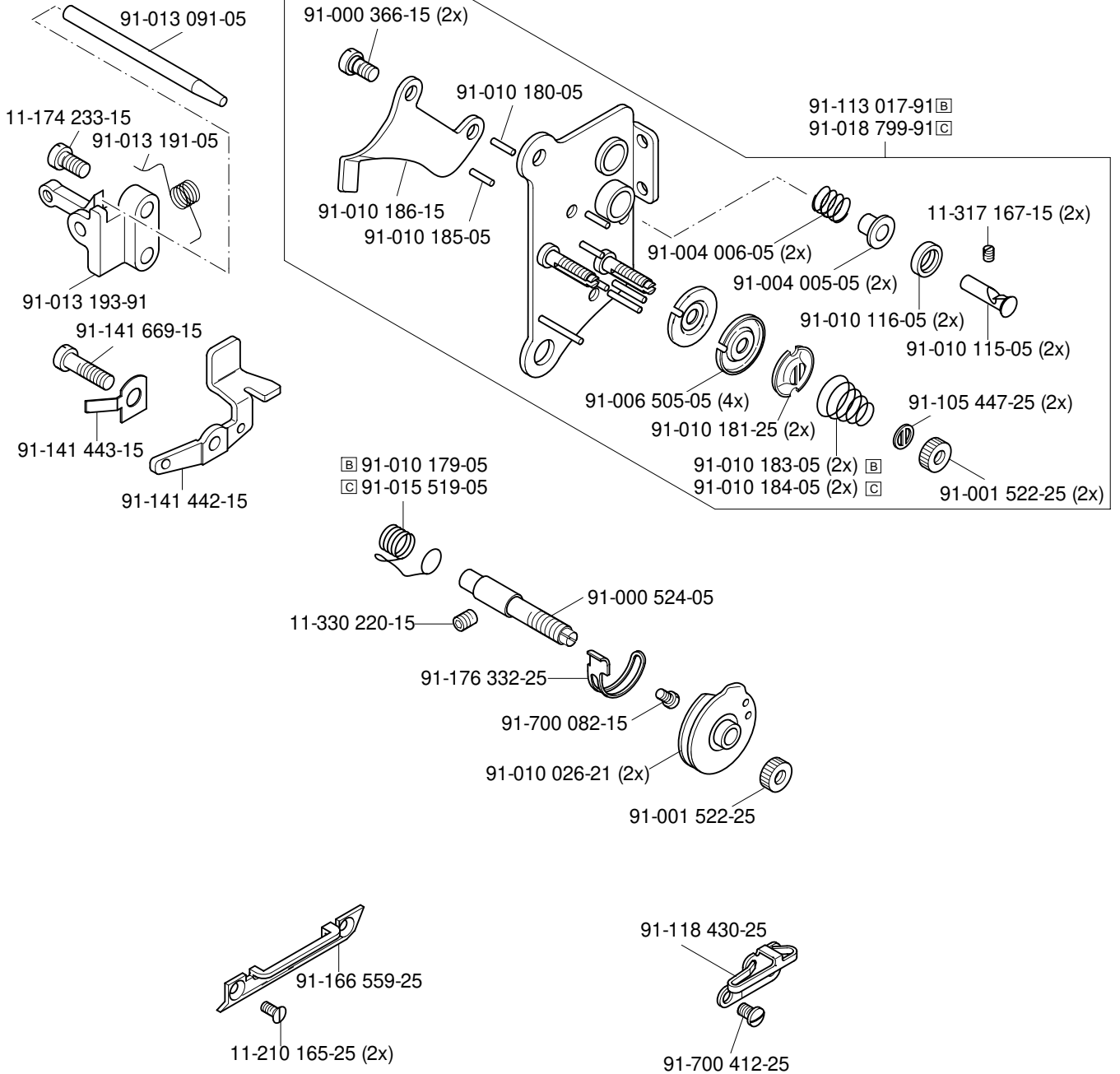

3.03

Armteile
 Arm parts
 Pièces de bras
 Piezas del brazo

PFAFF 1242
 PFAFF 1242

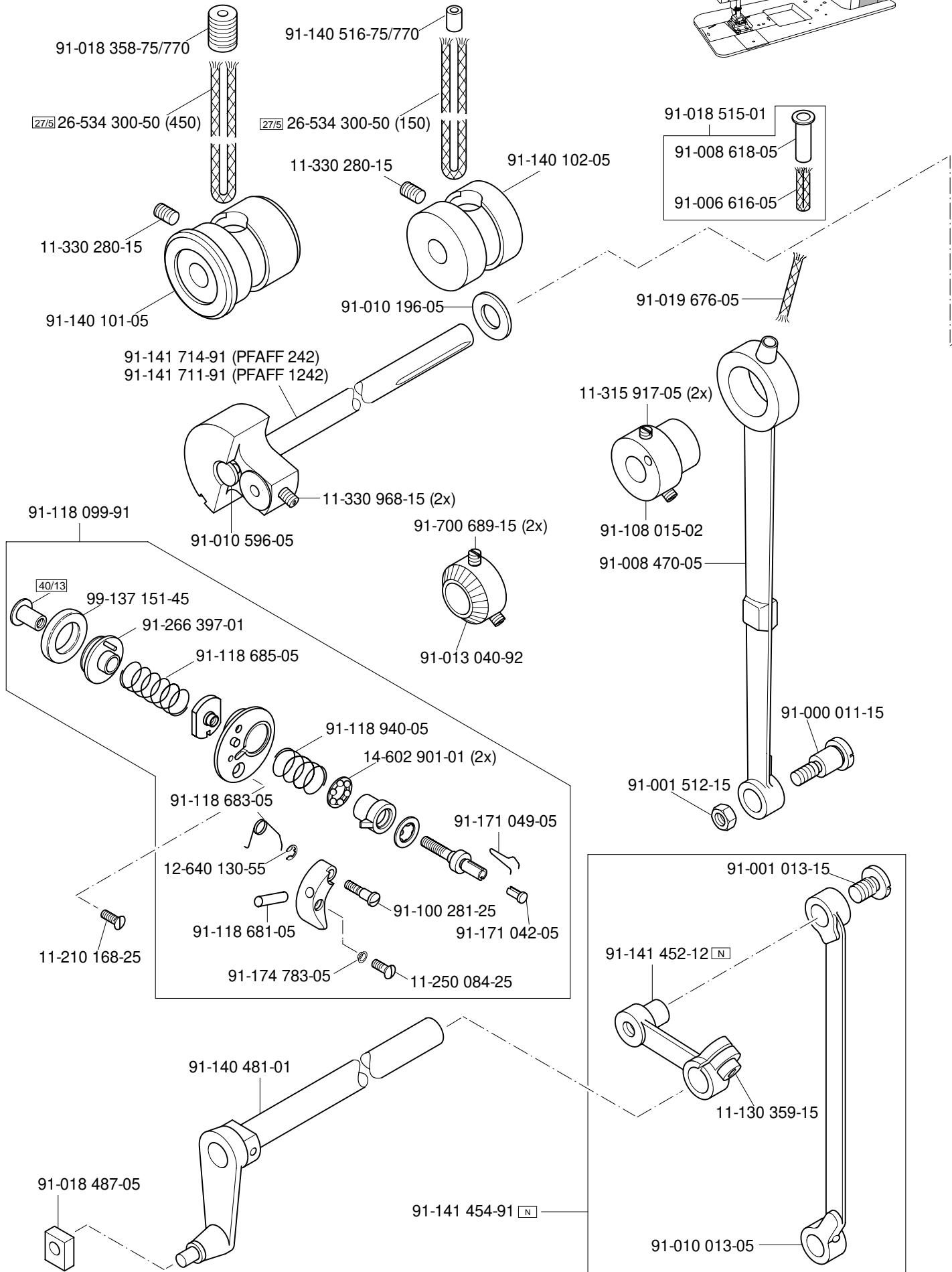
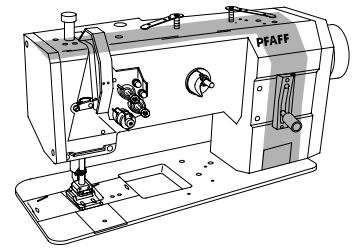

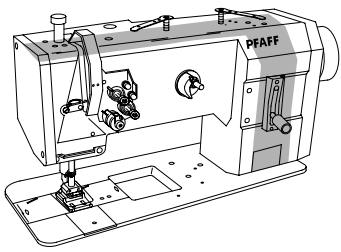

Armteile
 Arm parts
 Pièces de bras PFAFF 1242
 Piezas del brazo PFAFF 1242

3.03

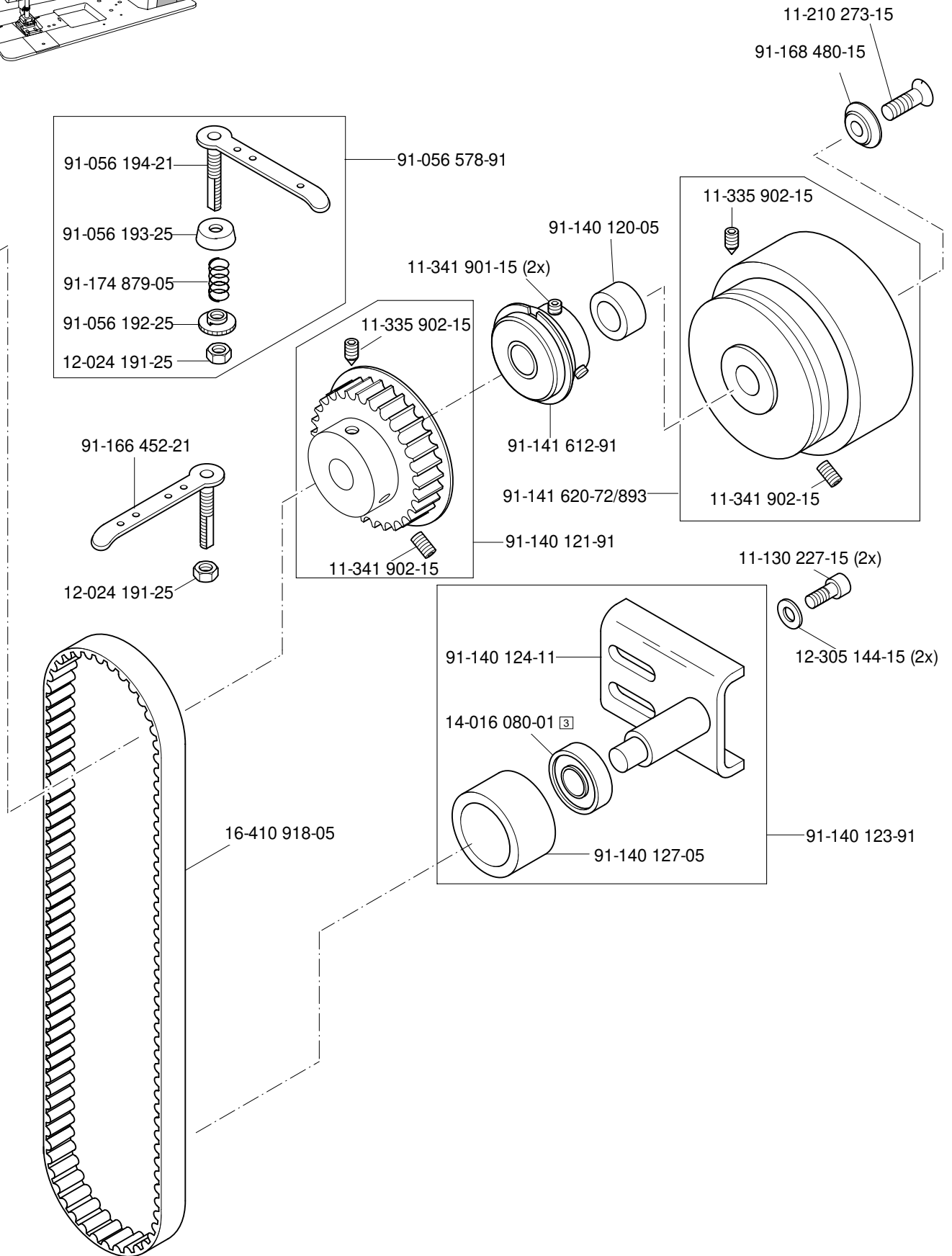

3.03

Armteile
 Arm parts
 Pièces de bras
 Piezas del brazo

PFAFF 1242
 PFAFF 1242

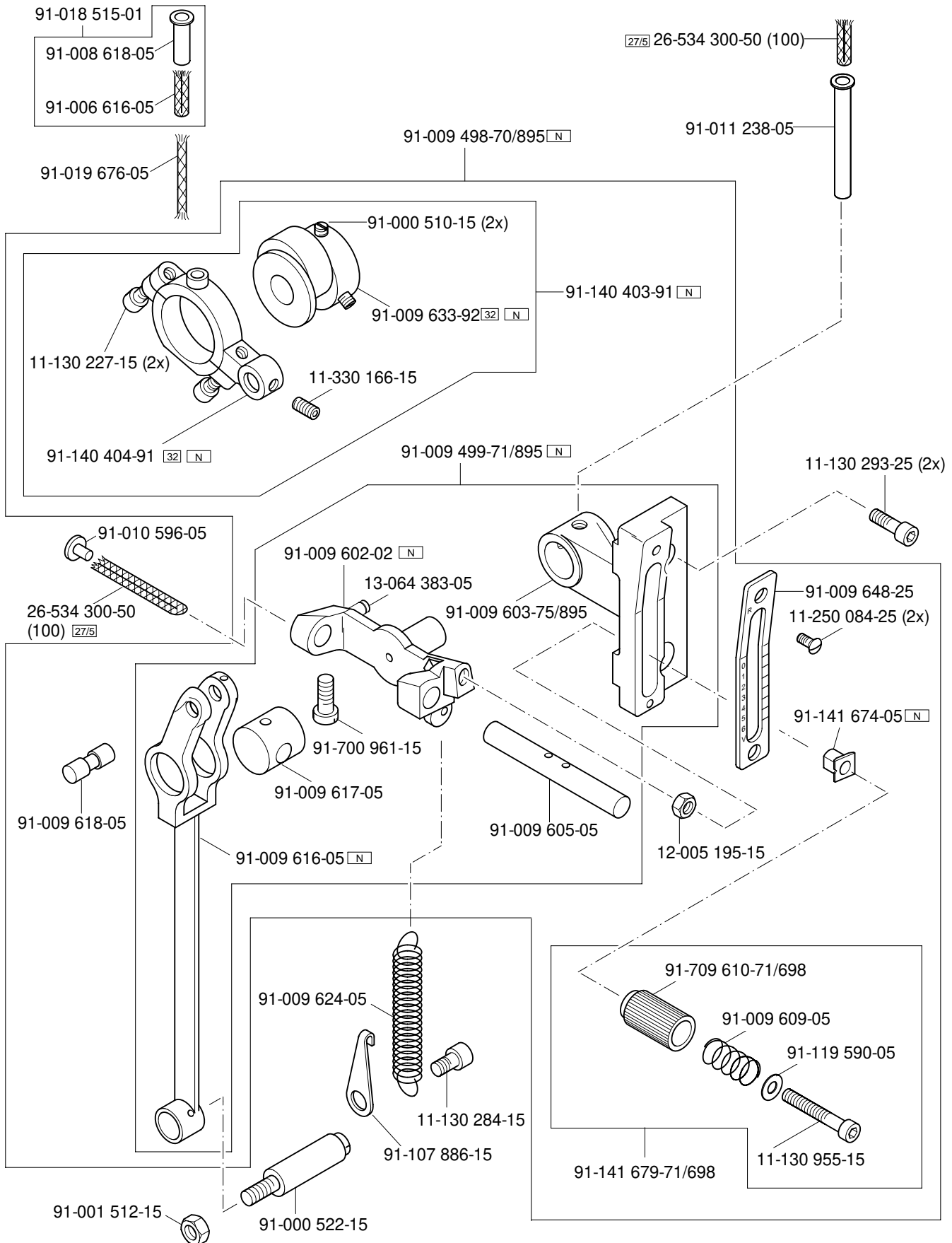
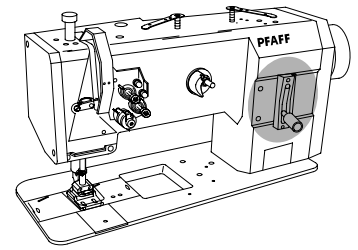

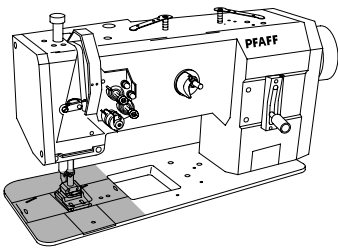

Grundplattenteile

Bedplate parts

Pièces du plateau fondamental

Piezas del cárter

PFAFF 1242

PFAFF 1242

3.04

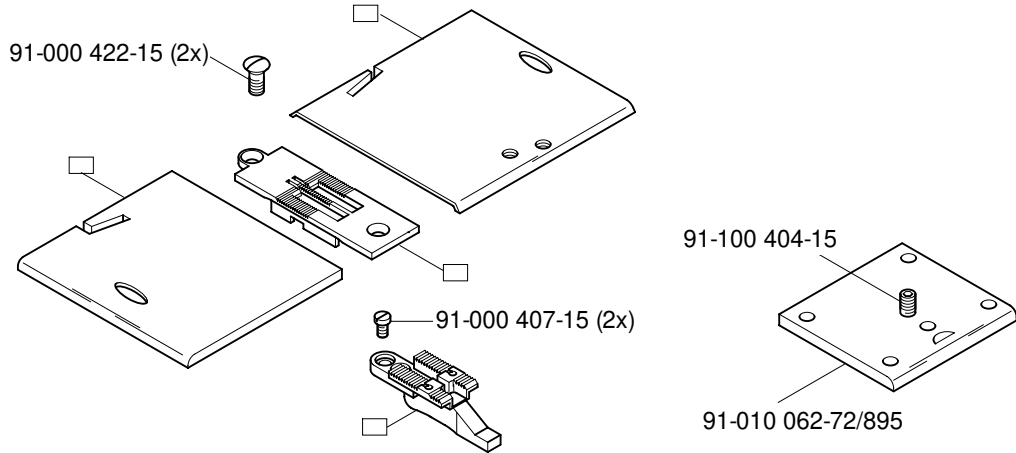

- [B] 91-140 454-91 (PFAFF 242)
- [28/7] [B] 91-140 543-91 (PFAFF 242)
- [B] 91-140 538-91 (PFAFF 1242)
- [C] 91-140 539-91 (PFAFF 1242)

für 900/.. siehe Seite 4-2
for 900/.. see page 4-2
pour 900/.. voir page 4-2
para 900/.. véase la página 4-2

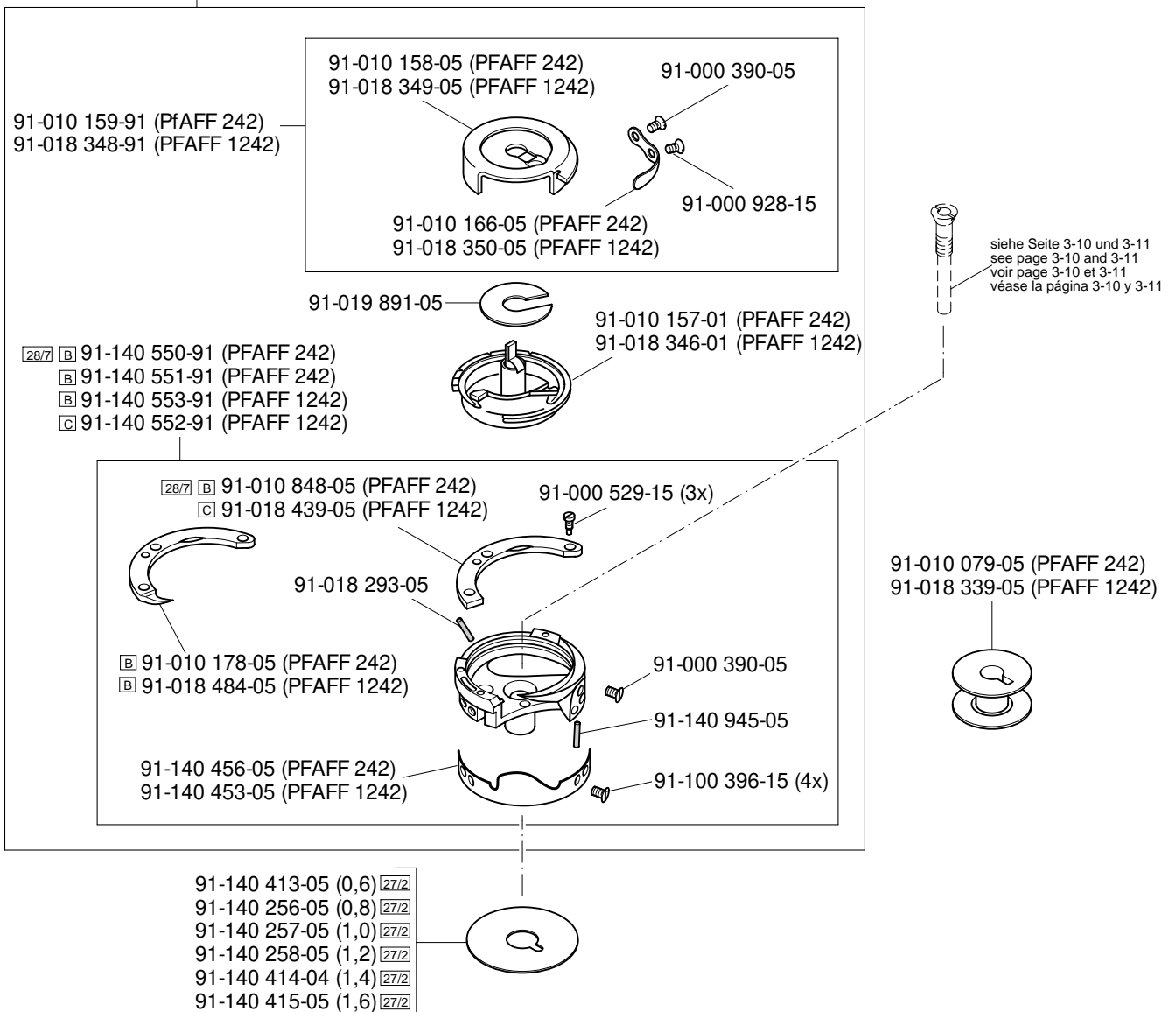

3.04

Grundplattenteile

Bedplate parts

Pièces du plateau fondamental

Piezas del cárter

PFAFF 1242

PFAFF 1242

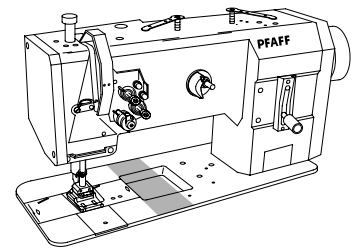

91-141 565-71/951 (PFAFF 242)
91-141 567-71/951 (PFAFF 1242)

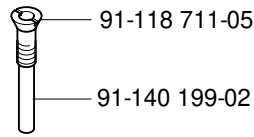

(PFAFF 1242) 91-140 253-05
(PFAFF 1242) 91-140 418-05 28/6



(PFAFF 242) 91-140 251-05
(PFAFF 242) 91-140 416-05 28/6



91-141 522-01 (PFAFF 242)
91-141 525-01 (PFAFF 1242)

91-141 549-71/951 (PFAFF 242)
91-141 551-71/951 (PFAFF 1242)

91-141 520-75/951

11-108 174-15

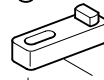
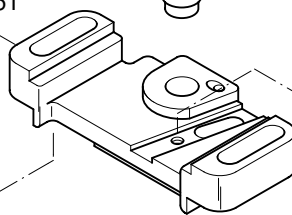

91-141 563-01

91-700 785-15 (2x)

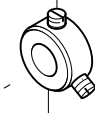

91-168 319-12

91-140 241-15



12-341 150-15 (2x)

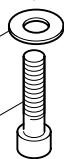

11-130 305-15 (2x)

91-700 785-15 (2x)



91-140 516-75/770

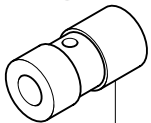

91-168 319-12

91-140 201-05 3

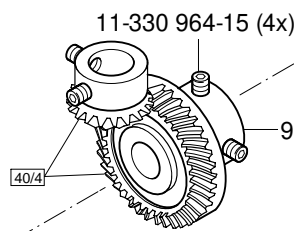

91-141 547-05

91-141 536-90

91-140 242-05

91-141 541-05

91-141 542-05

91-141 535-05

13-050 013-15

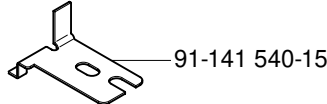

91-141 540-15

11-108 171-15

91-141 546-05

91-141 545-05

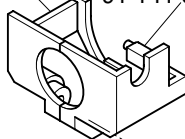

11-721 482-15

 siehe Kapitel 2 Erläuterung der Schlüsselzeichen
see chapter 2 Explanation of key markings
voir le chap. 2 Explication des symboles
véase el Cap. 2 Explicaciones de los signos clave

PFAFF

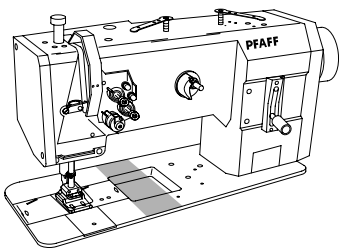

Grundplattenteile

Bedplate parts

Pièces du plateau fondamental

Piezas del cárter

PFAFF 1242

PFAFF 1242

3.04

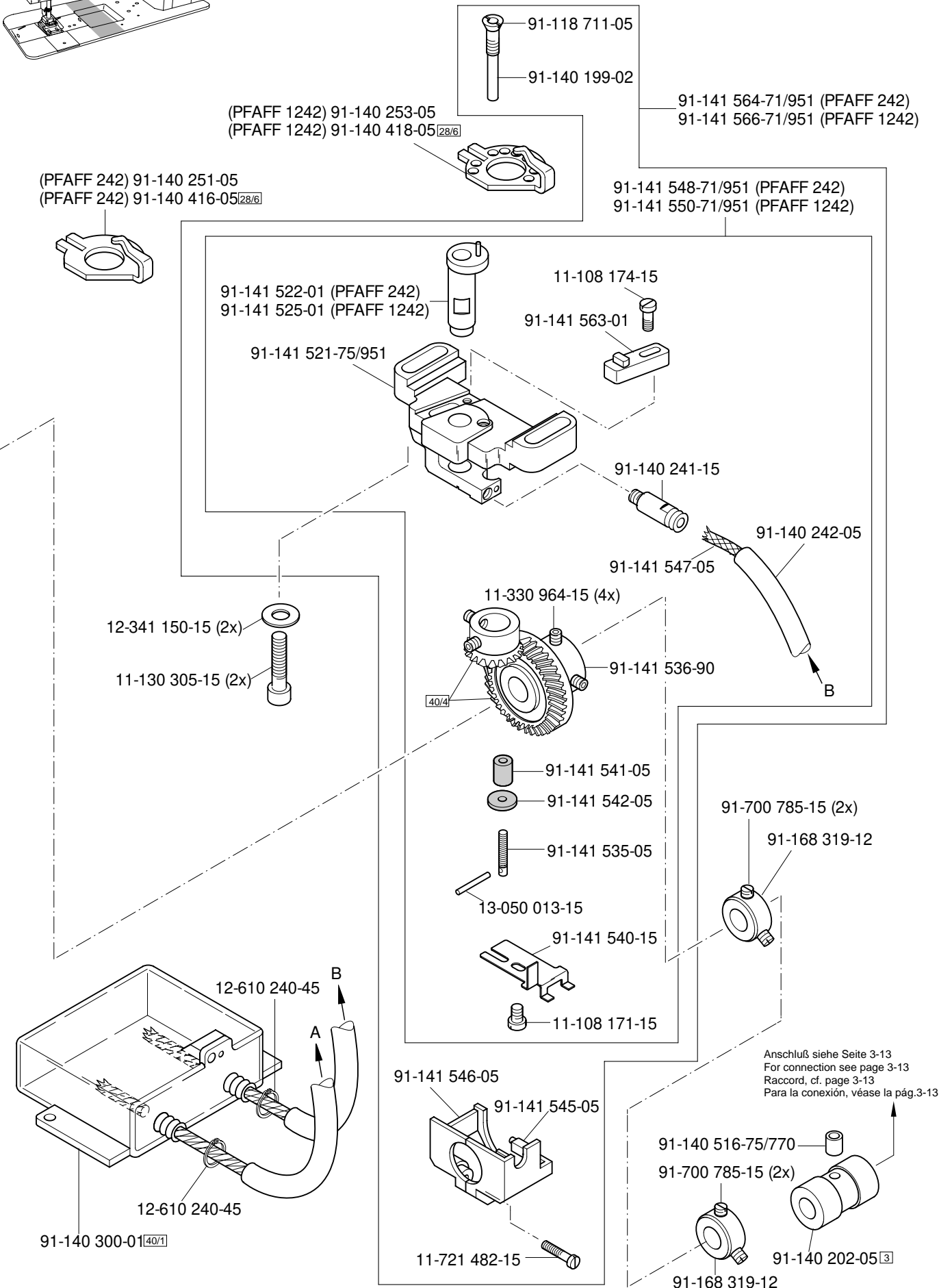

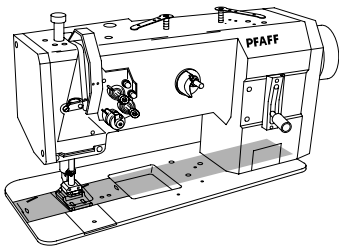

Grundplattenteile

Bedplate parts

Pièces du plateau fondamental

Piezas del cárter

PFAFF 1242

PFAFF 1242

3.04

91-141 087-05 (PFAFF 1242)

siehe Seite 3-11
see page 3-11
voir page 3-11
véase la página 3-11

91-140 560-90 (PFAFF 1242)

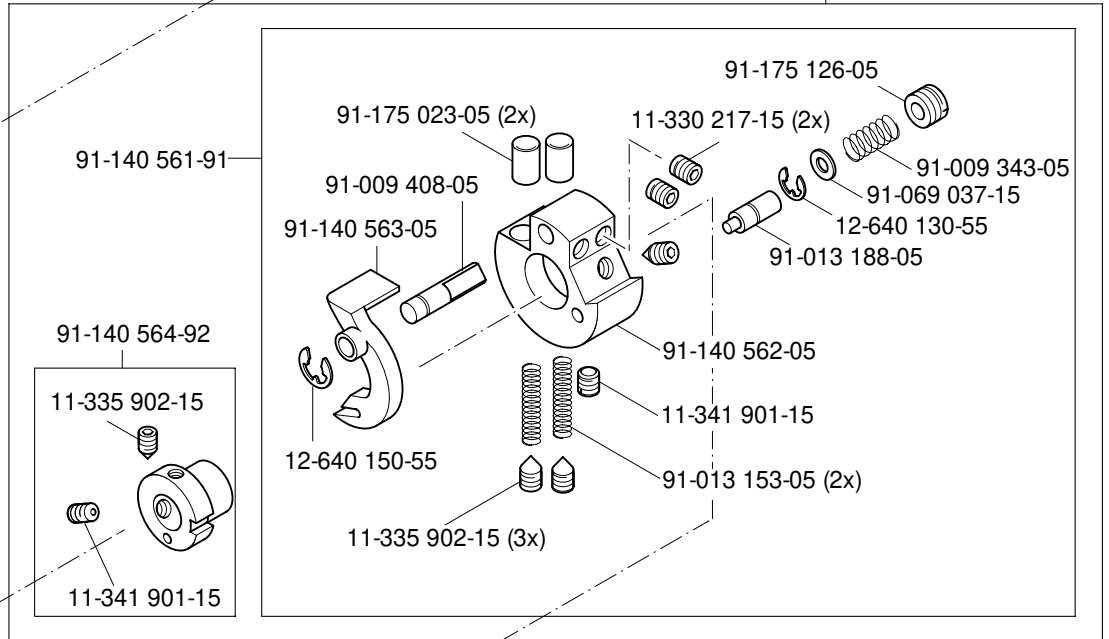

91-140 148-05 (PFAFF 1242)

91-140 122-91

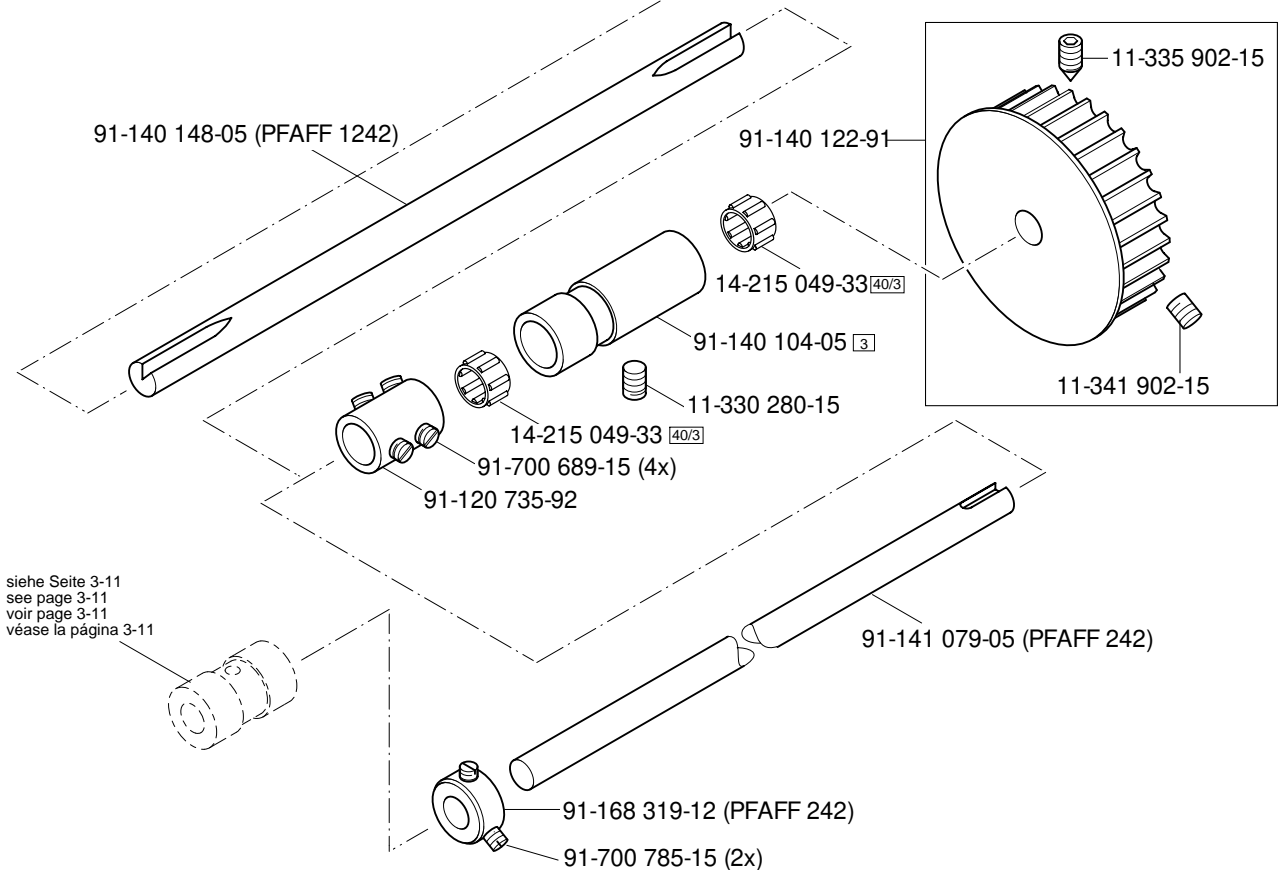

siehe Seite 3-11
see page 3-11
voir page 3-11
véase la página 3-11

3.04

Grundplattenteile
 Bedplate parts
 Pièces du plateau fondamental
 Piezas del cárter

PFAFF 1242
 PFAFF 1242

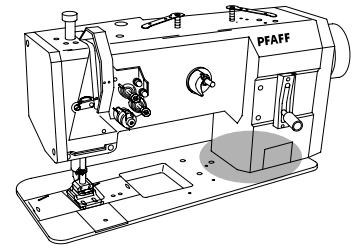

siehe Seite 3-3
 see page 3-3
 voir page 3-3
 véase la página 3-3

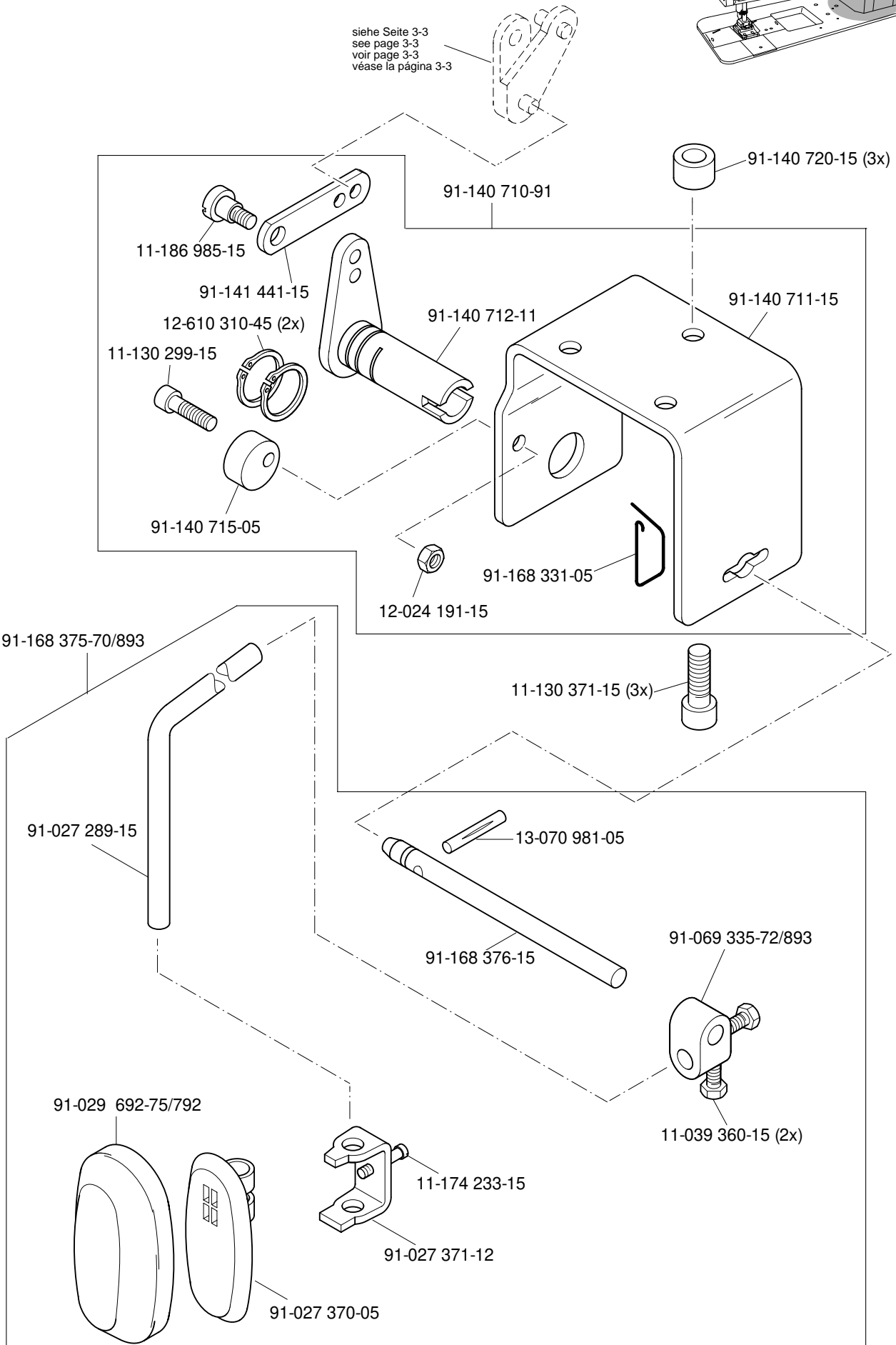

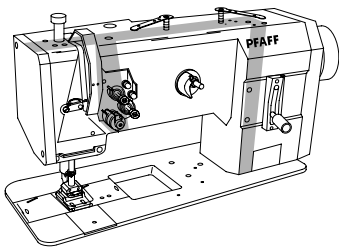

Fadenabschneid-Einrichtung (-900/56)
 Thread trimmer (-900/56)
 Coupe-fil (-900/56)
 Cortahilos (-900/56)

PFAFF 1242
 PFAFF 1242

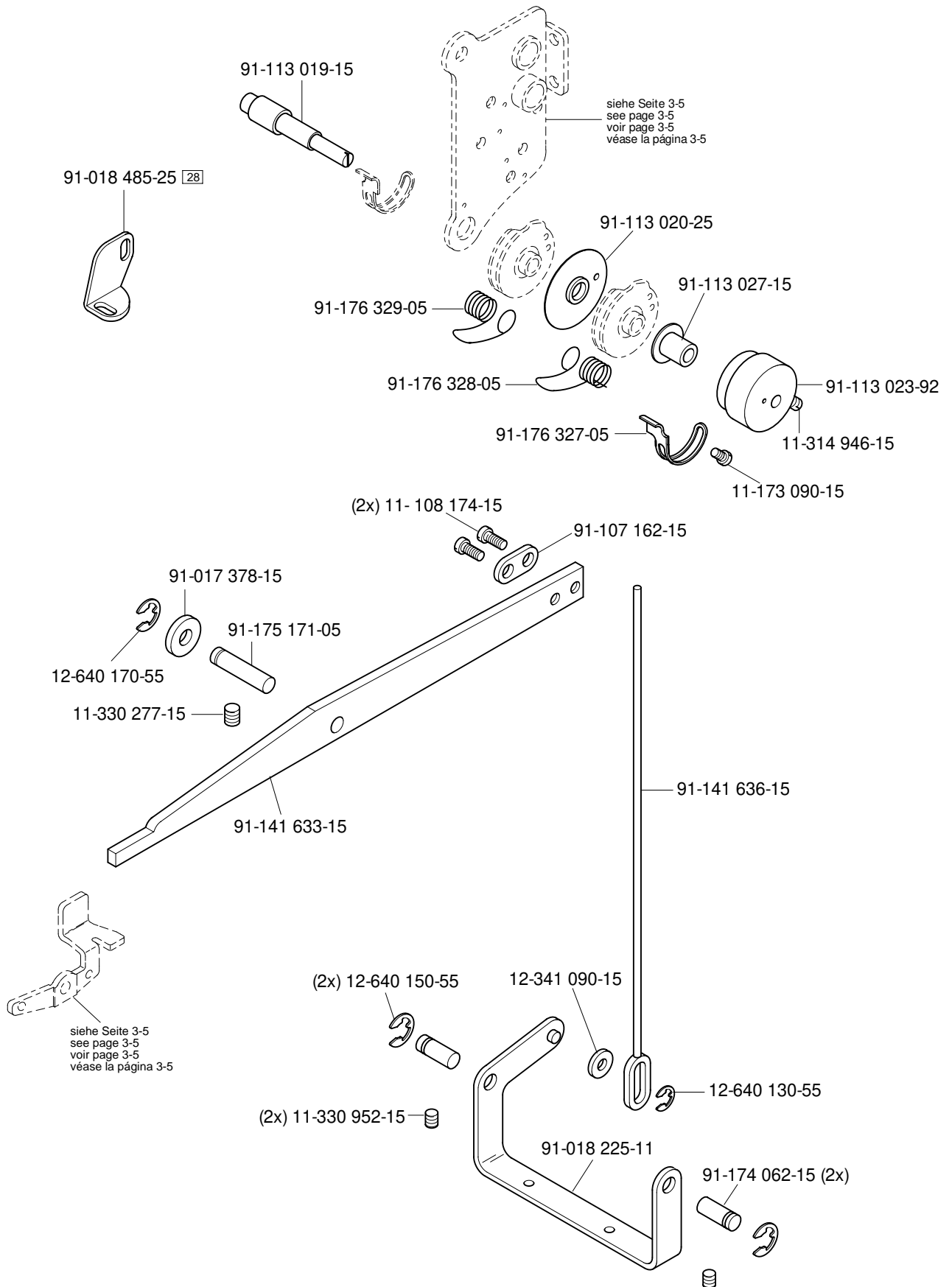

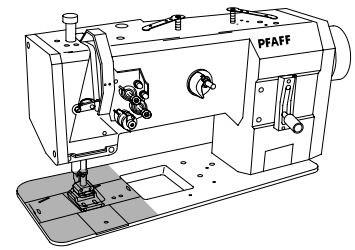

- ▣ 91-140 544-91 (PFAFF 242)
- 28/7 ▣ 91-140 545-91 (PFAFF 242)
- ▣ 91-140 540-91 (PFAFF 1242)
- ▣ 91-140 451-91 (PFAFF 1242)

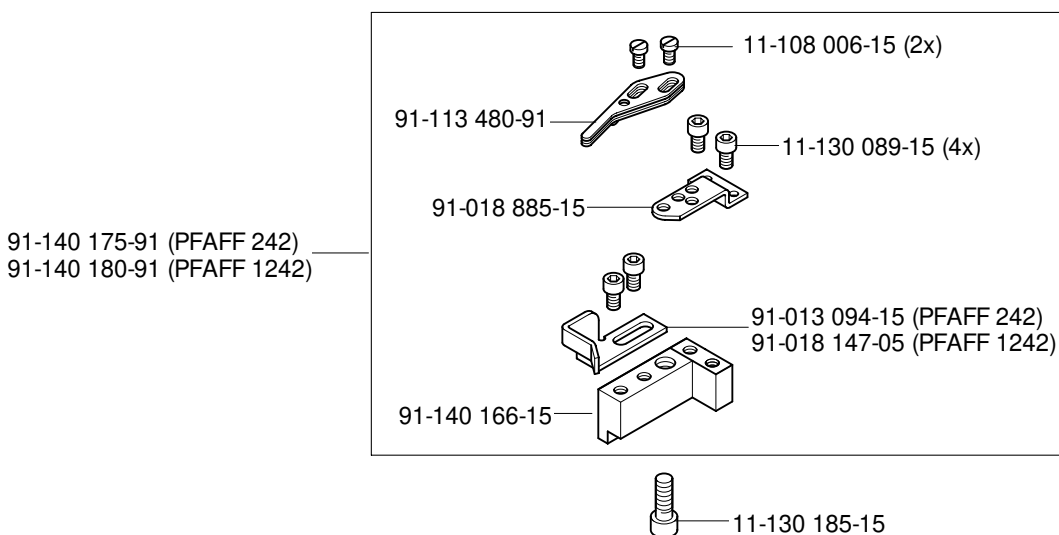
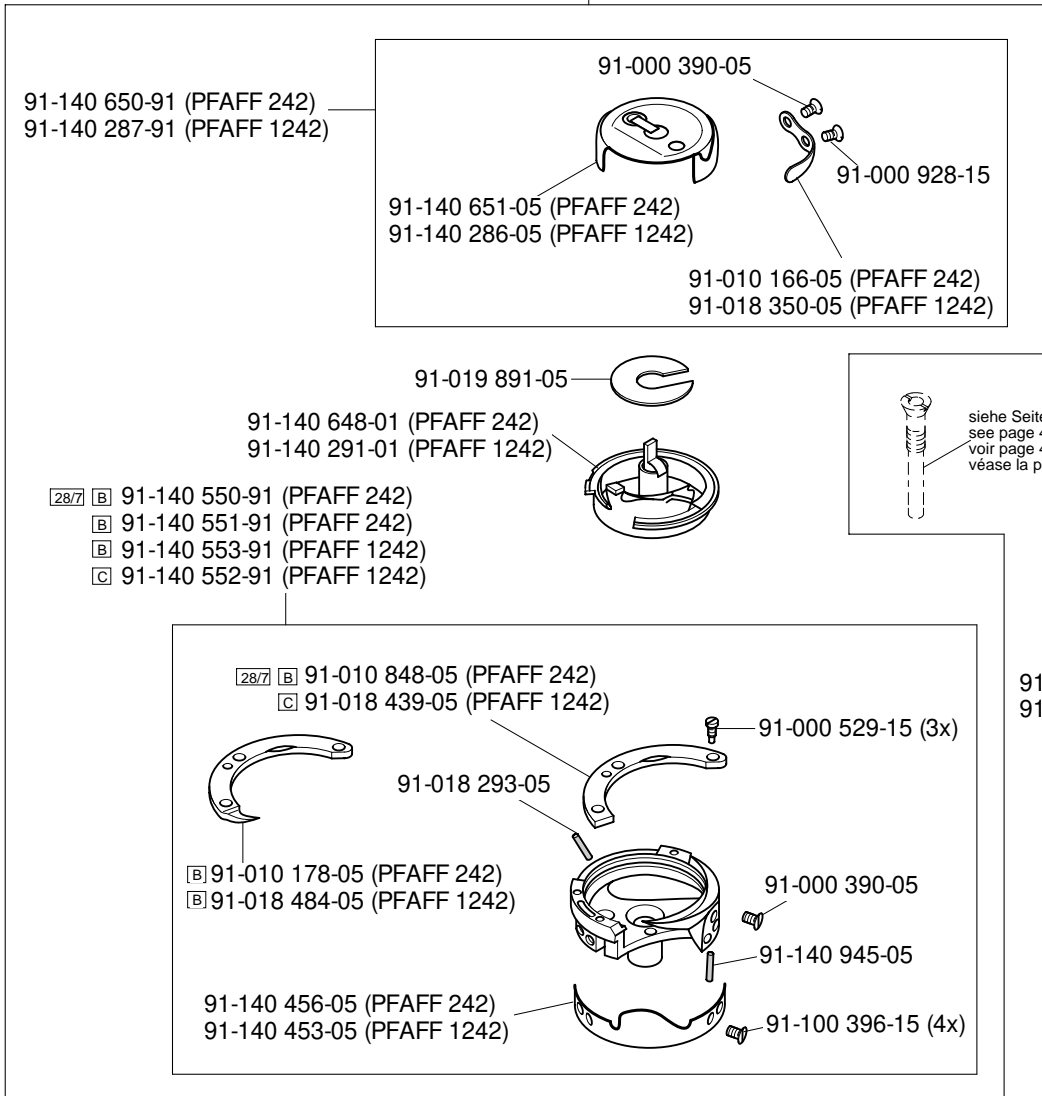

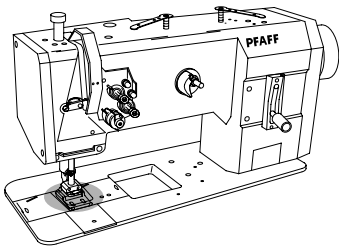

Fadenabschneid-Einrichtung (-900/56)
 Thread trimmer (-900/56)
 Coupe-fil (-900/56)
 Cortahilos (-900/56)

PFAFF 1242
 PFAFF 1242

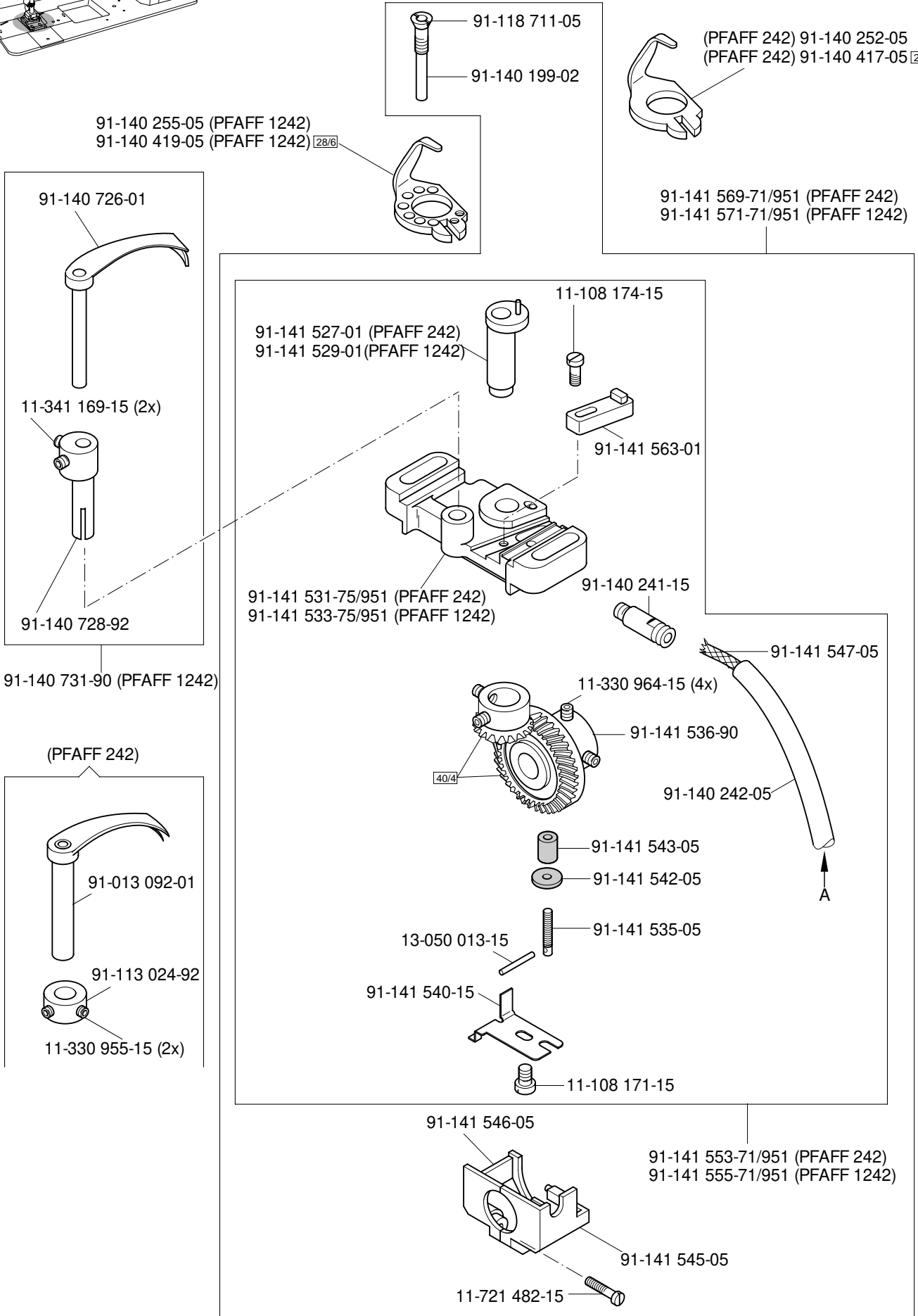

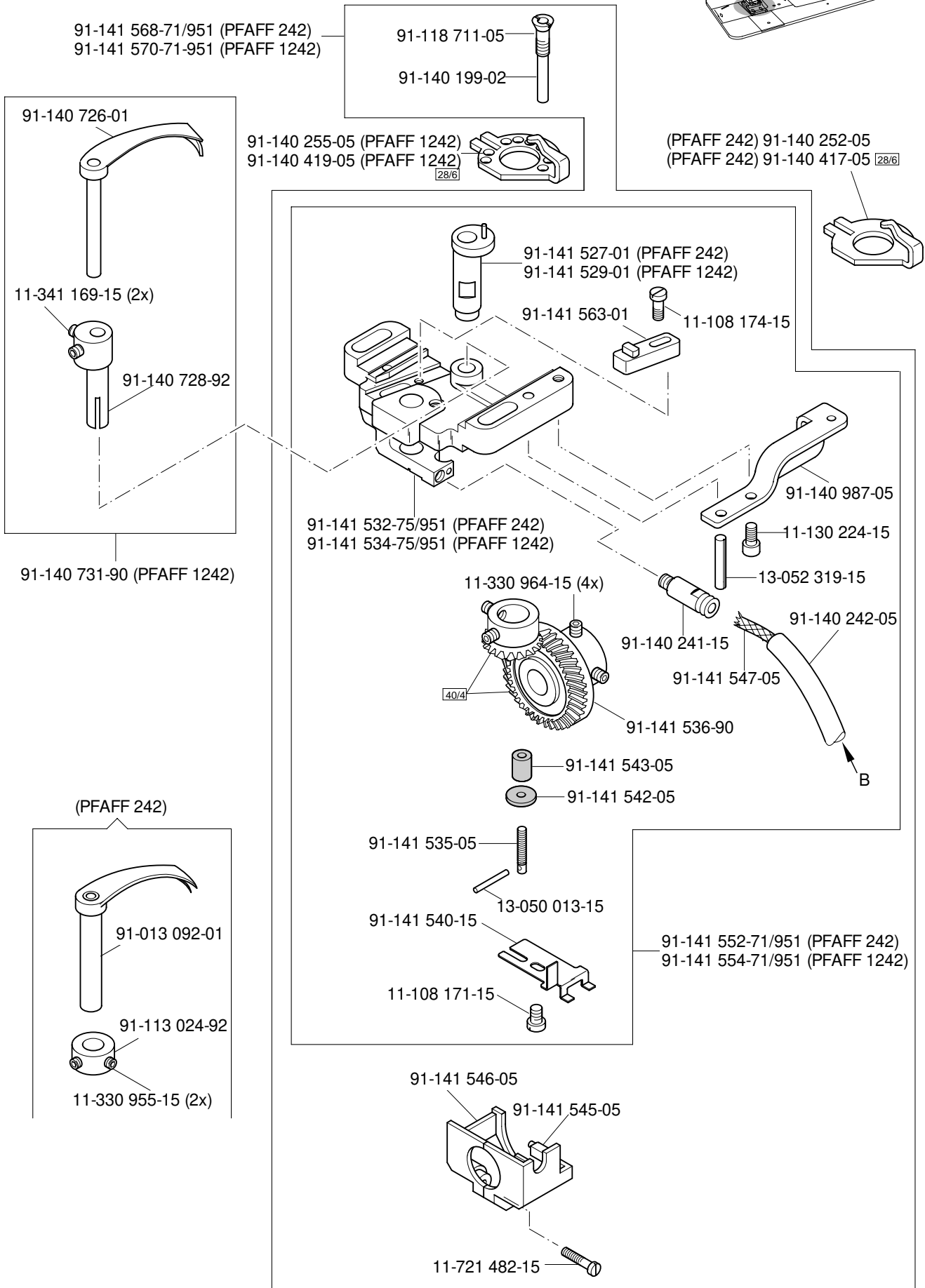
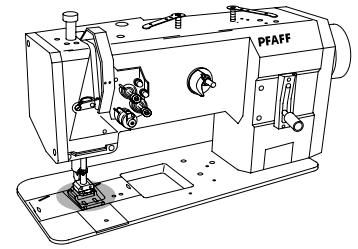

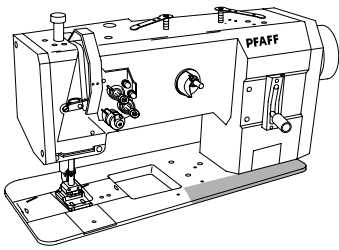

Fadenabschneid-Einrichtung (-900/56)
 Thread trimmer (-900/56)
 Coupe-fil (-900/56)
 Cortahilos (-900/56)

PFAFF 1242
 PFAFF 1242

siehe Seite 4-3 und 4-4
 see page 4-3 and 4-4
 voir page 4-3 et 4-4
 véase la página 4-3 y 4-4

siehe Seite 4-6
 see page 4-6
 voir page 4-6
 véase la página 4-6

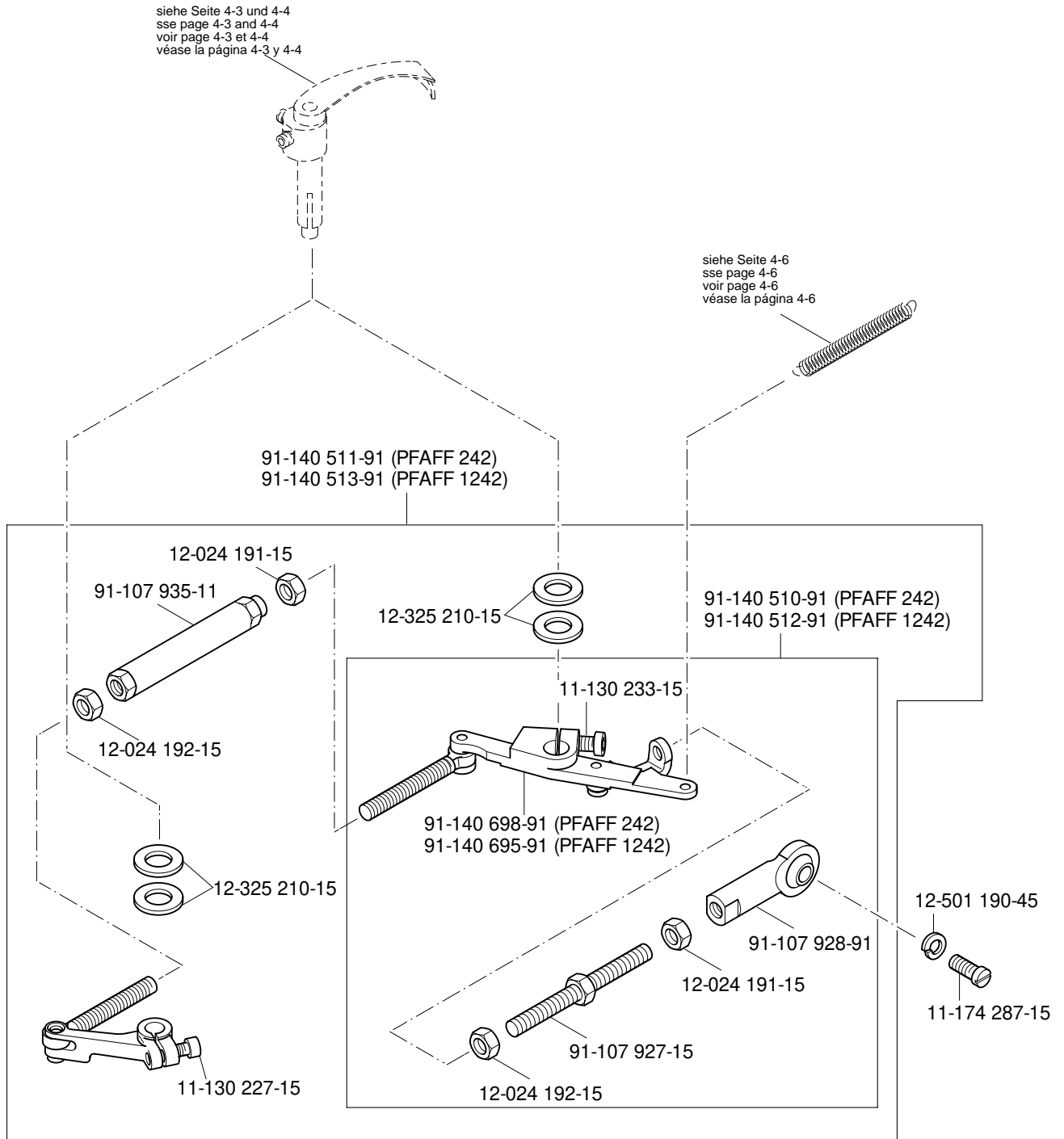

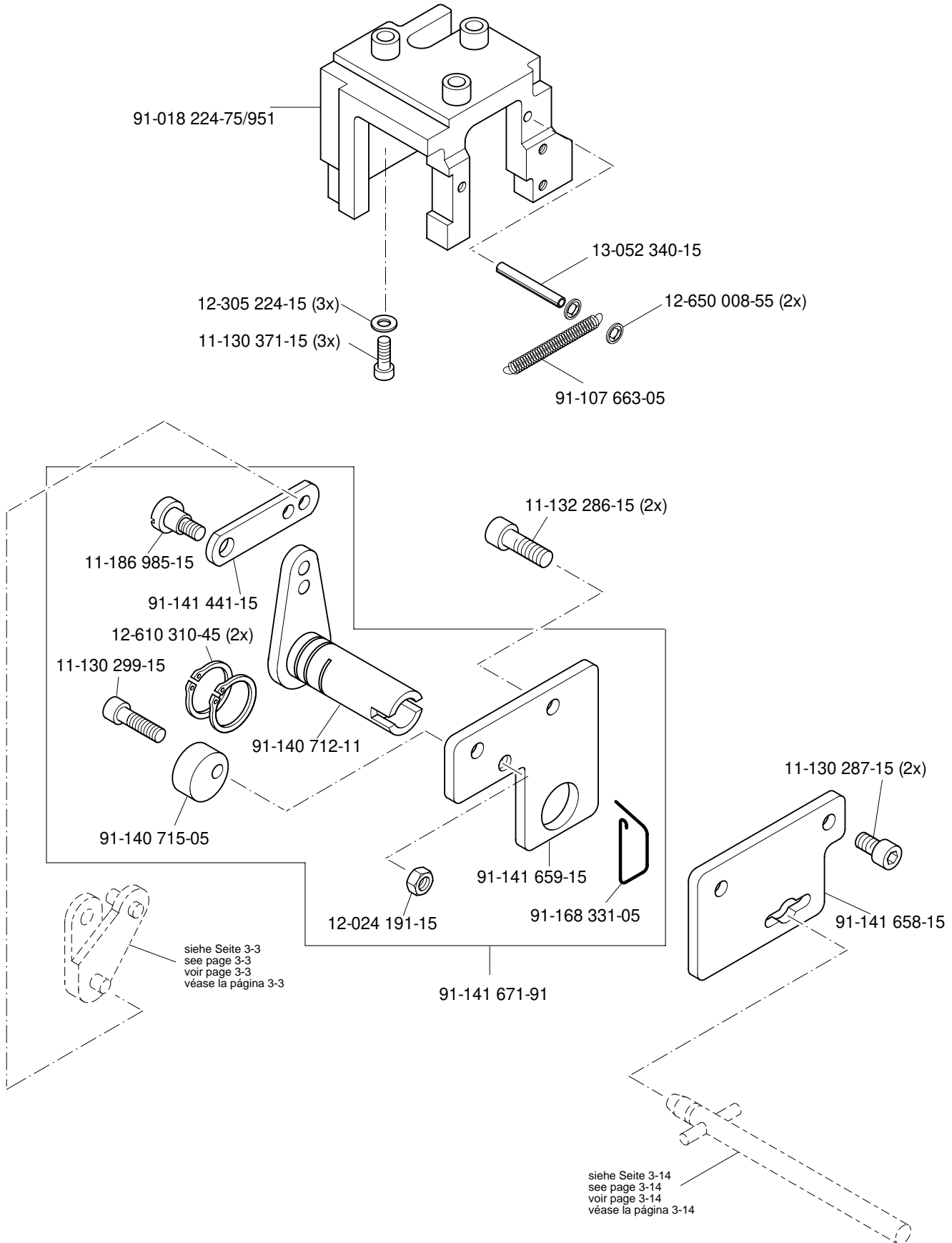
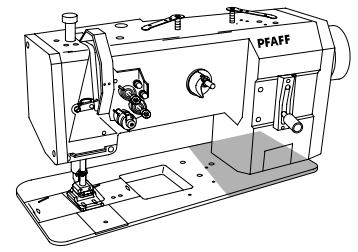

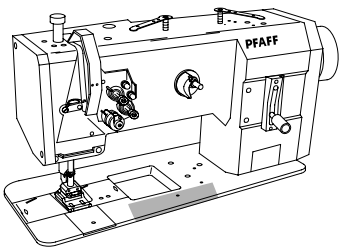

Fadenabschneid-Einrichtung (-900/56)
 Thread trimmer (-900/56)
 Coupe-fil (-900/56)
 Cortahilos (-900/56)

PFAFF 1242
 PFAFF 1242

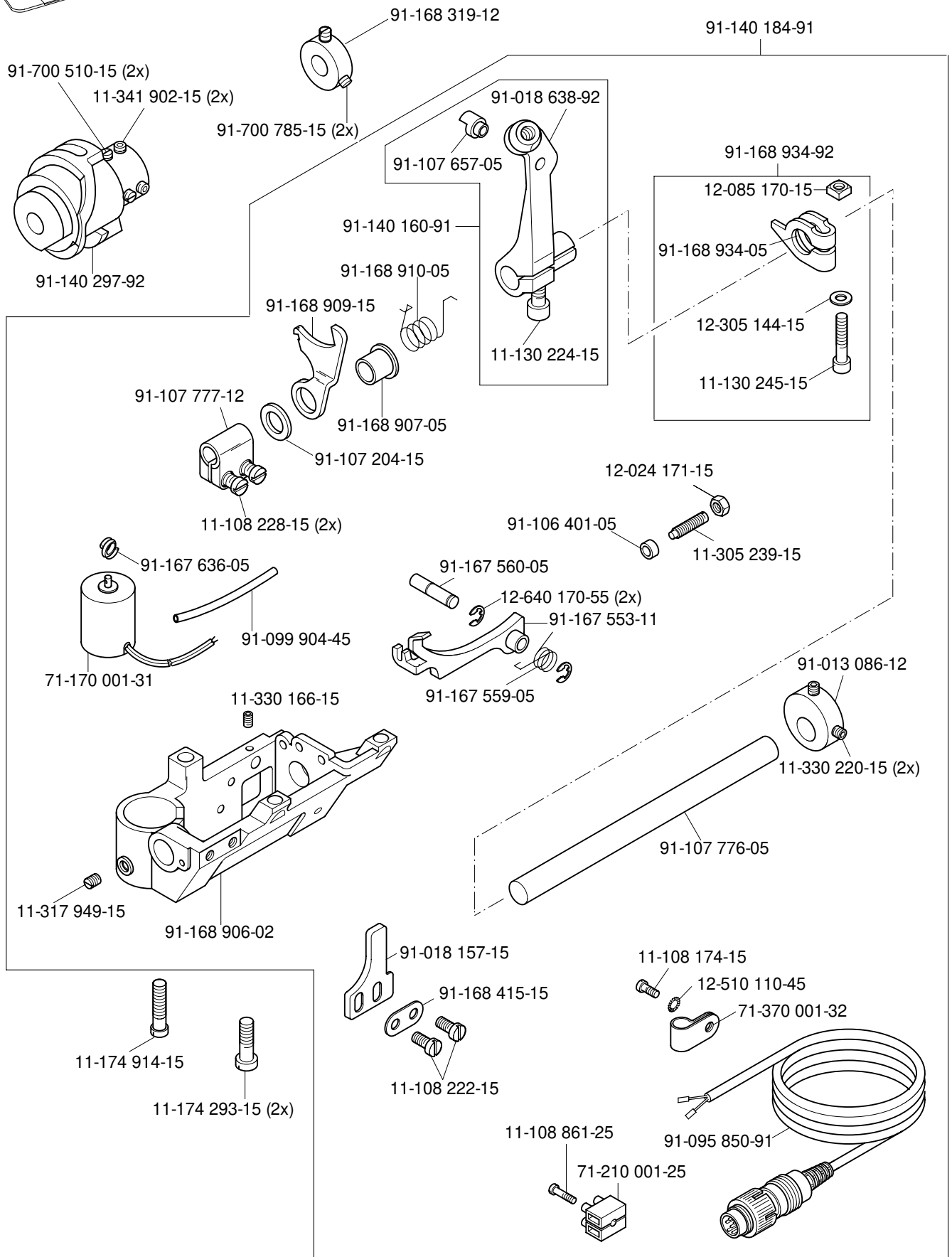

5

Presserfuß-Automatik (-910/98)
 Automatic presser foot lifter (-910/98)
 Relève-pied automatique (-910/98)
 Alzaprensatelas (-910/98)

PFAFF 1242
 PFAFF 1242

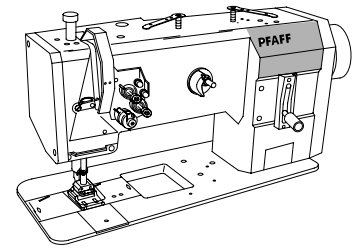

Wartungseinheit -925/03 erforderlich
 Conditioning unit -925/03 required
 Conditionneur d'air comprimé -925/03 nécessaire
 Requiere grupo acondicionador del aire comprimido -925/03

siehe Seite 3-3
 see page 3-3
 voir page 3-3
 véase la página 3-3

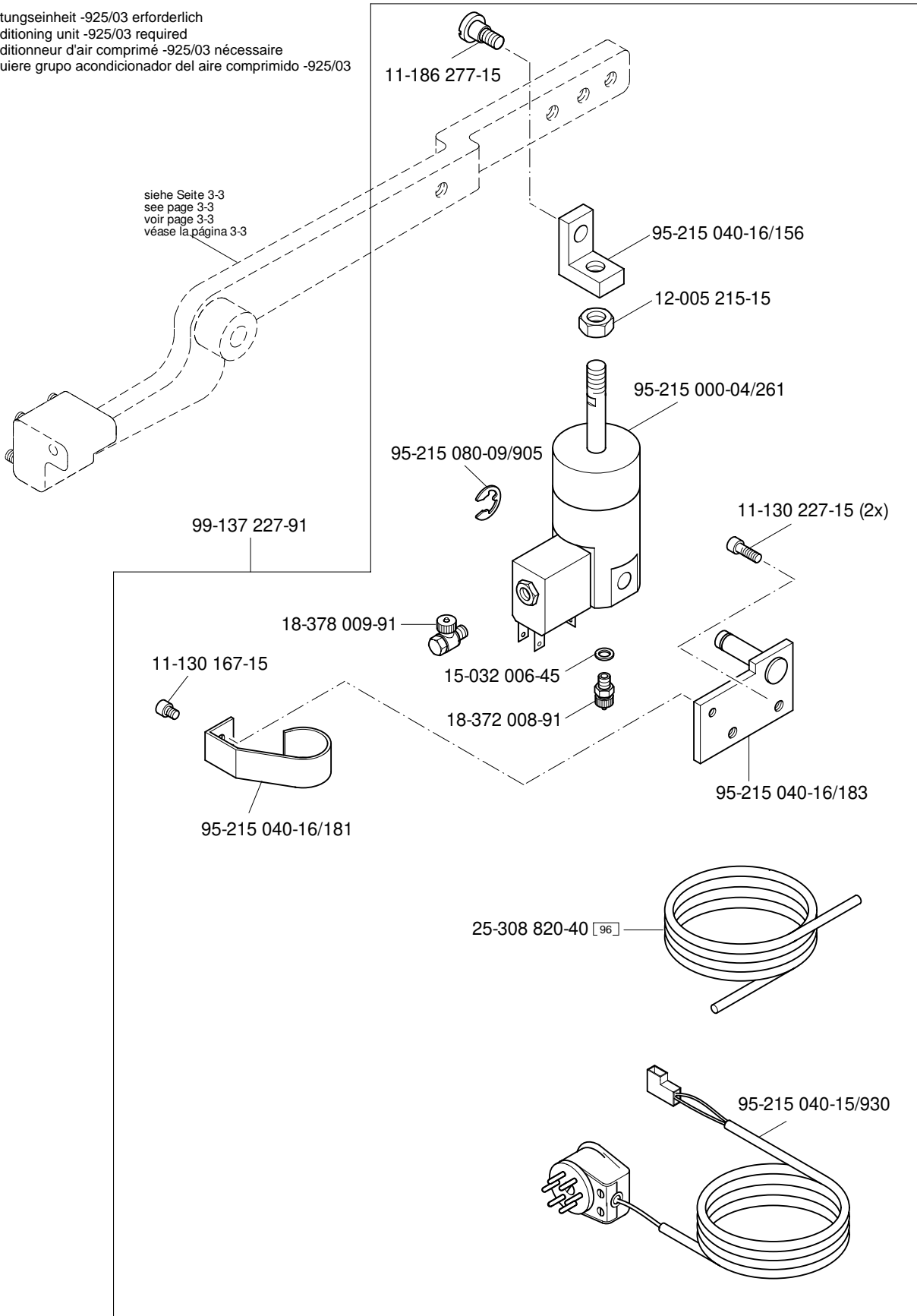

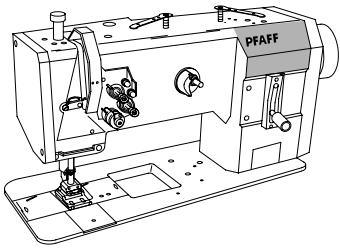

Verriegelungs-Einrichtung (-911/97)
 Backtacking mechanism (-911/97)
 Dispositif à points d'arrêt (-911/97)
 Rematador (-911/97)

PFAFF 1242
 PFAFF 1242

Wartungseinheit -925/03 erforderlich
 Conditioning unit -925/03 required
 Conditionneur d'air comprimé -925/03 nécessaire
 Requiere grupo acondicionador del aire comprimido -925/03

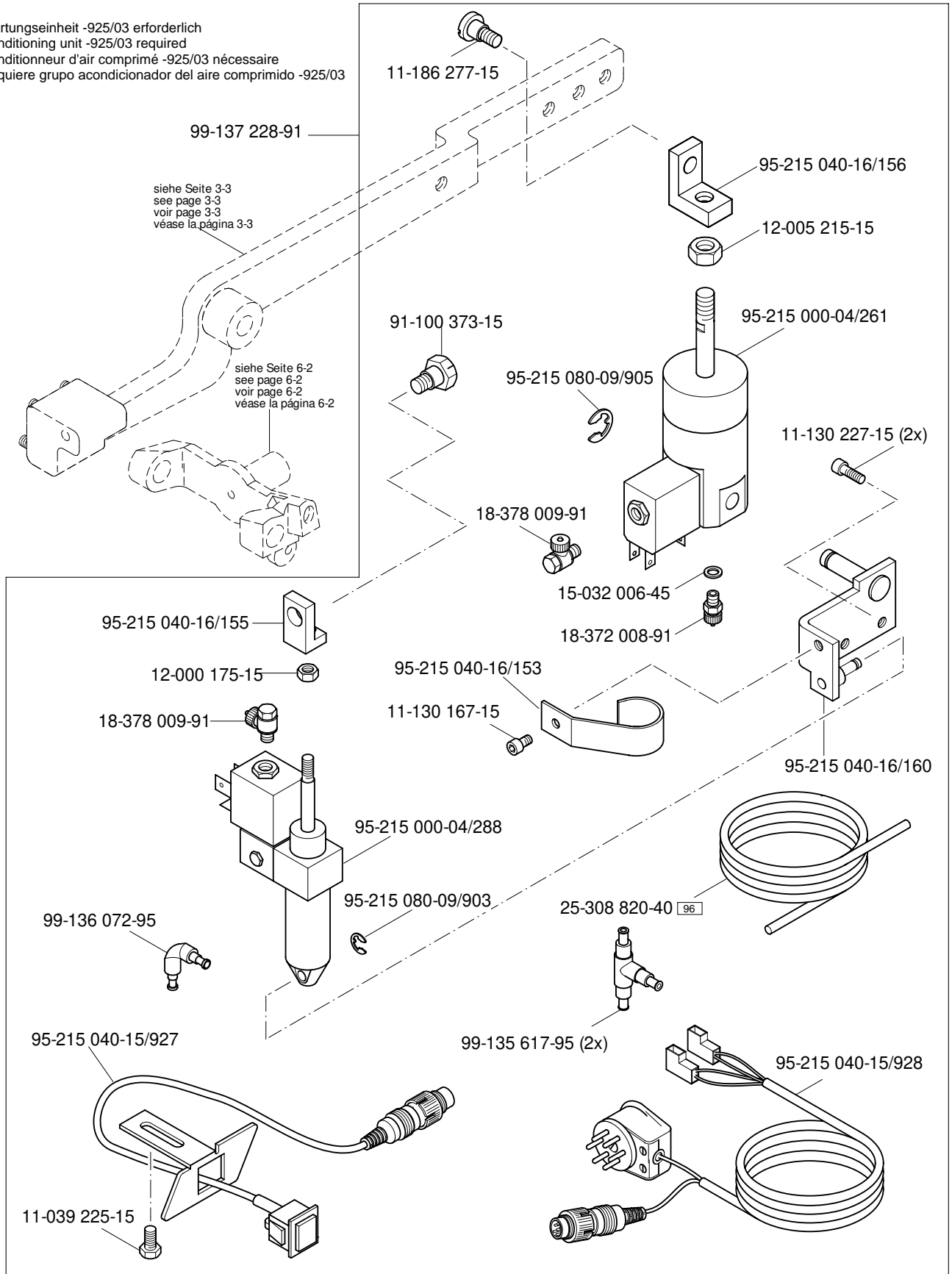

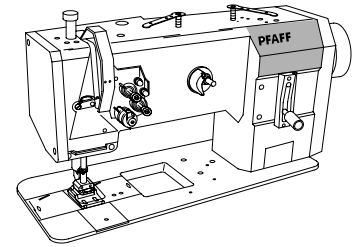

Wartungseinheit -925/03 erforderlich
 Conditioning unit -925/03 required
 Conditionneur d'air comprimé -925/03 nécessaire
 Requiere grupo acondicionador del aire comprimido -925/03

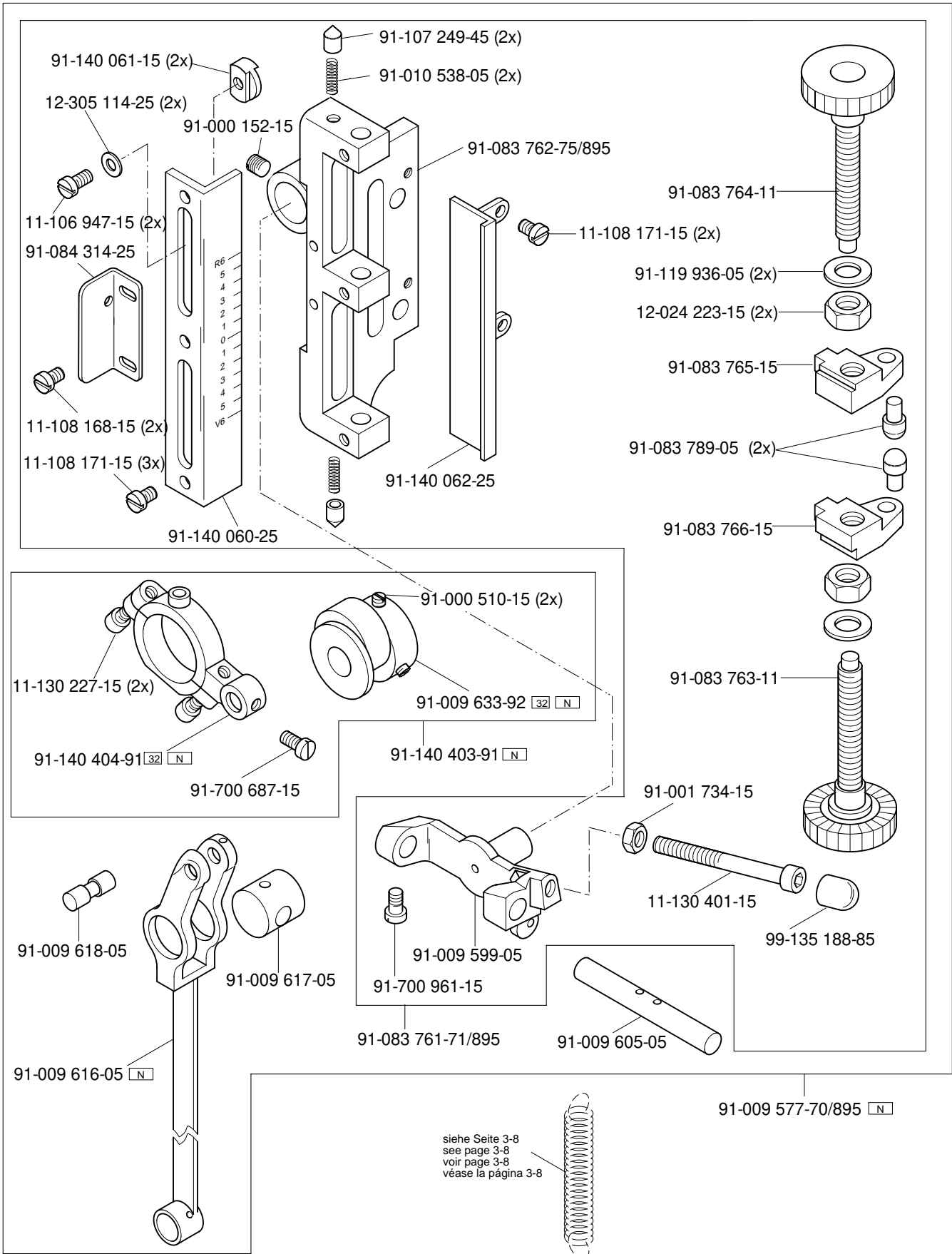

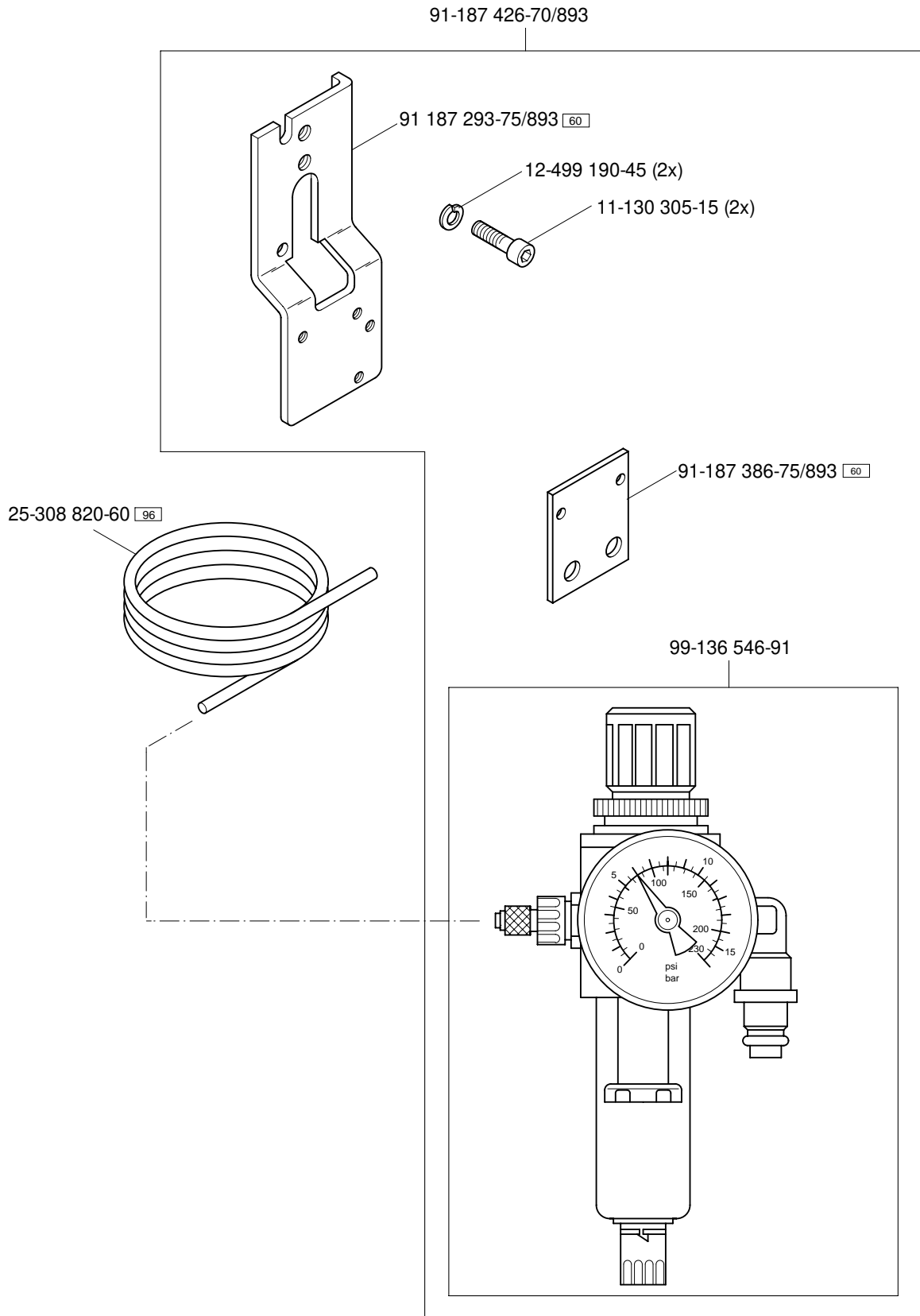

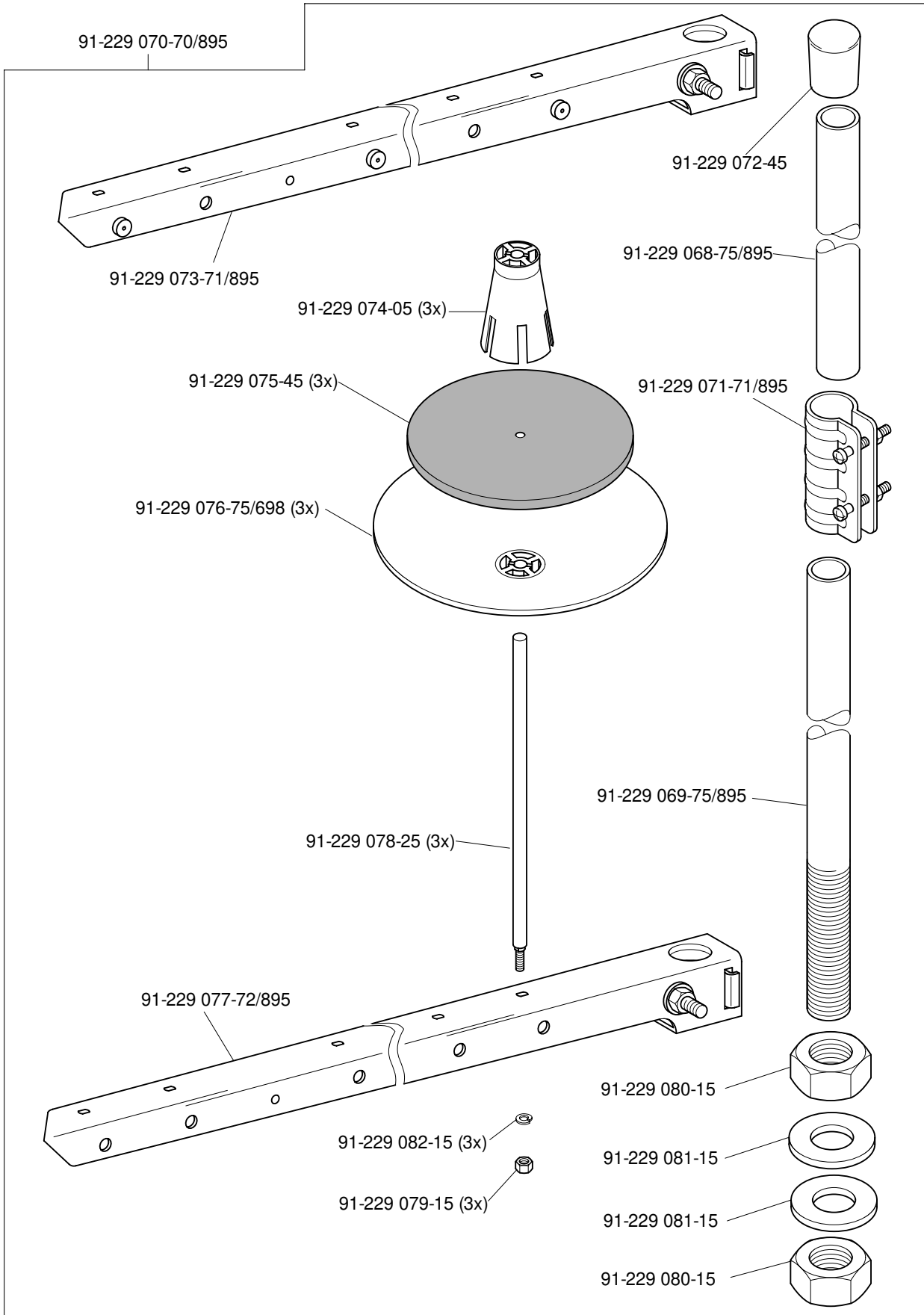

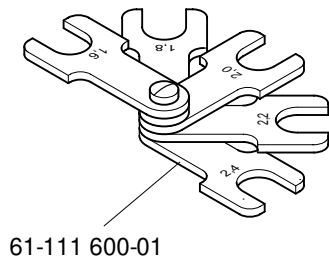

61-111 600-01

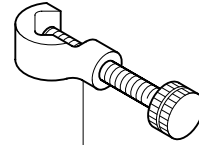

61-111 600-35

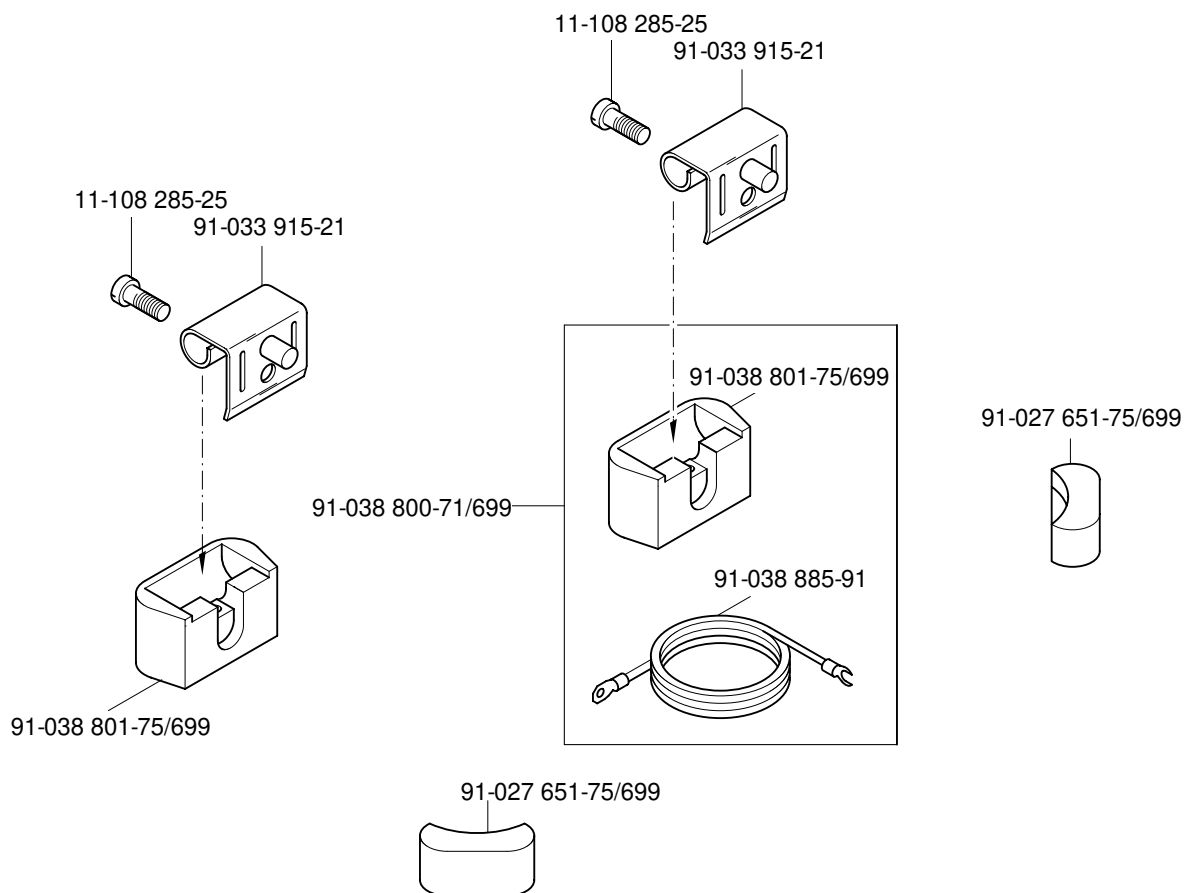

11

Fadenöler
Thread lubricator
Graisseur de fil PFAFF 1242
Lubricador del hilo PFAFF 1242

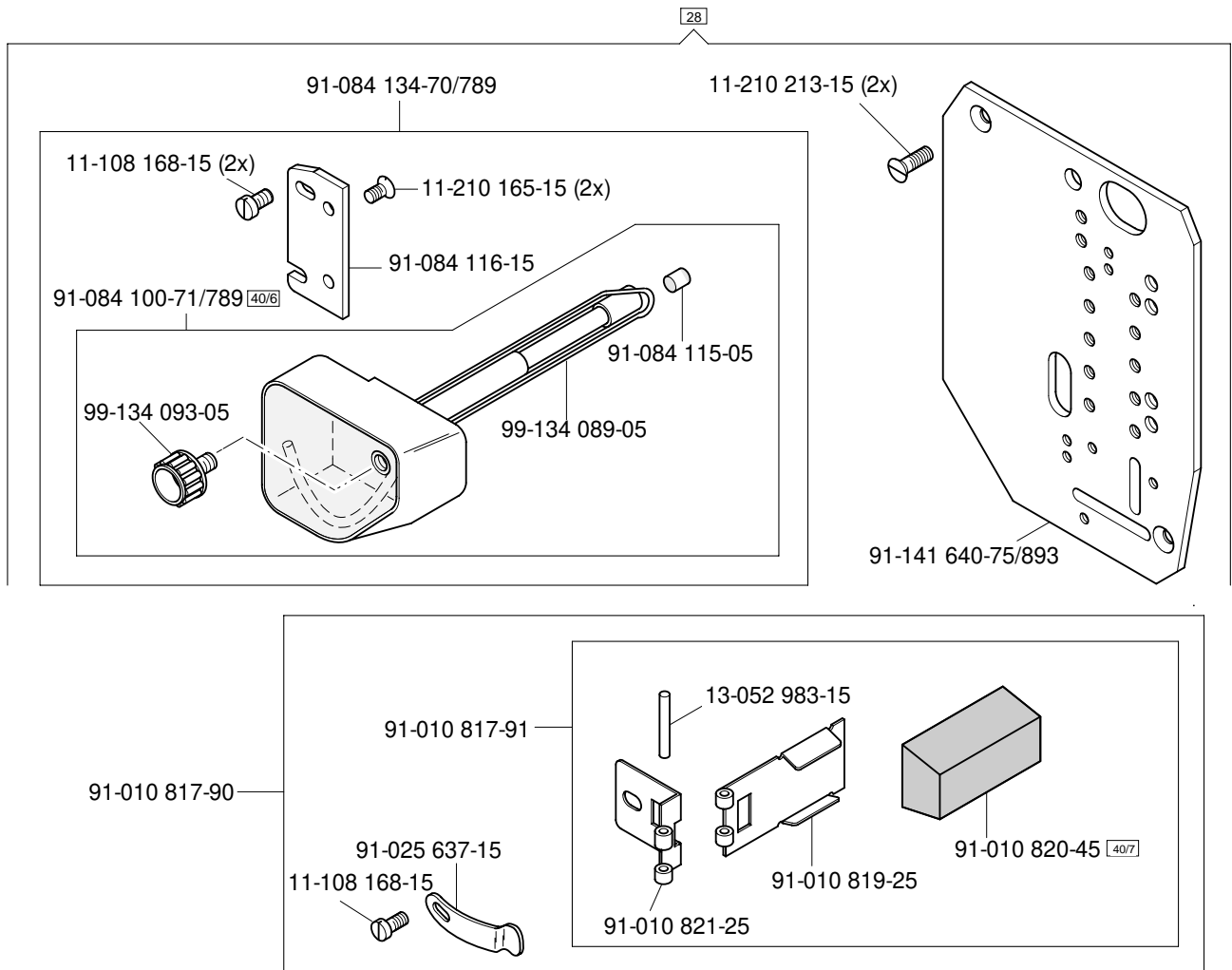

12

Keilriemen
V-belt
Courroie trapézoïdale PFAFF 1242
Correa trapezoidal PFAFF 1242

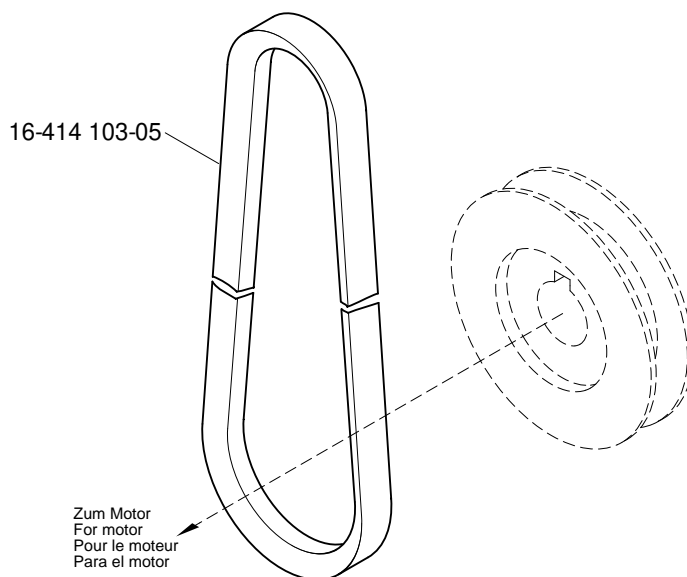

| Öl Oil Huile Aceite | Mittelpunkts- Viskosität bei: Mean viscosity at: Viscosité moyenne à: Viscosidad media a: | | Dichte bei: Density of: Densité à: Densidad a: | | Bestellnummer für Behälter mit: Part number for can with: Numéro de commande pour récipients avec: Número de pedido para recipientes con: | | |
|---|---|--------------------|---|-----------------------------|--|--------------------------------|-----------------------------------|
| | °C | mm ² /s | °C | g/cm ³ (g/ml) | 1 Liter 1 Litre 1 Litro | 5 Liter 5 Litre 5 Litros | 10 Liter 10 Litre 10 Litros |
| 28-011-201-44 | 40 | 22,0 | 15 | 0,865 | 91-129 917-91 | 91-129 919-91 | 91-129 920-91 |
| 28-011-202-17 (Fadenschmiermittel) (Thread lubricant) (Agents de (lubrification de fil) (Lubricantes del hilo) | | | 21 | 0,810 | 91-129 941-91 | | |

| Fett Grease Graisse Grasa | Penetration Penetration Pénétration Penetración | Tropfpunkt Drip-point Point de suintement Punto de goteo | Bestellnummer für Behälter mit: Part number for can with: Numéro de commande pour récipients avec: Número de pedido para recipientes con: | | |
|------------------------------------|--|---|--|----|---------------|
| | | | mm/10 | °C | 0,25 kg |
| 28-011-202-05 | | | | | 28-011-202-05 |
| 28-011-202-43 | 375-405 | 150 | | | 28-011-202-43 |
| 28-011-202-47 | 220-250 | 185 | | | 28-011-202-47 |

| Reinigungsmittel Cleansing agent Agents de nettoyage Limpiadores | Bestellnummer für Behälter mit: Part number for can with: Numéro de commande pour récipients avec: Número de pedido para recipientes con: | | |
|--|--|--|---------------|
| | | | 240 ml |
| 95-665 735-91 Isopropyl-Alkohol | | | 95-665 735-91 |

| No. | Seite Page Pages Página | No. | Seite Page Pages Página | No. | Seite Page Pages Página | No. | Seite Page Pages Página |
|---------------|--|---------------|----------------------------------|---------------|---|---------------|----------------------------------|
| 11-039 225-15 | 6 - 1 | 11-130 401-15 | 6 - 2 | 11-330 280-15 | 3 - 2, 3 - 4, 3 - 6, 3 - 12, 3 - 13 | 12-610 240-45 | 3 - 11 |
| 11-039 360-15 | 3 - 14 | 11-130 906-15 | 3 - 1 | 11-330 952-15 | 3 - 3, 4 - 1 | 12-610 310-45 | 3 - 14, 4 - 6 |
| 11-106 947-15 | 6 - 2 | 11-130 955-15 | 3 - 8 | 11-330 955-15 | 4 - 3, 4 - 4 | 12-640 130-55 | 3 - 6, 3 - 13, 4 - 1 |
| 11-108 006-15 | 4 - 2 | 11-132 286-15 | 4 - 6 | 11-330 962-15 | 3 - 12 | 12-640 150-55 | 3 - 13, 4 - 1 |
| 11-108 168-15 | 6 - 2, 11 - 1 | 11-173 090-15 | 4 - 1 | 11-330 964-15 | 3 - 10, 3 - 11, 4 - 3, 4 - 4 | 12-640 170-55 | 4 - 1, 4 - 7 |
| 11-108 171-15 | 3 - 10, 3 - 11, 4 - 3, 4 - 4, 6 - 2 | 11-173 171-25 | 3 - 1 | 11-330 968-15 | 3 - 6 | 12-650 008-55 | 4 - 6 |
| 11-108 174-15 | 3 - 1, 3 - 10, 3 - 11, 4 - 1, 4 - 3, 4 - 4, 4 - 7 | 11-173 222-25 | 3 - 1 | 11-335 902-15 | 3 - 7, 3 - 13 | 13-050 013-15 | 3 - 10, 3 - 11, 4 - 3, 4 - 4 |
| 11-108 222-15 | 4 - 7 | 11-174 173-15 | 3 - 2 | 11-341 169-15 | 4 - 3, 4 - 4 | 13-052 319-15 | 4 - 4 |
| 11-108 225-15 | 3 - 1, 3 - 12 | 11-174 233-15 | 3 - 5, 3 - 14 | 11-341 901-15 | 3 - 7, 3 - 13 | 13-052 340-15 | 4 - 6 |
| 11-108 228-15 | 3 - 12, 4 - 7 | 11-174 287-15 | 4 - 5 | 11-341 902-15 | 3 - 7, 3 - 13, 4 - 7 | 13-052 983-15 | 11 - 1 |
| 11-108 234-15 | 3 - 1 | 11-174 293-15 | 4 - 7 | 11-721 482-15 | 3 - 10, 3 - 11, 4 - 3, 4 - 4 | 13-064 383-05 | 3 - 8 |
| 11-108 285-15 | 3 - 1 | 11-174 914-15 | 4 - 7 | 12-000 175-15 | 6 - 1 | 13-070 981-05 | 3 - 14 |
| 11-108 285-25 | 9 - 1 | 11-186 277-15 | 5 - 1, 6 - 1 | 12-005 195-15 | 3 - 8 | 14-016 080-01 | 3 - 7 |
| 11-108 861-25 | 4 - 7 | 11-186 985-15 | 3 - 14, 4 - 6 | 12-005 215-15 | 5 - 1, 6 - 1 | 14-215 022-33 | 3 - 4 |
| 11-130 089-15 | 4 - 2 | 11-186 987-15 | 3 - 3 | 12-024 171-15 | 3 - 3, 4 - 7 | 14-215 046-33 | 3 - 4 |
| 11-130 167-15 | 5 - 1, 6 - 1 | 11-187 017-15 | 3 - 3 | 12-024 191-15 | 3 - 14, 4 - 5, 4 - 6 | 14-215 049-33 | 3 - 13 |
| 11-130 173-15 | 3 - 1, 3 - 2 | 11-210 165-15 | 11 - 1 | 12-024 191-25 | 3 - 7 | 14-602 901-01 | 3 - 6 |
| 11-130 185-15 | 3 - 2, 4 - 2 | 11-210 165-25 | 3 - 5 | 12-024 192-15 | 4 - 5 | 15-032 006-45 | 5 - 1, 6 - 1 |
| 11-130 224-15 | 4 - 4, 4 - 7 | 11-210 168-25 | 3 - 6 | 12-024 223-15 | 6 - 2 | 16-410 918-05 | 3 - 7 |
| 11-130 227-15 | 3 - 7, 3 - 8, 4 - 5, 5 - 1, 6 - 1, 6 - 2 | 11-210 213-15 | 11 - 1 | 12-085 170-15 | 4 - 7 | 16-414 103-05 | 11 - 1 |
| 11-130 233-15 | 4 - 5 | 11-210 273-15 | 3 - 7 | 12-305 114-15 | 3 - 2 | 18-372 008-91 | 5 - 1, 6 - 1 |
| 11-130 245-15 | 4 - 7 | 11-250 084-25 | 3 - 6, 3 - 8 | 12-305 114-25 | 6 - 2 | 18-378 009-91 | 5 - 1, 6 - 1 |
| 11-130 254-15 | 3 - 1 | 11-305 239-15 | 4 - 7 | 12-305 144-15 | 3 - 7, 4 - 7 | 25-308 820-40 | 5 - 1, 6 - 1 |
| 11-130 284-15 | 3 - 8 | 11-314 082-15 | 3 - 2 | 12-305 224-15 | 4 - 6 | 25-308 820-60 | 7 - 1 |
| 11-130 287-15 | 3 - 1, 4 - 6 | 11-314 946-15 | 4 - 1 | 12-325 210-15 | 4 - 5 | 26-534 300-50 | 3 - 4, 3 - 6, 3 - 8 |
| 11-130 293-25 | 3 - 8 | 11-315 917-05 | 3 - 6 | 12-335 151-15 | 3 - 1 | 26-535 001-00 | 3 - 4 |
| 11-130 299-15 | 3 - 14, 4 - 6 | 11-317 167-15 | 3 - 5 | 12-341 090-15 | 4 - 1 | 28-011 201-44 | 13 - 1 |
| 11-130 305-15 | 3 - 10, 3 - 11, 7 - 1 | 11-317 949-15 | 4 - 7 | 12-341 150-15 | 3 - 10, 3 - 11 | 28-011 202-05 | 13 - 1 |
| 11-130 359-15 | 3 - 6 | 11-330 166-15 | 3 - 8, 4 - 7 | 12-499 190-45 | 7 - 1 | 28-011 202-17 | 13 - 1 |
| 11-130 371-15 | 3 - 14, 4 - 6 | 11-330 217-15 | 3 - 13 | 12-501 190-45 | 4 - 5 | 28-011 202-43 | 13 - 1 |
| | | 11-330 220-15 | 3 - 2, 3 - 5, 4 - 7 | 12-510 110-45 | 4 - 7 | 28-011 202-47 | 13 - 1 |
| | | 11-330 277-15 | 4 - 1 | 12-510 171-45 | 3 - 1 | 61-111 600-01 | 9 - 1 |

| No. | Seite Page Pages Página | No. | Seite Page Pages Página | No. | Seite Page Pages Página | No. | Seite Page Pages Página |
|---------------|----------------------------------|-------------------|----------------------------------|---------------|----------------------------------|-------------------|----------------------------------|
| 61-111 600-35 | 9 - 1 | 91-006 616-05 | 3 - 6, 3 - 8 | 91-010 126-92 | 3 - 12 | 91-013 092-01 | 4 - 3, 4 - 4 |
| 71-170 001-31 | 4 - 7 | 91-007 015-05 | 3 - 4 | 91-010 146-92 | 3 - 12 | 91-013 094-15 | 4 - 2 |
| 71-210 001-25 | 4 - 7 | 91-008 470-05 | 3 - 6 | 91-010 157-01 | 3 - 9 | 91-013 153-05 | 3 - 13 |
| 71-370 001-32 | 4 - 7 | 91-008 618-05 | 3 - 6, 3 - 8 | 91-010 158-05 | 3 - 9 | 91-013 188-05 | 3 - 13 |
| 91-000 011-15 | 3 - 6 | 91-009 118-01 | 3 - 2 | 91-010 159-91 | 3 - 9 | 91-013 191-05 | 3 - 5 |
| 91-000 073-25 | 3 - 2 | 91-009 119-05 | 3 - 2 | 91-010 166-05 | 3 - 9, 4 - 2 | 91-013 193-91 | 3 - 5 |
| 91-000 152-15 | 6 - 2 | 91-009 148-05 | 3 - 4 | 91-010 178-05 | 3 - 9, 4 - 2 | 91-015 519-05 | 3 - 5 |
| 91-000 243-15 | 3 - 4 | 91-009 149-05 | 3 - 12 | 91-010 179-05 | 3 - 5 | 91-015 664-05 | 3 - 12 |
| 91-000 366-15 | 3 - 5 | 91-009 343-05 | 3 - 13 | 91-010 180-05 | 3 - 5 | 91-017 378-15 | 4 - 1 |
| 91-000 390-05 | 3 - 9, 4 - 2 | 91-009 359-91 | 3 - 12 | 91-010 181-25 | 3 - 5 | 91-018 136-12 | 3 - 12 |
| 91-000 407-15 | 3 - 9 | 91-009 408-05 | 3 - 13 | 91-010 183-05 | 3 - 5 | 91-018 147-05 | 4 - 2 |
| 91-000 422-15 | 3 - 9 | 91-009 498-70/895 | 3 - 8 | 91-010 184-05 | 3 - 5 | 91-018 157-15 | 4 - 7 |
| 91-000 503-15 | 3 - 12 | 91-009 499-71/895 | 3 - 8 | 91-010 185-05 | 3 - 5 | 91-018 224-75/951 | 4 - 6 |
| 91-000 510-15 | 3 - 8, 6 - 2 | 91-009 577-70/895 | 6 - 2 | 91-010 186-15 | 3 - 5 | 91-018 225-11 | 4 - 1 |
| 91-000 522-15 | 3 - 8 | 91-009 599-05 | 6 - 2 | 91-010 196-05 | 3 - 6 | 91-018 293-05 | 3 - 9, 4 - 2 |
| 91-000 524-05 | 3 - 5 | 91-009 602-02 | 3 - 8 | 91-010 211-05 | 3 - 12 | 91-018 339-05 | 3 - 9 |
| 91-000 529-15 | 3 - 9, 4 - 2 | 91-009 603-75/895 | 3 - 8 | 91-010 221-05 | 3 - 12 | 91-018 346-01 | 3 - 9 |
| 91-000 865-15 | 3 - 2 | 91-009 605-05 | 3 - 8, 6 - 2 | 91-010 223-92 | 3 - 12 | 91-018 348-91 | 3 - 9 |
| 91-000 928-15 | 3 - 9, 4 - 2 | 91-009 609-05 | 3 - 8 | 91-010 538-05 | 6 - 2 | 91-018 349-05 | 3 - 9 |
| 91-001 013-15 | 3 - 6 | 91-009 616-05 | 3 - 8, 6 - 2 | 91-010 596-05 | 3 - 6, 3 - 8 | 91-018 350-05 | 3 - 9, 4 - 2 |
| 91-001 512-15 | 3 - 6, 3 - 8 | 91-009 617-05 | 3 - 8, 6 - 2 | 91-010 633-05 | 3 - 2 | 91-018 358-75/770 | 3 - 6 |
| 91-001 522-25 | 3 - 5 | 91-009 618-05 | 3 - 8, 6 - 2 | 91-010 734-15 | 3 - 2 | 91-018 439-05 | 3 - 9, 4 - 2 |
| 91-001 536-15 | 3 - 12 | 91-009 624-05 | 3 - 8 | 91-010 817-90 | 11 - 1 | 91-018 480-05 | 4 - 2 |
| 91-001 734-15 | 6 - 2 | 91-009 633-92 | 3 - 8, 6 - 2 | 91-010 817-91 | 11 - 1 | 91-018 484-05 | 3 - 9, 4 - 2 |
| 91-003 113-05 | 3 - 1 | 91-009 648-25 | 3 - 8 | 91-010 819-25 | 11 - 1 | 91-018 485-25 | 4 - 1 |
| 91-004 005-05 | 3 - 5 | 91-010 006-92 | 3 - 4 | 91-010 820-45 | 11 - 1 | 91-018 487-05 | 3 - 6 |
| 91-004 006-05 | 3 - 5 | 91-010 013-05 | 3 - 6 | 91-010 821-25 | 11 - 1 | 91-018 515-01 | 3 - 6, 3 - 8 |
| 91-004 186-15 | 3 - 12 | 91-010 026-21 | 3 - 5 | 91-010 848-05 | 3 - 9, 4 - 2 | 91-018 638-92 | 4 - 7 |
| 91-005 673-05 | 3 - 12 | 91-010 062-72/895 | 3 - 9 | 91-011 238-05 | 3 - 8 | 91-018 799-91 | 3 - 5 |
| 91-006 505-05 | 3 - 5 | 91-010 079-05 | 3 - 9 | 91-013 040-92 | 3 - 6 | 91-018 885-15 | 4 - 2 |
| 91-006 525-05 | 3 - 2 | 91-010 115-05 | 3 - 5 | 91-013 086-12 | 4 - 7 | 91-019 676-05 | 3 - 6, 3 - 8 |
| 91-006 526-05 | 3 - 2 | 91-010 116-05 | 3 - 5 | 91-013 091-05 | 3 - 5 | 91-019 846-92 | 3 - 2 |

| No. | Seite Page Pages Página | No. | Seite Page Pages Página | No. | Seite Page Pages Página | No. | Seite Page Pages Página |
|-------------------|----------------------------------|---------------|----------------------------------|-------------------|----------------------------------|---------------|----------------------------------|
| 91-019 891-05 | 3 - 9, 4 - 2 | 91-084 314-25 | 6 - 2 | 91-118 308-05 | 4 - 2 | 91-140 148-05 | 3 - 13 |
| 91-025 637-15 | 11 - 1 | 91-095 850-91 | 4 - 7 | 91-118 430-25 | 3 - 5 | 91-140 155-11 | 3 - 1 |
| 91-027 370-05 | 3 - 14 | 91-099 904-45 | 4 - 7 | 91-118 681-05 | 3 - 6 | 91-140 160-91 | 4 - 7 |
| 91-027 371-12 | 3 - 14 | 91-100 213-05 | 3 - 4 | 91-118 683-05 | 3 - 6 | 91-140 166-15 | 4 - 2 |
| 91-027 651-75/699 | 9 - 1 | 91-100 281-25 | 3 - 6 | 91-118 685-05 | 3 - 6 | 91-140 175-91 | 4 - 2 |
| 91-029 289-15 | 3 - 14 | 91-100 373-15 | 6 - 1 | 91-118 711-05 | 3 - 10, 3 - 11, 4 - 3, 4 - 4 | 91-140 180-91 | 4 - 2 |
| 91-029 692-75/792 | 3 - 14 | 91-100 396-15 | 3 - 9, 4 - 2 | 91-118 940-05 | 3 - 6 | 91-140 184-91 | 4 - 7 |
| 91-032 087-45 | 3 - 1 | 91-100 404-15 | 3 - 9 | 91-119 590-05 | 3 - 8 | 91-140 199-02 | 3 - 10, 3 - 11, 4 - 3, 4 - 4 |
| 91-033 915-21 | 9 - 1 | 91-105 005-15 | 3 - 2 | 91-119 936-05 | 6 - 2 | 91-140 201-05 | 3 - 10 |
| 91-038 800-71/699 | 9 - 1 | 91-105 447-25 | 3 - 5 | 91-120 735-92 | 3 - 13 | 91-140 202-05 | 3 - 11 |
| 91-038 801-75/699 | 9 - 1 | 91-106 401-05 | 4 - 7 | 91-129 191-71/895 | 3 - 1 | 91-140 241-15 | 3 - 10, 3 - 11, 4 - 3, 4 - 4 |
| 91-038 885-91 | 9 - 1 | 91-107 162-15 | 4 - 1 | 91-129 917-91 | 13 - 1 | 91-140 242-05 | 3 - 10, 3 - 11, 4 - 3, 4 - 4 |
| 91-056 192-25 | 3 - 7 | 91-107 204-15 | 4 - 7 | 91-129 919-91 | 13 - 1 | 91-140 251-05 | 3 - 10, 3 - 11 |
| 91-056 193-25 | 3 - 7 | 91-107 249-45 | 6 - 2 | 91-129 920-91 | 13 - 1 | 91-140 252-05 | 4 - 3, 4 - 4 |
| 91-056 194-21 | 3 - 7 | 91-107 657-05 | 4 - 7 | 91-129 941-91 | 13 - 1 | 91-140 253-05 | 3 - 10, 3 - 11 |
| 91-056 578-91 | 3 - 7 | 91-107 663-05 | 4 - 6 | 91-140 060-25 | 6 - 2 | 91-140 255-05 | 4 - 3, 4 - 4 |
| 91-061 005-05 | 3 - 2 | 91-107 776-05 | 4 - 7 | 91-140 061-15 | 6 - 2 | 91-140 256-05 | 3 - 9 |
| 91-063 048-05 | 3 - 4 | 91-107 777-12 | 4 - 7 | 91-140 062-25 | 6 - 2 | 91-140 257-05 | 3 - 9 |
| 91-063 051-01 | 3 - 4 | 91-107 886-15 | 3 - 8 | 91-140 085-05 | 3 - 2 | 91-140 258-05 | 3 - 9 |
| 91-069 037-15 | 3 - 13 | 91-107 927-15 | 4 - 5 | 91-140 086-12 | 3 - 2 | 91-140 260-91 | 3 - 12 |
| 91-069 335-72/893 | 3 - 14 | 91-107 928-91 | 4 - 5 | 91-140 095-05 | 3 - 4 | 91-140 286-05 | 4 - 2 |
| 91-083 761-71/895 | 6 - 2 | 91-107 935-11 | 4 - 5 | 91-140 099-05 | 3 - 2 | 91-140 287-91 | 4 - 2 |
| 91-083 762-75/895 | 6 - 2 | 91-108 015-02 | 3 - 6 | 91-140 101-05 | 3 - 6 | 91-140 291-01 | 4 - 2 |
| 91-083 763-11 | 6 - 2 | 91-113 017-91 | 3 - 5 | 91-140 102-05 | 3 - 6 | 91-140 297-92 | 4 - 7 |
| 91-083 764-11 | 6 - 2 | 91-113 019-15 | 4 - 1 | 91-140 104-05 | 3 - 13 | 91-140 300-01 | 3 - 11 |
| 91-083 765-15 | 6 - 2 | 91-113 020-25 | 4 - 1 | 91-140 111-01 | 3 - 4 | 91-140 336-15 | 3 - 3 |
| 91-083 766-15 | 6 - 2 | 91-113 023-92 | 4 - 1 | 91-140 120-05 | 3 - 7 | 91-140 403-91 | 3 - 8, 6 - 2 |
| 91-083 789-05 | 6 - 2 | 91-113 024-92 | 4 - 3, 4 - 4 | 91-140 121-91 | 3 - 7 | 91-140 404-91 | 3 - 8, 6 - 2 |
| 91-084 100-71/789 | 11 - 1 | 91-113 027-15 | 4 - 1 | 91-140 122-91 | 3 - 13 | 91-140 413-05 | 3 - 9 |
| 91-084 115-05 | 11 - 1 | 91-113 480-91 | 4 - 2 | 91-140 123-91 | 3 - 7 | 91-140 414-04 | 3 - 9 |
| 91-084 116-15 | 11 - 1 | 91-118 099-91 | 3 - 6 | 91-140 124-11 | 3 - 7 | 91-140 415-05 | 3 - 9 |
| 91-084 134-70/789 | 11 - 1 | 91-118 196-12 | 3 - 2 | 91-140 127-05 | 3 - 7 | 91-140 416-05 | 3 - 10, 3 - 11 |

| No. | Seite Page Pages Página | No. | Seite Page Pages Página | No. | Seite Page Pages Página | No. | Seite Page Pages Página |
|-------------------|----------------------------------|-------------------|----------------------------------|-------------------|----------------------------------|-------------------|----------------------------------|
| 91-140 417-05 | 4 - 3, 4 - 4 | 91-140 567-05 | 3 - 4 | 91-141 443-15 | 3 - 5 | 91-141 564-71/951 | 3 - 11 |
| 91-140 418-05 | 3 - 10, 3 - 11 | 91-140 568-91 | 3 - 4 | 91-141 452-12 | 3 - 6 | 91-141 565-71/951 | 3 - 10 |
| 91-140 419-05 | 4 - 3, 4 - 4 | 91-140 569-05 | 3 - 4 | 91-141 454-91 | 3 - 6 | 91-141 566-71/951 | 3 - 11 |
| 91-140 451-91 | 4 - 2 | 91-140 573-91 | 3 - 4 | 91-141 481-01 | 3 - 6 | 91-141 567-71/951 | 3 - 10 |
| 91-140 453-05 | 3 - 9, 4 - 2 | 91-140 574-05 | 3 - 4 | 91-141 520-75/951 | 3 - 10 | 91-141 568-71/951 | 4 - 4 |
| 91-140 454-91 | 3 - 9 | 91-140 575-91 | 3 - 4 | 91-141 521-75/951 | 3 - 11 | 91-141 569-71/951 | 4 - 3 |
| 91-140 456-05 | 3 - 9, 4 - 2 | 91-140 648-01 | 4 - 2 | 91-141 522-01 | 3 - 10, 3 - 11 | 91-141 570-71/951 | 4 - 4 |
| 91-140 510-91 | 4 - 5 | 91-140 650-91 | 4 - 2 | 91-141 525-01 | 3 - 10, 3 - 11 | 91-141 571-71/951 | 4 - 3 |
| 91-140 511-91 | 4 - 5 | 91-140 651-05 | 4 - 2 | 91-141 527-01 | 4 - 3, 4 - 4 | 91-141 572-12 | 3 - 12 |
| 91-140 512-91 | 4 - 5 | 91-140 695-91 | 4 - 5 | 91-141 529-01 | 4 - 3, 4 - 4 | 91-141 573-75/951 | 3 - 12 |
| 91-140 513-91 | 4 - 5 | 91-140 698-91 | 4 - 5 | 91-141 531-75/951 | 4 - 3 | 91-141 575-75/951 | 3 - 2 |
| 91-140 516-75/770 | 3 - 6, 3 - 10, 3 - 11 | 91-140 710-91 | 3 - 14 | 91-141 532-75/951 | 4 - 4 | 91-141 576-71/951 | 3 - 2 |
| 91-140 532-05 | 3 - 4 | 91-140 711-15 | 3 - 14 | 91-141 533-75/951 | 4 - 3 | 91-141 612-91 | 3 - 7 |
| 91-140 533-05 | 3 - 4 | 91-140 712-11 | 3 - 14, 4 - 6 | 91-141 534-75/951 | 4 - 4 | 91-141 617-75/698 | 3 - 1 |
| 91-140 534-01 | 3 - 4 | 91-140 715-05 | 3 - 14, 4 - 6 | 91-141 535-05 | 3 - 10, 3 - 11, 4 - 3, 4 - 4 | 91-141 618-75/895 | 3 - 1 |
| 91-140 538-91 | 3 - 9 | 91-140 720-15 | 3 - 14 | 91-141 536-90 | 3 - 10, 3 - 11, 4 - 3, 4 - 4 | 91-141 620-75/893 | 3 - 7 |
| 91-140 539-91 | 3 - 9 | 91-140 726-01 | 4 - 3, 4 - 4 | 91-141 540-15 | 3 - 10, 3 - 11, 4 - 3, 4 - 4 | 91-141 621-75/895 | 3 - 1 |
| 91-140 540-91 | 4 - 2 | 91-140 728-92 | 4 - 3, 4 - 4 | 91-141 541-05 | 3 - 10, 3 - 11 | 91-141 622-75/698 | 3 - 1 |
| 91-140 543-91 | 3 - 9 | 91-140 731-90 | 4 - 3, 4 - 4 | 91-141 542-05 | 3 - 10, 3 - 11, 4 - 3, 4 - 4 | 91-141 623-75/698 | 3 - 1 |
| 91-140 544-91 | 4 - 2 | 91-140 945-05 | 3 - 9, 4 - 2 | 91-141 543-05 | 4 - 3, 4 - 4 | 91-141 624-75/895 | 3 - 1 |
| 91-140 545-91 | 4 - 2 | 91-140 987-05 | 4 - 4 | 91-141 545-05 | 3 - 10, 3 - 11, 4 - 3, 4 - 4 | 91-141 626-05 | 3 - 3 |
| 91-140 550-91 | 3 - 9, 4 - 2 | 91-141 079-05 | 3 - 13 | 91-141 546-05 | 3 - 10, 3 - 11, 4 - 3, 4 - 4 | 91-141 628-75/895 | 3 - 1 |
| 91-140 551-91 | 3 - 9, 4 - 2 | 91-141 087-05 | 3 - 13 | 91-141 547-05 | 3 - 10, 3 - 11, 4 - 3, 4 - 4 | 91-141 633-15 | 4 - 1 |
| 91-140 552-91 | 3 - 9, 4 - 2 | 91-141 259-05 | 3 - 12 | 91-141 548-71/951 | 3 - 11 | 91-141 636-15 | 4 - 1 |
| 91-140 553-91 | 3 - 9, 4 - 2 | 91-141 307-05 | 3 - 2 | 91-141 549-71/951 | 3 - 10 | 91-141 640-75/893 | 11 - 1 |
| 91-140 560-90 | 3 - 13 | 91-141 327-71/951 | 3 - 2 | 91-141 550-71/951 | 3 - 11 | 91-141 641-92 | 3 - 3 |
| 91-140 561-91 | 3 - 13 | 91-141 328-75/951 | 3 - 2 | 91-141 551-71/951 | 3 - 10 | 91-141 658-15 | 4 - 6 |
| 91-140 562-05 | 3 - 13 | 91-141 426-15 | 3 - 1 | 91-141 552-71/951 | 4 - 4 | 91-141 659-15 | 4 - 6 |
| 91-140 563-05 | 3 - 13 | 91-141 427-15 | 3 - 1 | 91-141 553-71/951 | 4 - 3 | 91-141 660-11 | 3 - 3 |
| 91-140 564-92 | 3 - 13 | 91-141 428-15 | 3 - 1 | 91-141 554-71/951 | 4 - 4 | 91-141 662-15 | 3 - 3 |
| 91-140 565-91 | 3 - 4 | 91-141 441-15 | 3 - 14, 4 - 6 | 91-141 555-71/951 | 4 - 3 | 91-141 663-15 | 3 - 3 |
| 91-140 566-05 | 3 - 4 | 91-141 442-15 | 3 - 5 | 91-141 563-01 | 3 - 10, 3 - 11, 4 - 3, 4 - 4 | 91-141 664-75/895 | 3 - 1 |

| No. | Seite Page Pages Página | No. | Seite Page Pages Página | No. | Seite Page Pages Página | No. | Seite Page Pages Página |
|-------------------|----------------------------------|-------------------|----------------------------------|-------------------|----------------------------------|---------------|----------------------------------|
| 91-141 665-91 | 3 - 2 | 91-168 909-15 | 4 - 7 | 91-229 081-15 | 8 - 1 | 99-136 072-95 | 6 - 1 |
| 91-141 666-05 | 3 - 2 | 91-168 910-05 | 4 - 7 | 91-229 082-15 | 8 - 1 | 99-136 546-91 | 7 - 1 |
| 91-141 667-05 | 3 - 2 | 91-168 934-05 | 4 - 7 | 91-266 114-15 | 3 - 1 | 99-136 849-55 | 3 - 1 |
| 91-141 668-15 | 3 - 2 | 91-168 934-92 | 4 - 7 | 91-266 397-01 | 3 - 6 | 99-137 001-05 | 3 - 1 |
| 91-141 669-15 | 3 - 5 | 91-171 042-05 | 3 - 6 | 91-700 082-15 | 3 - 5 | 99-137 151-45 | 3 - 6 |
| 91-141 671-91 | 4 - 6 | 91-171 049-05 | 3 - 6 | 91-700 364-25 | 3 - 1 | 99-137 227-91 | 5 - 1 |
| 91-141 674-05 | 3 - 8 | 91-174 062-15 | 4 - 1 | 91-700 412-25 | 3 - 1, 3 - 5 | 99-137 228-91 | 6 - 1 |
| 91-141 676-15 | 3 - 1 | 91-174 783-05 | 3 - 6 | 91-700 510-15 | 4 - 7 | | |
| 91-141 679-71/698 | 3 - 8 | 91-174 879-05 | 3 - 7 | 91-700 592-15 | 3 - 3 | | |
| 91-141 688-90 | 3 - 1 | 91-175 023-05 | 3 - 13 | 91-700 687-15 | 6 - 2 | | |
| 91-141 711-91 | 3 - 6 | 91-175 126-05 | 3 - 13 | 91-700 689-15 | 3 - 6, 3 - 12, 3 - 13 | | |
| 91-141 714-91 | 3 - 6 | 91-175 171-05 | 4 - 1 | 91-700 785-15 | 3 - 10, 3 - 11, 3 - 13, 4 - 7 | | |
| 91-141 719-71/895 | 3 - 1 | 91-176 327-05 | 4 - 1 | 91-700 961-15 | 3 - 8, 6 - 2 | | |
| 91-141 721-25 | 3 - 2 | 91-176 328-05 | 4 - 1 | 91-709 610-71/698 | 3 - 8 | | |
| 91-141 722-15 | 3 - 3 | 91-176 329-05 | 4 - 1 | 95-215 000-04/261 | 5 - 1, 6 - 1 | | |
| 91-164 056-05 | 3 - 3 | 91-176 332-25 | 3 - 5 | 95-215 000-04/288 | 6 - 1 | | |
| 91-166 452-21 | 3 - 7 | 91-187 293-75/893 | 7 - 1 | 95-215 040-15/927 | 6 - 1 | | |
| 91-166 559-25 | 3 - 5 | 91-187 386-75/893 | 7 - 1 | 95-215 040-15/928 | 6 - 1 | | |
| 91-166 670-15 | 3 - 1 | 91-187 426-70/893 | 7 - 1 | 95-215 040-15/930 | 5 - 1 | | |
| 91-167 553-11 | 4 - 7 | 91-229 068-75/895 | 8 - 1 | 95-215 040-16/153 | 6 - 1 | | |
| 91-167 559-05 | 4 - 7 | 91-229 069-75/895 | 8 - 1 | 95-215 040-16/155 | 6 - 1 | | |
| 91-167 560-05 | 4 - 7 | 91-229 070-70/895 | 8 - 1 | 95-215 040-16/156 | 5 - 1, 6 - 1 | | |
| 91-167 636-05 | 4 - 7 | 91-229 071-71/895 | 8 - 1 | 95-215 040-16/160 | 6 - 1 | | |
| 91-168 025-05 | 3 - 4 | 91-229 072-45 | 8 - 1 | 95-215 040-16/181 | 5 - 1 | | |
| 91-168 319-12 | 3 - 10, 3 - 11, 3 - 13, 4 - 7 | 91-229 073-71/895 | 8 - 1 | 95-215 040-16/183 | 5 - 1 | | |
| 91-168 331-05 | 3 - 14, 4 - 6 | 91-229 074-05 | 8 - 1 | 95-215 080-09/903 | 6 - 1 | | |
| 91-168 375-70/893 | 3 - 14 | 91-229 075-45 | 8 - 1 | 95-215 080-09/905 | 5 - 1, 6 - 1 | | |
| 91-168 376-15 | 3 - 14 | 91-229 076-75/698 | 8 - 1 | 95-665 735-91 | 13 - 1 | | |
| 91-168 415-15 | 4 - 7 | 91-229 077-72/895 | 8 - 1 | 99-134 089-05 | 11 - 1 | | |
| 91-168 480-15 | 3 - 7 | 91-229 078-25 | 8 - 1 | 99-134 093-05 | 11 - 1 | | |
| 91-168 906-02 | 4 - 7 | 91-229 079-15 | 8 - 1 | 99-135 188-85 | 6 - 2 | | |
| 91-168 907-05 | 4 - 7 | 91-229 080-15 | 8 - 1 | 99-135 617-95 | 6 - 1 | | |

242

Unterklassen-Ausstattung

Subclass parts

Composition des sous-classes

Composición de las subclases

| Unterklasse Subclass Sous-classe Subclase | -6/01 | -6/01-900/56 | -6/07 |
|--|--|--|---|
| Arbeitsgang Operation Opération Operación | Für allgemeine Näharbeiten. Standardform des Teilesatzes. For ordinary sewing operations. Standard part set. Travaux d'utilité courante. Jeu de pièces standard. Para trabajos de costura en general. Juego de piezas estándar. | Für allgemeine Näharbeiten. Standardform des Teilesatzes. For ordinary sewing operations. Standard part set. Travaux d'utilité courante. Jeu de pièces standard. Para trabajos de costura en general. Juego de piezas estándar. | Wie -6/01, jedoch mit verkleinerter Teilesatzform. Same as -6/01, but with small-size parts set. Comme la -6/01, mais avec jeu de pièces de dimensions réduites. Como la -6/01, pero con juego de piezas reducido. |
| Ausführung Model Version Tipo de máquina | BN | BN | A |
| Nadelabstand in mm Needle gauge in mm Ecartement des aiguilles en mm Distancia entre agujas en mm | 4,8; 6,4; 8,0; 10,0 | 4,8; 6,4; 8,0; 10,0 | 3,2; 4,8 |
| Teilesatz vollst. Part set assy. Jeu de pièces complète Juego de piezas compl. | 91-202 150-93/001 f̄0 = 4,8 mm 91-202 150-93/002 f̄0 = 6,4 mm 91-202 150-93/003 f̄0 = 8,0 mm 91-202 150-93/004 f̄0 = 10,0 mm | 91-202 151-93/001 f̄0 = 4,8 mm 91-202 151-93/002 f̄0 = 6,4 mm 91-202 151-93/003 f̄0 = 8,0 mm 91-202 151-93/004 f̄0 = 10,0 mm | 91-202 152-93/001 f̄0 = 3,2 mm 91-202 152-93/002 f̄0 = 4,8 mm |
| Nadelhalter f̄0/2)* Needle holder Pince-aiguille Portaagujas | 91-710 004-93/006 f̄0 = 4,8 mm 91-710 004-93/009 f̄0 = 6,4 mm 91-710 004-93/011 f̄0 = 8,0 mm 91-710 004-93/014 f̄0 = 10,0 mm | 91-710 004-93/006 f̄0 = 4,8 mm 91-710 004-93/009 f̄0 = 6,4 mm 91-710 004-93/011 f̄0 = 8,0 mm 91-710 004-93/014 f̄0 = 10,0 mm | 91-710 004-93/003 f̄0 = 3,2 mm 91-710 004-93/006 f̄0 = 4,8 mm |
| Nähfuß 4) f̄0/2)* Presser foot Pied presseur Pie prensatelas | 91-040 811-03/036 f̄0 = 4,8 mm 91-040 811-03/040 f̄0 = 6,4 mm 91-040 811-03/044 f̄0 = 8,0 mm 91-040 811-03/049 f̄0 = 10,0 mm | 91-040 811-03/036 f̄0 = 4,8 mm 91-040 811-03/040 f̄0 = 6,4 mm 91-040 811-03/044 f̄0 = 8,0 mm 91-040 811-03/049 f̄0 = 10,0 mm | 91-026 805-03/005 f̄0 = 3,2 mm 91-710 811-03/010 f̄0 = 4,8 mm |
| Stichplatte 4) f̄0/2)* Needle plate Plaque à aiguille Placa de aguja | 91-046 735-04/011 f̄0 = 4,8 mm 91-046 715-04/101 f̄0 = 6,4 mm 91-046 715-04/102 f̄0 = 8,0 mm 91-046 715-04/017 f̄0 = 10,0 mm | 91-058 871-04/012 f̄0 = 4,8 mm 91-058 871-04/015 f̄0 = 6,4 mm 91-058 871-04/017 f̄0 = 8,0 mm 91-058 871-04/019 f̄0 = 10,0 mm | 91-045 493-04/009 f̄0 = 3,2 mm 91-045 493-04/004 f̄0 = 4,8 mm |
| Stoffschieber 4) f̄0/2)* Feed dog Griffe Transportador inferior | 91-046 734-04/008 f̄0 = 4,8 mm 91-046 714-04/062 f̄0 = 6,4 mm 91-046 714-04/066 f̄0 = 8,0 mm 91-046 714-04/071 f̄0 = 10,0 mm | 91-046 734-04/008 f̄0 = 4,8 mm 91-046 714-04/062 f̄0 = 6,4 mm 91-046 714-04/066 f̄0 = 8,0 mm 91-046 714-04/071 f̄0 = 10,0 mm | 91-045 492-04/021 f̄0 = 3,2 mm 91-045 492-04/003 f̄0 = 4,8 mm |
| Schieber, links f̄0/2)* Slide, left Glissière, gauche Corredera, izquierda | 91-018 889-24/060 f̄0 = 4,8 mm f̄0 = 6,4 mm f̄0 = 8,0 mm f̄0 = 10,0 mm | 91-018 889-24/060 f̄0 = 4,8 mm f̄0 = 6,4 mm f̄0 = 8,0 mm f̄0 = 10,0 mm | 91-018 889-24/060 f̄0 = 3,2 mm f̄0 = 4,8 mm |
| Schieber, rechts f̄0/2)* Slide, right Glissière, droite Corredera, derecha | 91-010 061-24/060 f̄0 = 4,8 mm f̄0 = 6,4 mm f̄0 = 8,0 mm f̄0 = 10,0 mm | 91-018 888-24/030 f̄0 = 4,8 mm f̄0 = 6,4 mm f̄0 = 8,0 mm f̄0 = 10,0 mm | 91-010 061-24/060 f̄0 = 3,2 mm f̄0 = 4,8 mm |
| | * In Teilesatz vollständig enthalten Included in full in the part set Contenu intégralement dans le jeu de pièces Incluido por completo en el juego de piezas | | |



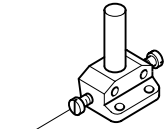
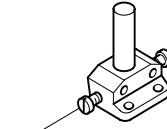
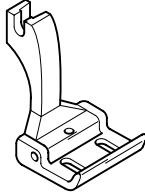
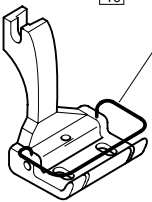
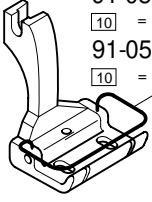
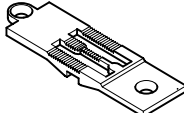
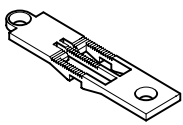
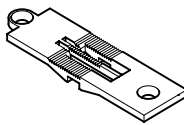
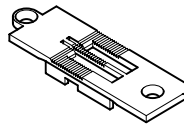
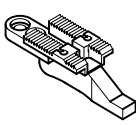
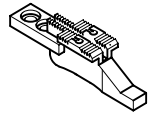
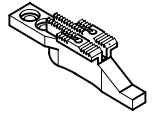
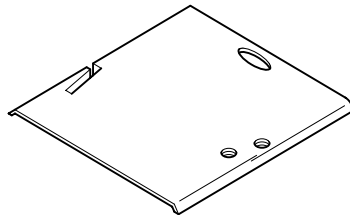



| | | | |
|--|--|---|---|
| <p>91-710 004-93/003 4 10 = 3,2 mm</p> <p>91-710 004-93/006 4 10 = 4,8 mm</p>  <p>91-173 664-15 (2x)</p> | <p>91-710 004-93/006 4 10 = 4,8 mm</p> <p>91-710 004-93/009 4 10 = 6,4 mm</p> <p>91-710 004-93/011 4 10 = 8,0 mm</p> <p>91-710 004-93/014 4 10 = 10,0 mm</p>  <p>91-173 664-15 (2x)</p> | <p>91-026 805-03/005 4 10 = 3,2 mm</p>  | |
| <p>-6/07</p> | | <p>-6/01 -6/01-900/ 56</p> | <p>-6/07</p> |
| <p>91-040 811-03/010 4 10 = 4,8 mm</p>  <p>91-057 081-04/001 3/1 10 = 4,8 mm</p> | <p>91-040 811-03/036 4 10 = 4,8 mm</p> <p>91-040 811-03/040 4 10 = 6,4 mm</p> <p>91-040 811-03/044 4 10 = 8,0 mm</p> <p>91-040 811-03/049 4 10 = 10,0 mm</p>  <p>91-057 081-04/001 3/1 10 = 4,8; 6,4 mm</p> <p>91-057 081-04/001 3/1 10 = 8; 10 mm</p> | <p>91-045 493-04/004 4 10 = 4,8 mm</p> <p>91-045 493-04/009 4 10 = 3,2 mm</p>  | |
| <p>-6/07</p> | | <p>-6/01 -6/01-900/ 56</p> | <p>-6/07</p> |
| <p>91-046 715-04/101 4 10 = 6,4 mm</p> <p>91-046 715-04/102 4 10 = 8,0 mm</p> <p>91-046 715-04/017 4 10 = 10,0 mm</p>  | <p>91-046 735-04/001 4 10 = 4,8 mm</p>  | <p>91-058 871-04/012 4 10 = 4,8 mm</p> <p>91-058 871-04/015 4 10 = 6,4 mm</p> <p>91-058 871-04/017 4 10 = 8,0 mm</p> <p>91-058 871-04/019 4 10 = 10,0 mm</p>  | <p>91-045 492-04/003 4 10 = 4,8 mm</p> <p>91-045 492-04/021 4 10 = 3,2 mm</p>  |
| <p>-6/01</p> | <p>-6/01</p> | <p>-6/01-900/ 56</p> | <p>-6/07</p> |
| <p>91-046 714-04/062 4 10 = 6,4 mm</p> <p>91-046 714-04/066 4 10 = 8,0 mm</p> <p>91-046 714-04/071 4 10 = 10,0 mm</p>  | <p>91-046 734-04/008 4 10 = 4,8 mm</p>  | <p>91-010 061-24/060</p> <p>10 = 3,2 mm</p> <p>10 = 4,8 mm</p> <p>10 = 6,4 mm</p> <p>10 = 8,0 mm</p> <p>10 = 10,0 mm</p>  | |
| <p>-6/01 -6/01-900/ 56</p> | <p>-6/01 -6/01-900/ 56</p> | <p>-6/01 -6/07</p> | |

15.02

Nähwerkzeuge
Gauge parts
Organes de couture
Organos de costura PFAFF 242



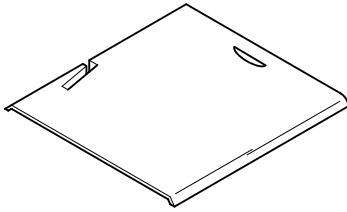

91-018 888-24/030

-  = 4,8 mm
-  = 6,4 mm
-  = 8,0 mm
-  = 10,0 mm



-6/01-900/56

91-018 889-24/060

-  = 3,2 mm (-6/07)
-  = 4,8 mm
-  = 6,4 mm
-  = 8,0 mm
-  = 10,0 mm

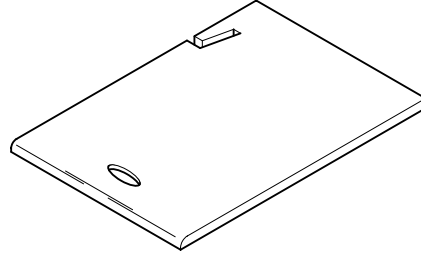

-6/01
-6/01-900/56
-6/07

PFAFF

1242

Unterklassen-Ausstattung

Subclass parts

Composition des sous-classes

Composición de las subclases

| Unterklasse Subclass Sous-classe Subclase | -6/01 | -6/01-900/56 | -6/01 | -6/01-900/56 |
|--|--|--|--|--|
| Arbeitsgang Operation Opération Operación | Für allgemeine Näharbeiten. Standardform des Teilesatzes. For ordinary sewing operations. Standard part set. Travaux d'utilité courante. Jeu de pièces standard. Para trabajos de costura en general. Juego de piezas estándar. | Für allgemeine Näharbeiten. Standardform des Teilesatzes. For ordinary sewing operations. Standard part set. Travaux d'utilité courante. Jeu de pièces standard. Para trabajos de costura en general. Juego de piezas estándar. | Für allgemeine Näharbeiten. Standardform des Teilesatzes. For ordinary sewing operations. Standard part set. Travaux d'utilité courante. Jeu de pièces standard. Para trabajos de costura en general. Juego de piezas estándar. | Für allgemeine Näharbeiten. Standardform des Teilesatzes. For ordinary sewing operations. Standard part set. Travaux d'utilité courante. Jeu de pièces standard. Para trabajos de costura en general. Juego de piezas estándar. |
| Ausführung Model Version Tipo de máquina | BN | BN | CN | CN |
| Nadelabstand in mm Needle gauge in mm Ecartement des aiguilles en mm Distancia entre agujas en mm | 4,8; 6,4 | 4,8; 6,4 | 6,4; 8,0; 10,0; 12,0 | 6,4; 8,0; 10,0; 12,0 |
| Teilesatz vollst. Part set assy. Jeu de pièces complète Juego de piezas compl. | 91-202 150-93/001 f10= 4,8 mm 91-202 150-93/002 f10= 6,4 mm | 91-202 151-93/001 f10= 4,8 mm 91-202 151-93/002 f10= 6,4 mm | 91-202 117-93/001 f10= 6,4 mm 91-202 194-93/001 f10= 8,0 mm 91-202 194-93/002 f10= 10,0 mm 91-202 194-93/003 f10= 12,0 mm | 91-202 119-93/001 f10= 6,4 mm 91-202 194-93/004 f10= 8,0 mm 91-202 194-93/008 f10= 10,0 mm 91-202 194-93/006 f10= 12,0 mm |
| Nadelhalter f10/2* Needle holder Pince-aiguille Portaagujas | 91-710 004-93/006 f10= 4,8 mm 91-710 004-93/009 f10= 6,4 mm | 91-710 004-93/006 f10= 4,8 mm 91-710 004-93/009 f10= 6,4 mm | 91-710 004-93/009 f10= 6,4 mm 91-710 004-93/011 f10= 8,0 mm 91-710 004-93/014 f10= 10,0 mm 91-710 004-93/016 f10= 12,0 mm | 91-710 004-93/009 f10= 6,4 mm 91-710 004-93/011 f10= 8,0 mm 91-710 004-93/014 f10= 10,0 mm 91-710 004-93/016 f10= 12,0 mm |
| Nähfuß 4 f10/2* Presser foot Pied presseur Pie prensatelas | 91-040 811-03/036 f10= 4,8 mm 91-040 811-03/040 f10= 6,4 mm | 91-040 811-03/036 f10= 4,8 mm 91-040 811-03/040 f10= 6,4 mm | 91-040 811-03/129 f10= 6,4 mm 91-040 811-03/131 f10= 8,0 mm 91-040 811-03/133 f10= 10,0 mm 91-040 811-03/135 f10= 12,0 mm | 91-040 811-03/129 f10= 6,4 mm 91-040 811-03/131 f10= 8,0 mm 91-040 811-03/133 f10= 10,0 mm 91-040 811-03/135 f10= 12,0 mm |
| Stichplatte 4 f10/2* Needle plate Plaque à aiguille Placa de aguja | 91-046 735-04/001 f10= 4,8 mm 91-046 715-04/101 f10= 6,4 mm | 91-058 871-04/012 f10= 4,8 mm 91-058 871-04/015 f10= 6,4 mm | 91-046 715-04/104 f10= 6,4 mm 91-046 715-04/105 f10= 8,0 mm 91-046 715-04/064 f10= 10,0 mm 91-046 715-04/066 f10= 12,0 mm | 91-058 867-04/006 f10= 6,4 mm 91-058 867-04/008 f10= 8,0 mm 91-058 867-04/064 f10= 10,0 mm 91-058 867-04/012 f10= 12,0 mm |
| Stoffschieber 4 f10/2* Feed dog Griffe Transportador inferior | 91-046 734-04/008 f10= 4,8 mm 91-046 714-04/062 f10= 6,4 mm | 91-046 734-04/008 f10= 4,8 mm 91-046 714-04/062 f10= 6,4 mm | 91-046 714-04/130 f10= 6,4 mm 91-046 714-04/133 f10= 8,0 mm 91-046 714-04/135 f10= 10,0 mm 91-046 714-04/137 f10= 12,0 mm | 91-047 151-04/008 f10= 6,4 mm 91-047 151-04/017 f10= 8,0 mm 91-047 151-04/018 f10= 10,0 mm 91-047 151-04/019 f10= 12,0 mm |
| Schieber, links f10/2 Slide, left Glissière, gauche Corredera, izquierda | 91-018 889-24/060 f10= 4,8 mm f10= 6,4 mm | 91-018 889-24/060 f10= 4,8 mm f10= 6,4 mm | 91-018 889-24/060 f10= 6,4 mm f10= 8,0 mm f10= 10,0 mm f10= 12,0 mm | 91-018 889-24/060 f10= 6,4 mm f10= 8,0 mm f10= 10,0 mm f10= 12,0 mm |
| Schieber, rechts f10/2 Slide, right Glissière, droite Corredera, derecha | 91-010 061-24/060 f10= 4,8 mm f10= 6,4 mm | 91-018 888-24/030 f10= 4,8 mm f10= 6,4 mm | 91-010 061-24/060 f10= 6,4 mm f10= 8,0 mm f10= 10,0 mm f10= 12,0 mm | 91-018 888-24/030 f10= 6,4 mm f10= 8,0 mm f10= 10,0 mm f10= 12,0 mm |
| | * In Teilesatz vollständig enthalten Included in full in the part set Contenu intégralement dans le jeu de pièces Incluido por completo en el juego de piezas | | | |



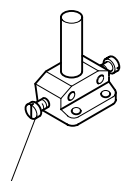
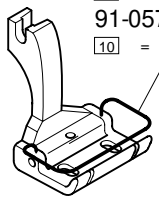



| | | | |
|--|---|---|--|
| <p>91-710 004-93/006 10 = 4,8 mm</p> <p>91-710 004-93/009 10 = 6,4 mm</p> <p>91-710 004-93/011 10 = 8,0 mm</p> <p>91-710 004-93/014 10 = 10,0 mm</p> <p>91-710 004-93/016 10 = 12,0 mm</p> |  91-173 664-15 (2x) | <p>91-040 811-03/036 B 10 = 4,8 mm</p> <p>91-040 811-03/040 B 10 = 6,4 mm</p> <p>91-040 811-03/129 C 10 = 6,4 mm</p> <p>91-040 811-03/131 C 10 = 8,0 mm</p> <p>91-040 811-03/133 C 10 = 10,0 mm</p> <p>91-040 811-03/135 C 10 = 12,0 mm</p> | <p>91-057 081-04/001 3/1 10 = 4,8; 6,4 mm</p> <p>91-057 081-04/001 3/1 10 = 8; 12 mm</p>  |
| -6/01 -6/01-900/56 | | -6/01 -6/01-900/56 | |
| <p>91-046 715-04/101 B 10 = 6,4 mm</p> <p>91-046 715-04/104 C 10 = 6,4 mm</p> <p>91-046 715-04/105 C 10 = 8,0 mm</p> <p>91-046 715-04/064 C 10 = 10,0 mm</p> | <p>91-046 715-04/066 C 10 = 12,0 mm</p> | <p>91-046 735-04/001 B 10 = 4,8 mm</p> | <p>91-058 867-04/006 C 10 = 6,4 mm</p> <p>91-058 867-04/008 C 10 = 8,0 mm</p> <p>91-058 867-04/010 C 10 = 10,0 mm</p> |
| -6/01 | | -6/01 | |
| -6/01-900/56 | | -6/01-900/56 | |
| <p>91-058 867-04/012 4 10 = 12,0 mm</p> | <p>91-058 871-04/012 B 10 = 4,8 mm</p> <p>91-058 871-04/015 B 10 = 6,4 mm</p> | <p>91-046 714-04/062 B 10 = 6,4 mm</p> | <p>91-046 714-04/130 C 10 = 6,4 mm</p> <p>91-046 714-04/133 C 10 = 8,0 mm</p> <p>91-046 714-04/135 C 10 = 10,0 mm</p> |
| -6/01-900/56 | | -6/01-900/56 | |
| -6/01-900/56 | | -6/01-900/56 | |
| <p>91-046 714-04/137 C 10 = 12,0 mm</p> | <p>91-046 734-04/008 B 10 = 4,8 mm</p> | <p>91-047 151-04/008 C 10 = 6,4 mm</p> <p>91-047 151-04/017 C 10 = 8,0 mm</p> <p>91-047 151-04/018 C 10 = 10,0 mm</p> | <p>91-047 151-04/019 C 10 = 12,0 mm</p> |
| -6/01 | | -6/01 | |
| -6/01-900/56 | | -6/01-900/56 | |
| -6/01-900/56 | | -6/01-900/56 | |

15.04

Nähwerkzeuge
Gauge parts
Organes de couture
Organos de costura PFAFF 1242



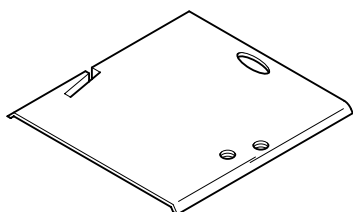

91-010 061-24/060

-  = 4,8 mm
-  = 6,4 mm
-  = 8,0 mm
-  = 10,0 mm
-  = 12,0 mm



-6/01



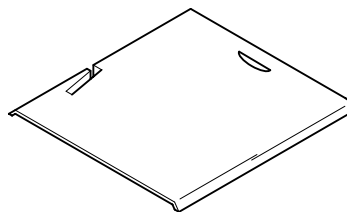

91-018 888-24/030

-  = 4,8 mm
-  = 6,4 mm
-  = 8,0 mm
-  = 10,0 mm
-  = 12,0 mm



-6/01-900/56

91-018 889-24/060

-  = 4,8 mm
-  = 6,4 mm
-  = 8,0 mm
-  = 10,0 mm
-  = 12,0 mm

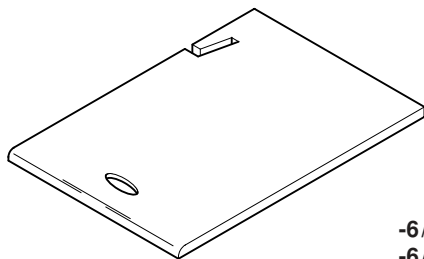

-6/01
-6/01-900/56

PFAFF