

Yamato[®]

INSTRUCTIONS & PARTS LIST

for

VF2502, 2502P

High Speed 3 Needle Double Chainstitch Machine

This Instructions list the different items
from the instructions for VF2400 Class.

No. 1

 **YAMATO SEWING MACHINE MFG. CO., LTD.**

CONTENTS

	Page
1. Specifications	1
2. Installation(Full-submerged type)	1
3. Drawing of Table Top Cut-out	2
4. Threading	4
5. Adjustment	5
5-1 Looper thread tension	5
5-2 Position of Looper Thread Take-up	5
5-3 Amount of Looper movement to the right	5
5-4 Height of Needle Bar	5
5-5 Front and rear position of Needle and Looper	6
5-6 Needle and Needle Guard	6
5-7 Adjustment of Upper Feed Roller(VF2502P)	6

***** ILLUSTRATED SPARE PARTS LIST *****



1. Specifications

Model	: VF2502-064, VF2502P-064
Description	: High Speed 3 Needle Double Chainstitch Machine (P : with Puller)
Dimensions	: 500(L) × 250(W) × 430(H)mm
Weight	: 41kg
Stitch type	: ISO(401·401·401)
Application	: lap seam for jeans and similar fabrics
Sewing speed	: Max. 5,000s.p.m.
Stitch length	: 1.4~3.6mm : stitch number 7~18 stitches/inch : 8~21 stitches/30mm
Needle to be used	: Schmetz or Organ UY128GAS
Needle distance	: 6.4mm(3.2, 3.2mm)
Needle stroke	: 31mm
Presser Foot lift	: 7.0mm
Feed regulation	: by Pushbutton
Differential ratio	: Max. normal differential 1:2 Max. reverse differential 1:0.7
Differential feed regulation	: Adjustable during operation by moving Lever up and down from outside
Lubrication	: Automatic lubrication by Oil Pump
Lubrication oil	: YAMATO SF OIL (Teresso 46 is also available.)
Capacity of oil reservoir	: 1,100cc
Installation	: Semi-submerged or full-submerged type

2. Installation(Full-submerged type)

☆ Installation of Supporting Board

Install Machine correctly as shown in the figure.
Set Screws to Supporting Board. Fix Supporting
Board on Machine Table. Place Rubber Cushions
on Screws and mount the Machine on them securely.

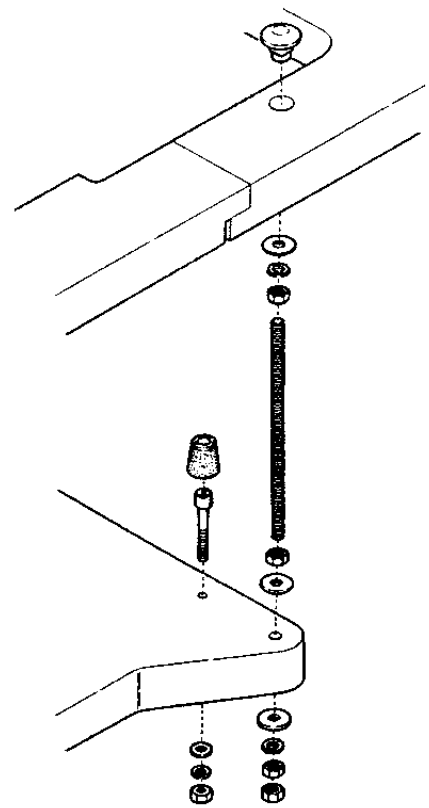
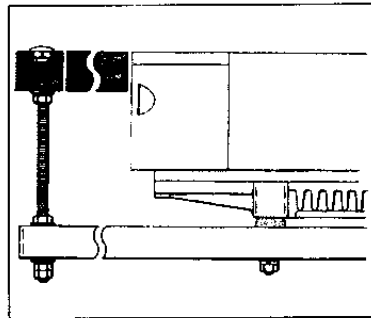

3. Drawing of Table Top Cut-out

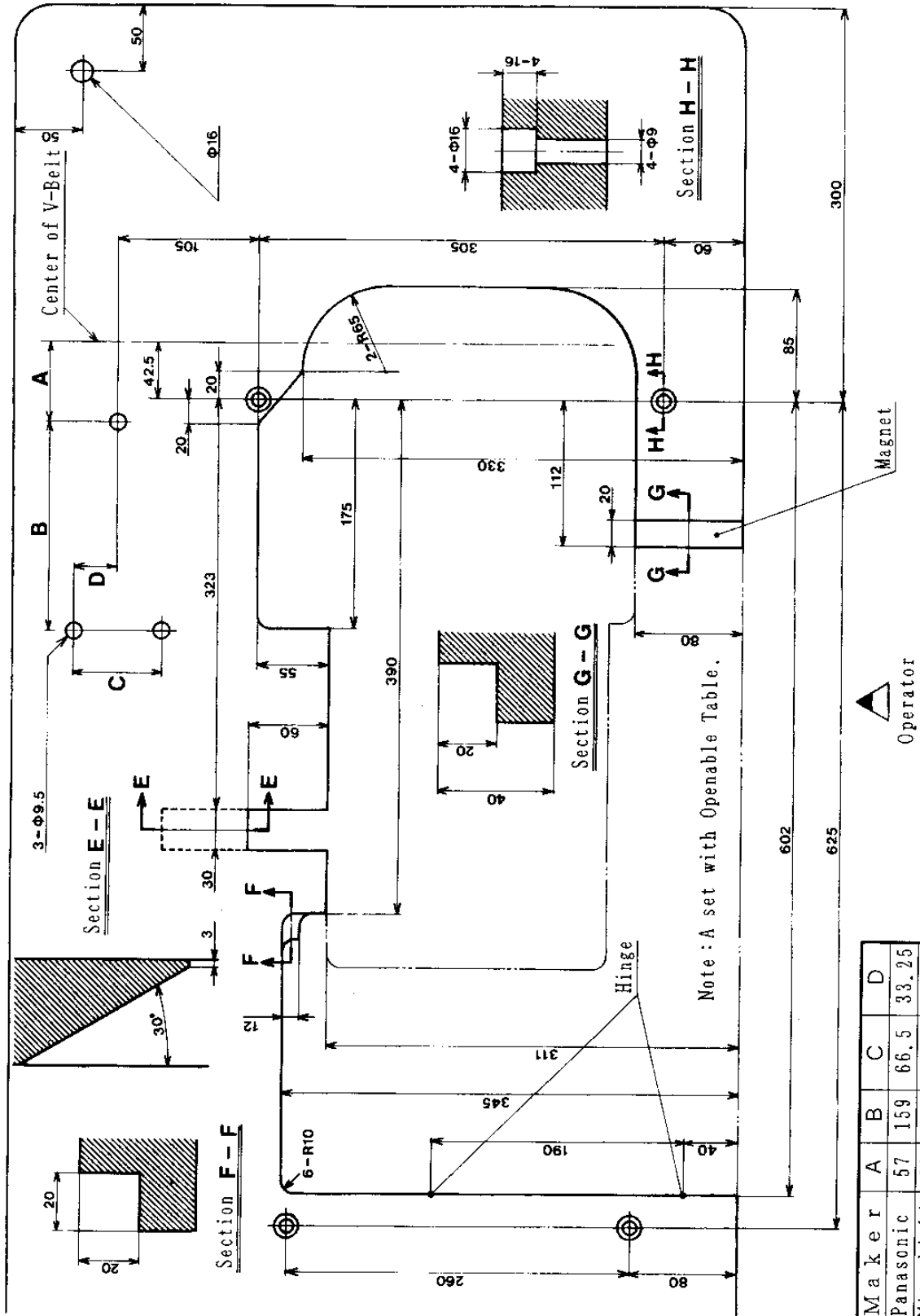

☆ Openable Table

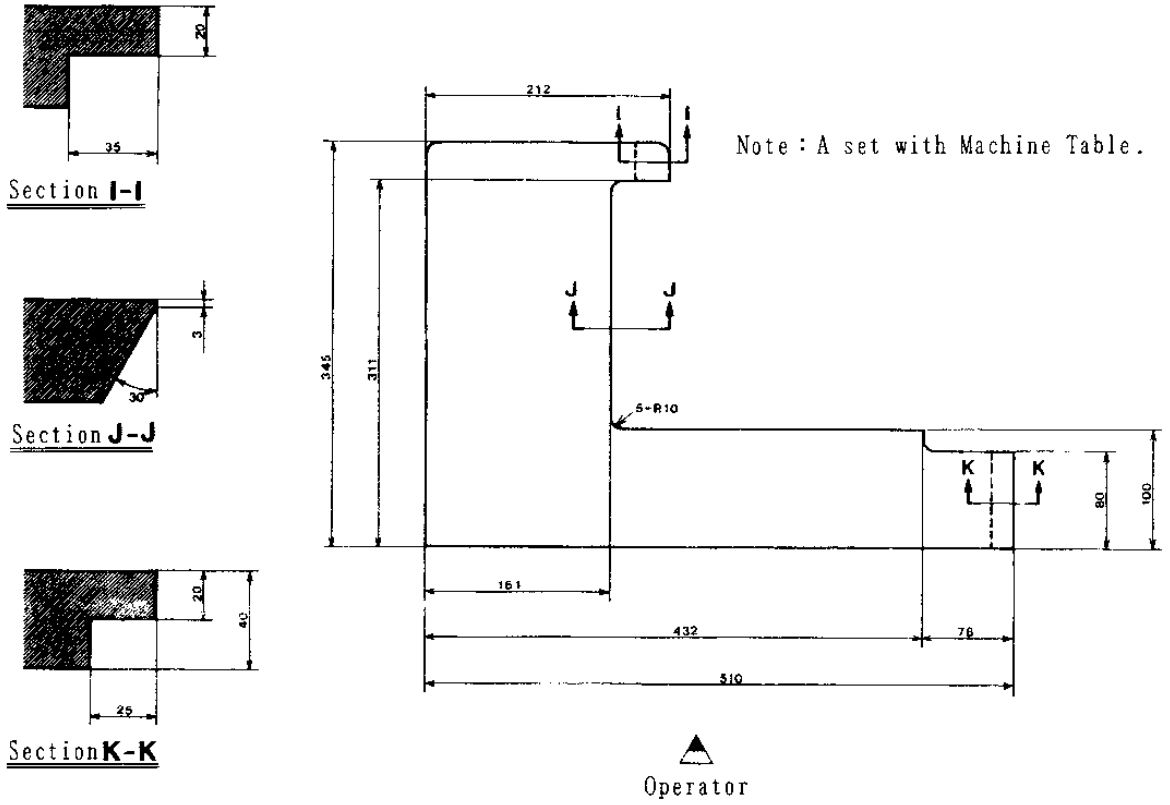

☆ Supporting Board

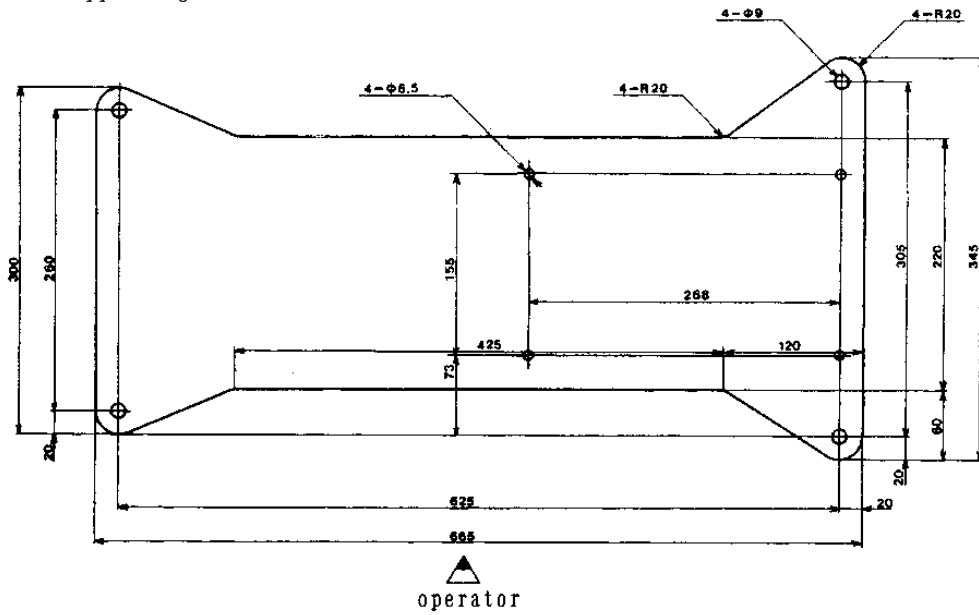

4. Threading

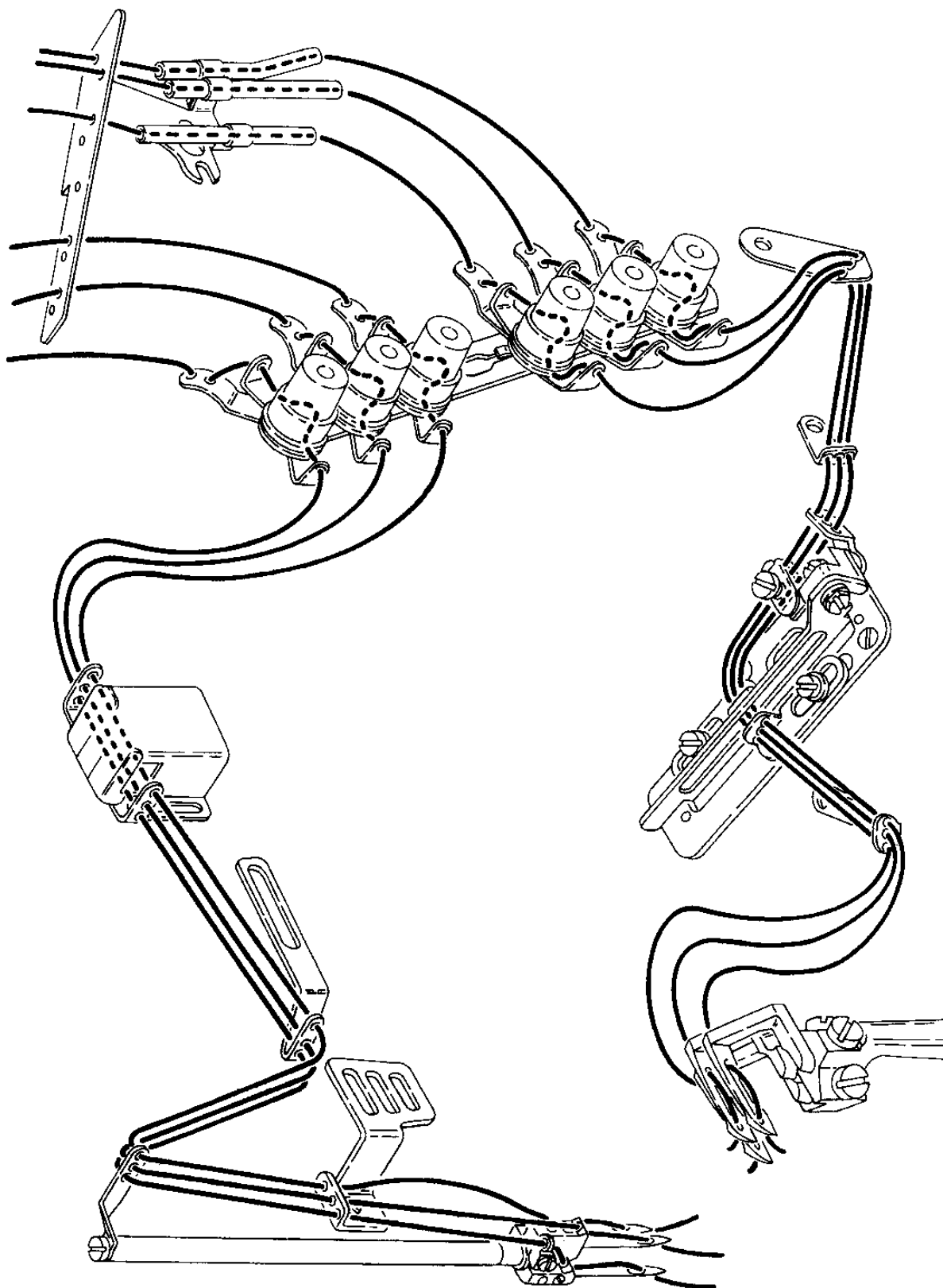

5. Adjustment

5-1 Loper thread tension

The figure shows Loper Thread Take-up.

Align the uppermost holes of Thread Take-up Eyelet (E) and (F) with the mark (·) of Cast-off Plate (D), which is standard.

To increase the feed amount of looper thread, loosen Screws (G) and (H) before sliding Eyelet (E) and (F) to (X)-direction.

To decrease it, loosen the Screws before sliding the Eyelets to (Y)-direction.

Take care that too much feed amount of looper thread may cause skip stitch.

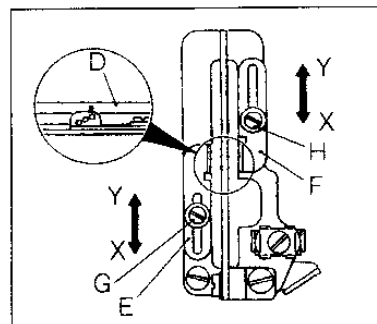

5-2 Position of Loper Thread Take-up

The figure shows Loper Thread Take-up seen from Needle Bar side. When Loper is at the leftmost position (the uppermost position of Needle Bar), loosen Screws (K) before making the flat face of Loper Thread Take-up (I) level with Supporting Plate (J).

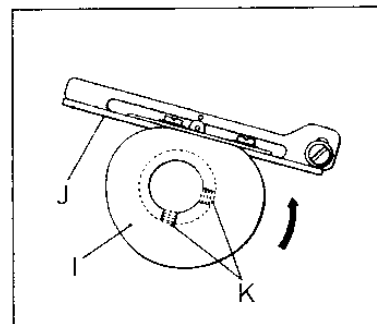

5-3 Amount of Loper movement to the right

We recommend the central Needle for the adjustment. When Needle is at the lowest position of its travel and Loper reaches the rightmost position, the distance between the tip of Loper and the center of Needle is 3.0~3.5mm respectively.

For its adjustment, loosen Screw (L) of Loper Holder.

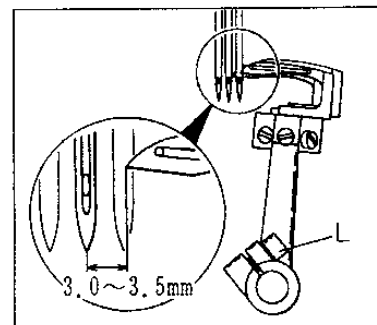

5-4 Height of Needle Bar

We recommend the central Needle for the adjustment.

At both moving to the left and to the right of Loper, when the tip of Loper comes to the center of Needle, the tip must pass 1.5~2.0mm above the upper end of needle eye. For its adjustment, insert Screwdriver from the hole (A) of Head Cover. Loosen Screw (B) of Needle Bar Bracket before moving Needle Bar up and down.

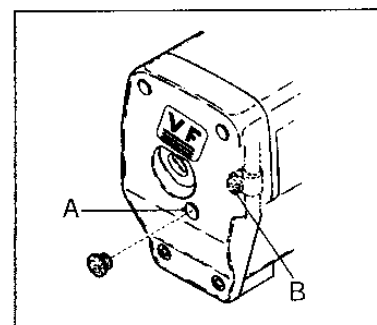
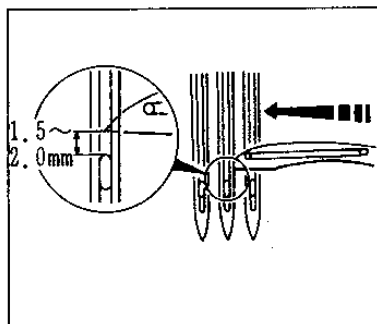

5-5 Front and rear position of Needle and Looper

The standard clearance between the tip of Loopers and Needles is 0~0.05mm respectively.

We recommend the central Needle(F) and Looper(C) for the first adjustment. Insert Looper(C) (with a flat spot) to the bottom before tightening Screw of Looper. For its adjustment, loosen Screw(L) of Looper Holder before moving Looper Holder in front and in rear. Next, for making the clearance of 0~0.05mm, loosen Screws of Looper(D) and (E) before turning Looper.

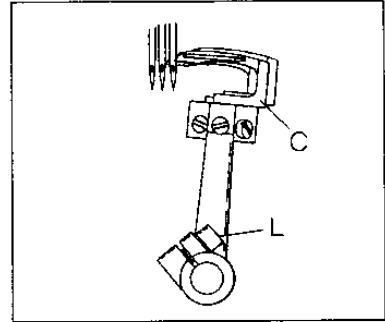
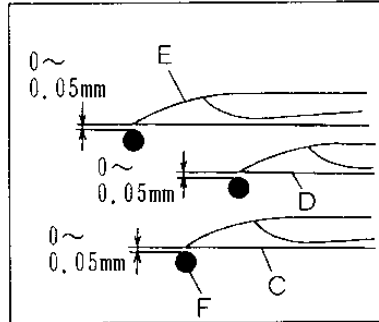

5-6 Needle and Needle Guard

We recommend the central Needle(F) and its Looper for the first adjustment.

When the Looper comes to the right end of Needle(F), the height of (g) portion of Needle Guard(G) is about 1.0mm above the tip of the Needle. Fix Needle Guard(G) to push Needle slightly. The clearance between Needle and Needle Guard is 0mm or up to 0.2mm.

When Needle(F) is adjusted, the right and left Needles can be also adjusted. However, check their condition.

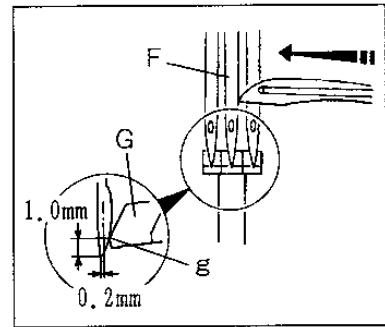

5-7 Adjustment of Upper Feed Roller(VF2502P)

When lowering Upper Feed Roller(H), the clearance between (H) and Roller Support(J) should be the same thickness as a fabric. To adjust it, loosen Nut(K) before turning Adjusting Screw(L).

When Presser Foot touches the surface of Stitch Plate, the clearance between the lower side of the slot of Lifter Connecting Plate and Screw(M) is 0.5mm. To adjust it, loosen Screw(N) of Upper Feed Roller Lifter(Right).

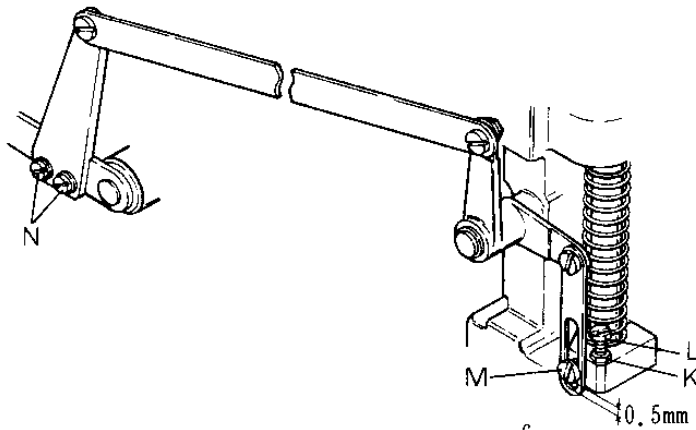
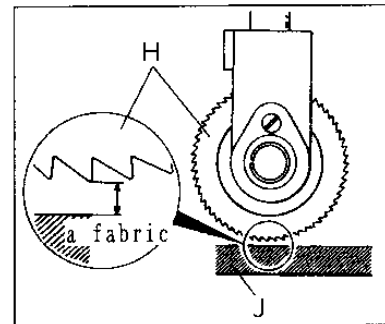

VF2502, VF2502P(1)

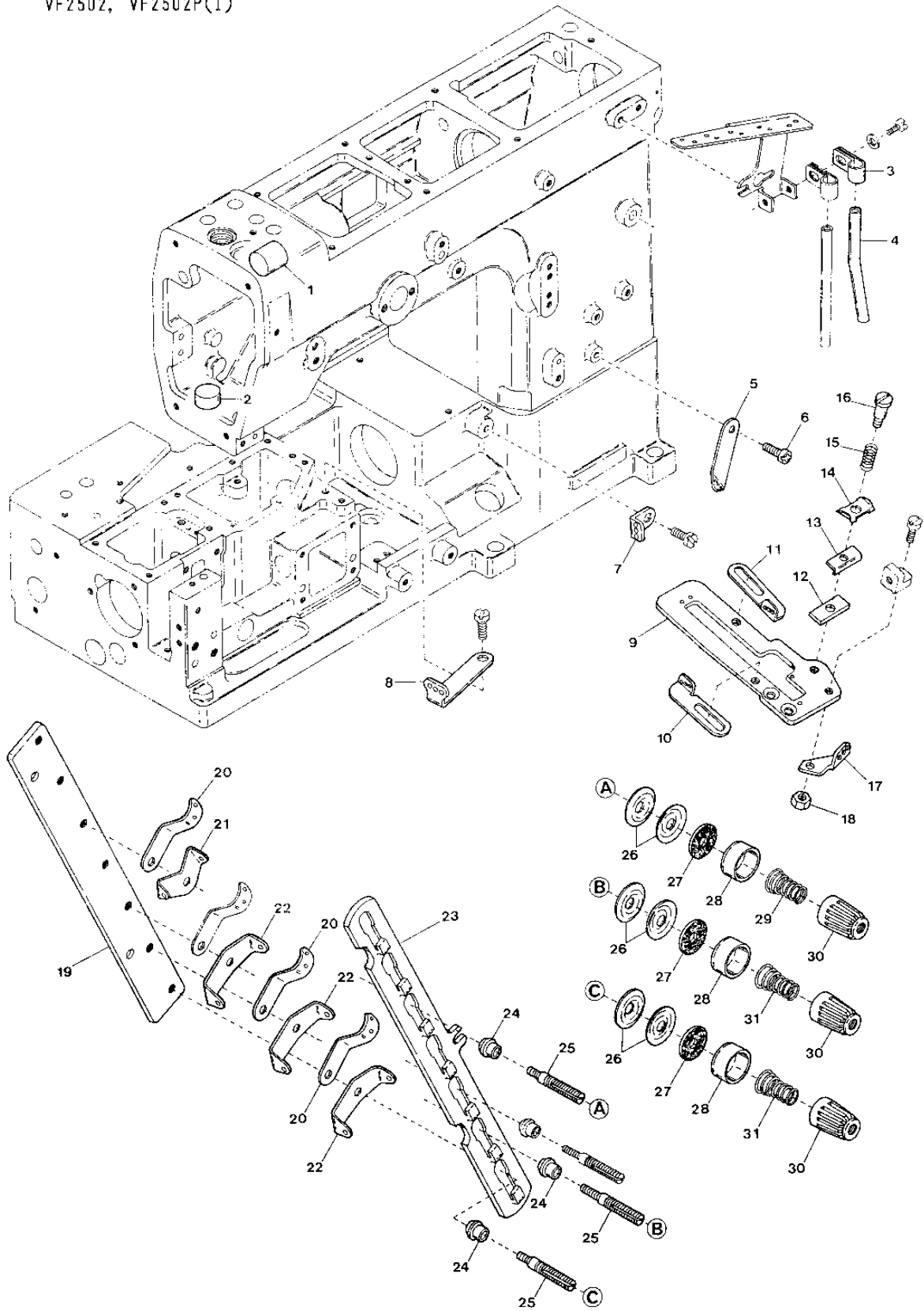

VF2502, 2502P EXCLUSIVE PARTS(1)

サブモデル専用部品(1)

Ref. No.	Parts No.	Description	品名	Amt. Req.
1	0094604	Seal Plug	詰栓	1
2	0063548	Seal Plug	詰栓	1
3	0093528	Thread Eyelet Pipe Stay	糸道パイプ支エ	1
4	0021735	Thread Eyelet Pipe(Long)	糸道パイプ(長)	1
5	0095916	Looper Thread Eyelet	ルーパー糸道	1
6	110013	Screw(M4-0.7×8)	止ネジ	1
7	3201156	Looper Thread Eyelet(Right)	ルーパー糸道(右)	1
8	3201157	Looper Thread Eyelet(Left)	ルーパー糸道(左)	1
9	3201152	Supporting Plate	カム糸道取付板	1
10	0095921	Thread Take-up Eyelet(Left)	調子カム糸道(左)	1
11	0095922	Thread Take-up Eyelet(Right)	調子カム糸道(右)	1
12	0095909	Supplementary Tension Holder	小調子台	1
13	0036175	Supplementary Tension Plate	小調子板	1
14	0032425	Supplementary Tension Disc	小調子皿	1
15	0090846	Looper Thread Retainer Spring	小調子バネ	1
16	270012	Screw(1/8-44×5)	止ネジ	1
17	3201153	Looper Thread Eyelet(Center)	ルーパー糸道(中)	1
18	000322	Nut	ナット	1
19	3201163	Tension Post Support	糸調子台	1
20	0090807	Thread Lead-in Guide	糸調子台糸道	3
21	0090856	Tension Disc Eyelet	糸調子皿糸道	1
22	0090857	Looper Thread Tension Disc Eyelet	下糸調子皿糸道	3
23	3201162	Tension Post Support	糸調子台	1
24	0090812	Tension Post Ferrule	糸調子棒糸摺レ	3
25	009835	Tension Post	糸調子棒	3
26	0031111	Tension Disc	糸調子皿	6
27	000177	Felt	フェルト	3
28	0090071	Thread Tension Spring Retainer	糸調子バネキャップ(下)	3
29	0090814	Needle Thread Tension Spring	針糸調子バネ	1
30	0093863	Thread Tension Spring Cap	糸調子バネキャップ(上)	3
31	0090847	Looper Thread Tension Spring	ルーパー糸調子バネ	2

VF2502, 2502P(2)

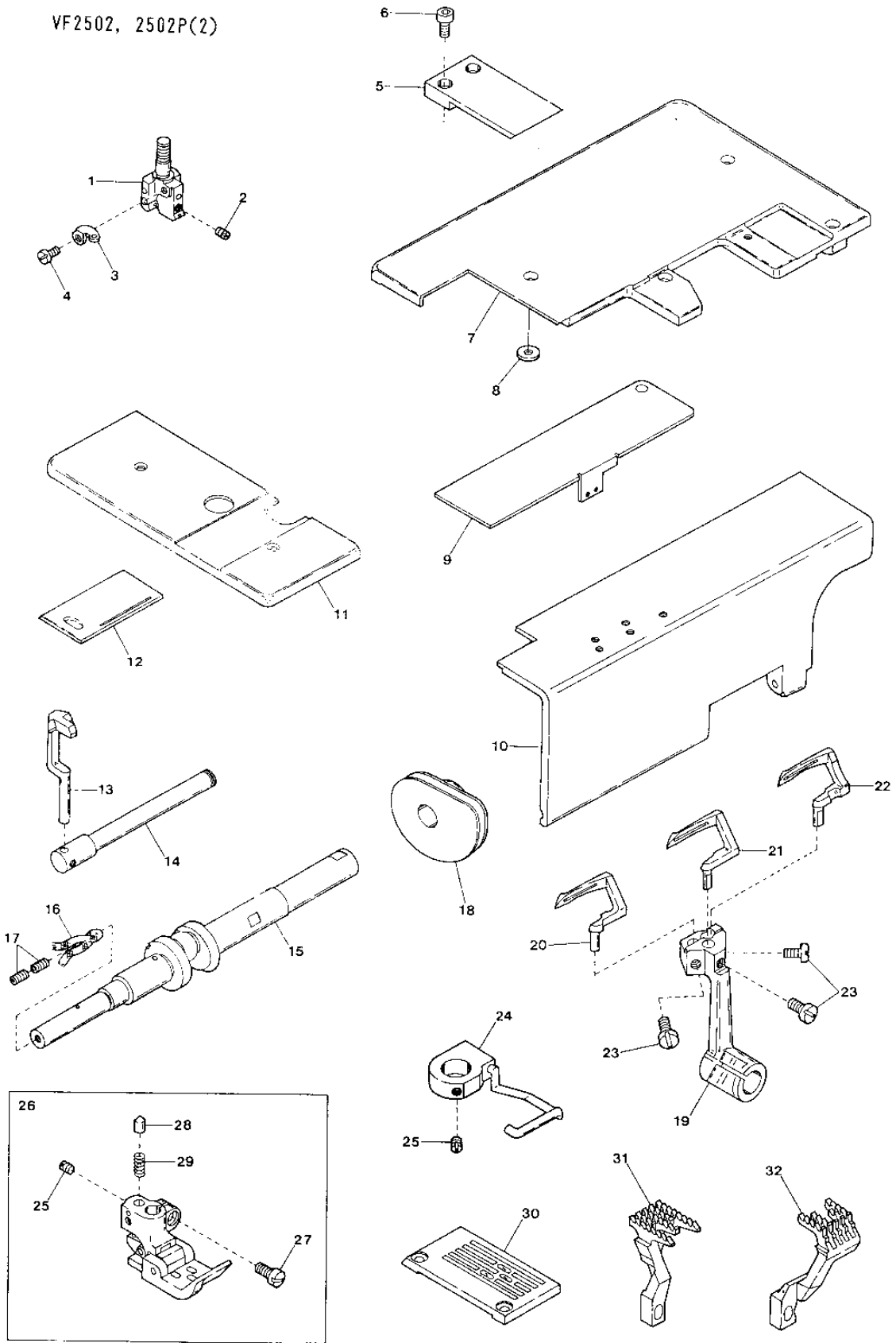

VF2502, 2502P EXCLUSIVE PARTS(2)

サブモデル専用部品(2)

Ref. No.	Parts No.	Description	品名	Amt. Req.
1	3209113	Needle Clamp(88)	針止メ	1
2	001892	Screw(1/8-44×2.9)	止ネジ	3
3	3201493	Needle Clamp Eyelet	針止メ糸道	1
4	001230	Screw(3/32-56×3.8)	止ネジ	3
5	3201491	Puller Support	プラー受ケ	1
6	009747	Screw(M4-0.7×10)	止ネジ	2
7	3201492	Cloth Plate(Large)	大カバー	1
8	300006	Washer	ワッシャ	1
9	3200035	Looper Thread Take-up Cover	カムカバー	1
10	3200034	Front Cover	前開キカバー	1
11	3201160	Cloth Plate(Small)	小カバー	1
12	0095936	Slide Cover	小カバー滑り板	1
13	3209203	Needle Guard	針受ケ	1
14	3201155	Needle Guard Driving Shaft	針受ケ軸	1
15	3201166	Lower Crankshaft	下軸クランク	1
16	310055	Oil Wick	油芯	1
17	160007	Screw(M6-1×6)	止ネジ	2
18	0094512	Looper Thread Taku-up	下糸調子カム	1
19	3201490	Looper Holder	ルーパ台	1
20	3209314	Looper(Left)	ルーパ(左)	1
21	3209313	Looper(Medium)	ルーパ(中)	1
22	0095931	Looper(Right)	ルーパ(右)	1
23	110057	Screw(M4-0.7×7)	止ネジ	3
24	3200253	Finger Guard Unit	フィンガガード(組)	1
25	001459	Screw(9/64-40×3)	止ネジ	3
26	3207013	Presser Foot, Complete Set(64)	押エ(組)	1
27	001186	Screw(9/64-40×7.8)	止ネジ	1
28	0037166	Presser Foot Pin	押エピン	1
29	0037164	Presser Foot Spring	押エバネ	1
30	3208063	Stitch Plate(64M)	針板	1
31	3209038	Main Feed Dog	後送り	1
32	3209039	Differential Feed Dog	前送り	1

VF2502P EXCLUSIVE PARTS(3)

サブモデル専用部品(3)

Ref.	Parts		Amt.	
No.	No.	Description	品名	
			Req.	
1	3100625	Upper Feed Roller Shaft Bracket	上ローラ軸ブラケット	1
2	120019	Screw(M6-1×18)	止ネジ	4
3	000779	Knock Pin	ノックピン	2
4	3100006	Seal Plug	詰栓	1
5	3100607	Roller Shaft Bushing(Right)	上ローラ軸ブッシュ(右)	1
6	3100604	Upper Feed Roller Shaft Lever	上ローラ軸腕	1
7	160007	Screw(M6-1×6)	止ネジ	2
8	0065398	Collar(14×22×10mm)	カラー	1
9	009604	Screw(11/64-40×5.5)	止ネジ	2
10	3100626	Roller Shaft Bushing(Left)	上ローラ軸ブッシュ(左)	1
11	0065395	Oil Seal	オイルシール	1
12	3100605	Upper Feed Roller Shaft	上ローラ軸	1
13	3100608	Upper Feed Roller Lever	上ローラレバー	1
14	120012	Screw(M6-1×20)	止ネジ	1
15	0065400	Upper Feed Roller Lever Rod	上ローラレバーロッド	1
16	001174	Screw(9/64-40×10.3)	止ネジ	2
17	0060109	Ball Stud	上ローラレバーロッド球	1
18	0065401	Upper Feed Roller Lever Pin	上ローラレバーピン	1
19	0065402	Upper Feed Roller Lever Rod Sleeve	レバーロッドスリーブ	1
20	000613	Washer	ワッシャ	1
21	000306	Nut	ナット	1
22	0032921	Upper Feed Roller Driving Rod Pin	上ローラロッドピン	1
23	160001	Screw(M4-0.7×4)	止ネジ	1
24	3100602	Upper Feed Roller Driving Rod	上ローラロッド	1
25	3100192	Retaining Ring	ストップリング	1
26	3100623	Roller Bearing	ニードルベアリング	1
27	3100603	Upper Feed Roller Regulator, C. Set	上ローラ調節器(組)	1
28	3100601	Upper Feed Roller Eccentric	上ローラエキセン	1
29	3100600	Upper Feed Roller Regulator	上ローラ調節器	1
30	160003	Screw(M5-0.8×5)	止ネジ	2
31	190007	Adjusting Screw(M5-0.8×6)	調節ネジ	1
32	120008	Screw(M4-0.7×8)	止ネジ	1
33	3101212	Upper Feed Roller Driving Rod, C. Set(2)	上ローラロッド(組2)	1

VF2502P(4)

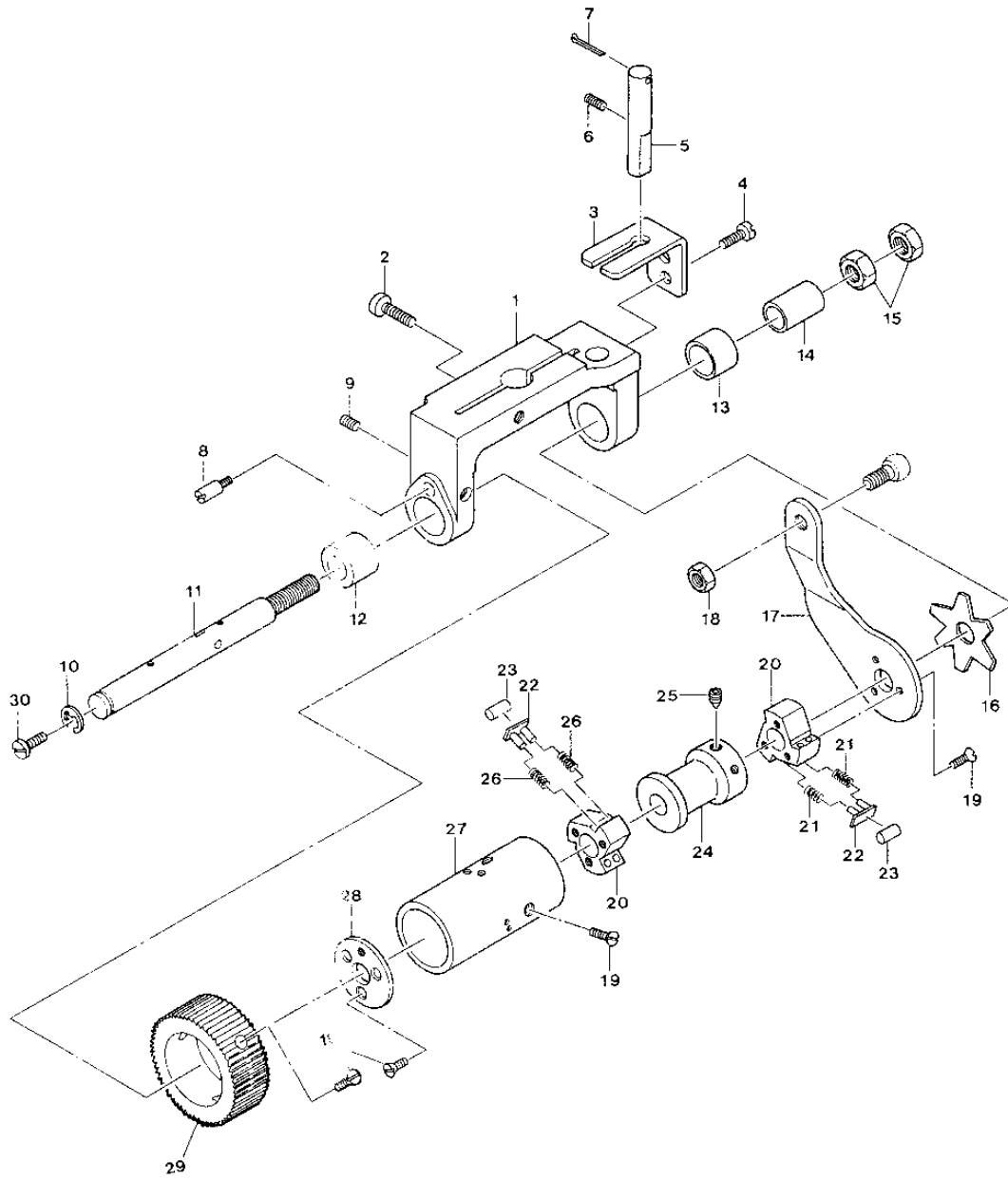

VF2502P EXCLUSIVE PARTS(4)

サブモデル専用部品(4)

Ref. No	Parts No	Description	品名	Amt. Req.
1	3300070	Upper Feed Roller Yoke	上ローラヨーク	1
2	120012	Screw(M6-1×20)	止ネジ	1
3	3300071	Upper Feed Roller Yoke Guide	上ローラヨークガイド	1
4	110009	Screw(M4-0.7×8)	止ネジ	2
5	3100613	Upper Feed Roller Yoke Pin	上ローラヨークピン	1
6	003662	Screw(M6-1×6)	止ネジ	1
7	0090620	Cotter Pin	割リピン	1
8	006270	Screw(9/64-40×0.5)	止ネジ	1
9	160001	Screw(M4-0.7×4)	止ネジ	2
10	0060056	Retaining Ring	ストップリング	1
11	3300072	Clutch Driving Shaft	クラッチ軸	1
12	3100616	Clutch Driving Shaft Bushing(Left)	クラッチ軸ブッシュ(左)	1
13	0065414	Clutch Driving Shaft Bushing(Right)	クラッチ軸ブッシュ(右)	1
14	0065421	Clutch Tension Sleeve	クラッチテンションスリーブ	1
15	000145	Adjusting Nut	調節ナット	2
16	0065420	Clutch Tension Spring	クラッチテンションバネ	1
17	3300074	Clutch Driving Lever	クラッチ板(右)	1
18	000306	Nut	ナット	1
19	007621	Screw(9/64-40×8.5)	止ネジ	12
20	0095061	Clutch	クラッチ	2
21	3010022	Clutch Spring(Thick)	クラッチバネ(太)	6
22	0095066	Clutch Spring Seat	クラッチバネ座	6
23	0065417	Clutch Roller	クラッチローラ	6
24	3300073	Clutch Spacer	クラッチスペーサ	1
25	160005	Screw(M6-1×8)	止ネジ	1
26	0095065	Clutch Spring(Thin)	クラッチバネ(細)	6
27	3300075	Clutch Sleeve	クラッチスリーブ	1
28	0065418	Clutch Check Plate	クラッチ板(左)	1
29	3201494	Upper Feed Roller(60 teeth)	上ローラ(60山)	1
30	110011	Screw(M5-0.8×10)	止ネジ	1

VF2502P EXCLUSIVE PARTS(5)

サブモデル専用部品(5)

Ref. No.	Parts No.	Description	品名	Amt. Req.
1	0065381	Upper Feed Roller Lifter(Right)	上ローラ揚ゲ(右)	1
2	004440	Screw(11/64-40×8.3)	止ネジ	2
3	000538	Washer	ワッシャ	3
4	000334	Nut	ナット	2
5	0034979	Flexible Wire Clamp Bushing	ワイヤ止メブッシュ	2
6	006075	Screw(11/64-40×6)	止ネジ	2
7	0067126	Lifter Connecting Plate	上ローラ揚ゲ連結板	1
8	0065374	Upper Feed Roller Lifter(Left)	上ローラ揚ゲ(左)	1
9	0065375	Upper Feed Roller Lifter Pin	上ローラ揚ゲピン	1
10	0095027	Retaining Ring	ストップリング	2
11	0065376	Lifter Connecting Plate	上ローラ吊り	1
12	006038	Screw(3/16-32×2.2)	止ネジ	2
13	0065407	Roller Press Bar Bracket	上ローラ押エ棒抱キ	1
14	005650	Screw(M5-0.8×14)	止ネジ	1
15	0065402	Lifting Lever Sleeve	上ローラレバースリーブ	1
16	006411	Screw(11/64-40×5.5)	止ネジ	1
17	000340	Lock Nut	ロックナット	1
18	009931	Stop Screw(11/64-40×26)	ストップネジ	1
19	3100614	Roller Press Spring	上ローラ押エバネ	1
20	3100610	Upper Feed Roller Bracket	上ローラブラケット	1
21	009753	Screw(M6-1×35)	止ネジ	2
22	000779	Knock Pin	ノックピン	2
23	0065405	Roller Press Bar Bushing(Upper)	上ローラ押エ棒ブッシュ(上)	1
24	160007	Screw(M6-1×6)	止ネジ	1
25	3100609	Roller Press Bar Bushing(Lower)	上ローラ押エ棒ブッシュ(下)	1
26	0065404	Upper Feed Roller Press Bar	上ローラ押エ棒	1
27	0034117	Retaining Ring	ストップリング	1
28	000690	Stop Pin	ストップピン	1
29	000613	Washer	ワッシャ	1
30	0067111	Upper Feed Roller Lifting Lever	手揚ゲ	1
31	000487	Corrugated Washer	波形ワッシャ	1
32	170008	Screw(M6-1×9)	止ネジ	1
33	3201495	Lifter Lever	押エ揚ゲレバー	1